

**THE AM MANUFACTURING CO.
SCALE - A - BAGEL
BAGEL DIVIDER / FORMER
SAB - 802
MAINTENANCE AND SAFETY MANUAL**

INCLUDING PARTS CATALOG

PROJECT No.: PRJ314

SERIAL No.: _____

MANUFACTURING SHIP DATE: _____



CAUTION:

DO NOT OPERATE, CLEAN OR SERVICE THIS MACHINE BEFORE YOU READ THIS MANUAL, AND ARE FAMILIAR WITH THE SAFETY INSTRUCTIONS IN THIS MANUAL AND THOSE ON THE LABELS ON THE MACHINE. KEEP THIS MANUAL AND OTHER MATERIALS DELIVERED WITH THE MACHINE, ACCESSIBLE TO THE OPERATORS FOR EASY REFERENCE DURING USE.

IF YOU SHOULD HAVE
ANY (?) QUESTIONS
ABOUT GUARDS OR
PLACEMENT CALL
(708) 841-0959.

THE ENTIRE CONTENTS OF THIS PUBLICATION ARE
COPYWRITTEN AND ALL RIGHTS ARE RESERVED.
REPRODUCTION IN WHOLE OR IN PART IS PROHIBITED
WITHOUT WRITTEN PERMISSION OF A.M. MFG. INC.



MANUFACTURING COMPANY

9200 CALUMET AVE. SUITE NW 07 MUNSTER, IN 46321
(219) 474-7272 (800) 342-6744 FAX: (219) 472-7271 www.ammfg.com

OWNER'S RESPONSIBILITY

NOTE:

THE PARTS AND EQUIPMENT DESCRIBED IN THIS MANUAL MAY BE COVERED BY ONE OR MORE U.S. AND FOREIGN PENDING PATENTS.



TO MAINTAIN MACHINE AND USER SAFETY, IT IS THE RESPONSIBILITY OF THE OWNER TO READ AND FOLLOW THESE INSTRUCTIONS AND TO ENSURE THAT ALL OPERATORS UNDERSTAND AND FOLLOW THESE AND OTHER SAFETY INSTRUCTIONS.

- FOLLOW ALL INSTALLATION INSTRUCTIONS.
- MAKE SURE INSTALLATION CONFORMS TO ALL APPLICABLE LOCAL, STATE, AND FEDERAL CODES, RULES AND REGULATIONS SUCH AS STATE AND FEDERAL OSHA REGULATIONS AND ELECTRICAL CODES.
- CAREFULLY CHECK THE UNIT FOR CORRECT INITIAL FUNCTION.
- READ AND FOLLOW THE SAFETY INSTRUCTIONS. KEEP THEM READILY AVAILABLE FOR MACHINE OPERATORS.
- MAKE CERTAIN ALL OPERATORS ARE PROPERLY TRAINED, KNOW HOW TO SAFELY AND CORRECTLY OPERATE THE UNIT AND ARE PROPERLY SUPERVISED.
- ALLOW UNIT OPERATION ONLY WITH ALL PARTS INCLUDING SAFETY EQUIPMENT, IN PLACE AND OPERATING SAFELY.
- CAREFULLY INSPECT THE UNIT ON A REGULAR BASIS AND PERFORM ALL MAINTENANCE AS REQUIRED.
- SERVICE AND MAINTAIN THE UNIT ONLY WITH AUTHORIZED OR APPROVED REPLACEMENT PARTS.

KEEP ALL INSTRUCTIONS PERMANENTLY WITH THE UNIT. KEEP ALL DECALS AND WARNING LABELS ON THE UNIT CLEAN AND VISIBLE.

TABLE OF CONTENTS

DESCRIPTION (DOUGH DIVIDER)	PAGE	DESCRIPTION (BAGE FORMER)	PAGE
COVER	1	BLANK PAGE	44
OWNERS RESPONSIBILITIES	2	INTRODUCTION & SPECIFICATIONS & INSTALLATION	45
TABLE OF CONTENTS	3	LOCATION OF WARNING LABELS	46 ~ 47
INTRODUCTION & SPECIFICATIONS & INSTALLATION	4	OPERATING INSTRUCTIONS	48
SAFETY SIGNAL WORDS	5	GENERAL MAINTENANCE	49
LOCATION OF WARNING LABELS	6 ~ 7	ASSEMBLY INSTRUCTIONS	50
SAFETY RULES	8	FORMING BELT TIGHTENING PROCEDURES	51
OPERATING INSTRUCTIONS	9	CLEANING PROCEDURES	52
CLEANING PROCEDURES	10 ~ 12	BLANK PAGE	53
GENERAL MAINTENANCE	13 ~ 14	IDLER ROLLER ASSEMBLY	54 ~ 55
BLANK PAGE	15	FORMING MANDREL ASSEMBLY	56 ~ 57
CABINET ASSEMBLY	16 ~ 17	DRIVE ROLLER ASSEMBLY	58 ~ 59
HOPPER COVER (STANDARD)	18 ~ 19	TABLE ASSEMBLY	60 ~ 61
HOPPER COVER (EXTENDED)	20 ~ 21	CABINET ASSEMBLY	62 ~ 63
DIVIDER SLIDE GUARD	22~23	ELECTRICAL LAYOUT	64 ~ 65
CYLINDER & DRIVER ASSEMBLY	24 ~ 27	ORDERING REPLACEMENT PARTS	66
MEASURING CUP & DIVIDER SLIDE ASSEMBLY	28 ~ 30	NOTES	67
BLANK PAGE	31		
PISTON-CONNECTING ROD & SPRING ASSEMBLY	32 ~ 33		
SMALL CONVEYOR & DRIVE ASSEMBLY	34 ~ 35		
OILING SYSTEM ASSEMBLY	36		
BLANK PAGE	37		
ELECTRICAL CONTROL PANEL	38 ~ 40		
ELECTRICAL SCHEMATICS	41 ~ 42		
TROUBLESHOOTING	43		

IMPORTANT:

A.M. MANUFACTURING Co. RESERVES THE RIGHT TO MAKE CHANGES IN DESIGN, SPECIFICATIONS OR MANUFACTURING. TO IMPROVE THEIR PRODUCTS WITHOUT NOTICE AND WITHOUT OBLIGATION TO CHANGE OR IMPROVE PREVIOUSLY BUILT PRODUCTS INCLUDING MANUALS AND CATALOGS.

ONLY USE FACTORY SUPPLIED REPLACEMENT PARTS TO MAINTAIN MACHINE SAFETY, PERFORMANCE AND SANITARY CONDITIONS. USE OF NON-APPROVED PARTS MAY VOID MANUFACTURERS WARRANTY.

KNOW YOUR UNIT. COMPARE DIAGRAMS IN THIS MANUAL WITH THE UNIT BEFORE STARTING SERVICE, TO OBTAIN MAXIMUM SAFETY AND PERFORMANCE.

TO ORDER REPLACEMENT PARTS:
TURN TO PAGE 66 OF THIS MANUAL



WARNING:

THIS MANUAL CONTAINS CRITICAL SAFETY INSTRUCTIONS. READ AND FOLLOW THEM CAREFULLY. FAILURE TO FOLLOW WARNING AND INSTRUCTIONS MAY LEAD TO SERIOUS PERSONAL INJURY. THE OWNER IS RESPONSIBLE FOR MAINTAINING THE UNIT, ITS INSTRUCTIONS AND DECALS FOR OPERATION REFERENCE. FOR ADDITIONAL COPIES CONTACT A.M. MANUFACTURING: (800)342-6744

OPERATIONS AND SAFETY MANUAL

INCLUDING PARTS CATALOG

READ AND FAMILIARIZE YOURSELF WITH THIS MANUAL BEFORE OPERATING THIS MACHINE FOLLOW INSTRUCTIONS DURING USE

INTRODUCTION

THE SCALE A BAGEL MODEL DOUGH DIVIDER AND BAGEL FORMER IS DESIGNED TO GIVE YOU OPTIMUM TROUBLE FREE TIME SAVING SERVICE. IT IS DESIGNED TO SCALE FROM (1) TO (5-1/2) oz. BAGELS DEPENDING ON DOUGH FORMULATION AND MANDREL SIZE, WITH A SPEED RANGE OF 210 DOZEN PER HOUR.

NEW AND CURRENT EMPLOYEES CAN BE TAUGHT TO OPERATE THIS MACHINE EFFICIENTLY AND SAFELY IN A SHOR PERIOD OF TIME. WE URGE YOU TO STUDY THIS OPERATIONS AND SAFETY MANUAL FOR FULL BENEFITS.



CAUTION:

ALL OPERATORS MUST BE FULLY TRAINED AND INSTRUCTED IN SAFETY PROCEDURES BEFORE BEGINNING PRODUCTION.

SPECIFICATIONS

HOPPER CAPACITY	140 lbs.
PRODUCTION RATE	210 DOZEN PER HOUR
HEIGHT	64"
LENGTH	142"
WIDTH	34"
SHIPPING WEIGHT	490 lbs.
DIVIDER MOTOR	3 PHASE, 2 H.P. MOTOR (OPTIONAL) SINGLE PHASE, 1-1/2 H.P. DOUBLE SHEAVE BELT DRIVE
SMALL CONVEYOR FORMER	1 PHASE, 1/6 H.P. MOTOR 3 PHASE, 1 H.P. MOTOR (OPTIONAL) SINGLE PHASE, 3/4 H.P.
RECIPROCAL MOTION / MECHANICAL DIVIDER / AUTOMATIC SPRING PRESSURE, SELF ADJUSTABLE	
EXTRA DIVIDER CUPS AVAILABLE AS OPTIONAL EQUIPMENT. NO. 2 DIVIDING CUP 2 TO 4 OZ. NO. 3 DIVIDING CUP 4 TO 10 OZ. NO. 5 DIVIDING CUP 10 TO 32 OZ.	
VOLTAGES: 3 PHASE / 208 - 230 VOLTS / 12.4 AMPS (OPTIONAL) SINGLE PHASE, 208 – 230 VOLT	

INSTALLATION INSTRUCTIONS

LOCATION:

SELECT LOCATION CAREFULLY. THE AREA SHOULD PROVIDE THE OPERATOR WITH ENOUGH SPACE TO USE THE EQUIPMENT IN A SAFE MANNER. THE FLOOR AREA SELECTED SHOULD BE EASY TO CLEAN AND SHOULD BE FREE OF OIL, GREASE, ETC. AVOID AREAS WHERE BYSTANDERS AND CUSTOMERS MAY BE PRESENT.



CAUTION:

PROPER UNIT INSTALLATION IS NECESSARY FOR SAFE AND EFFICIENT OPERATION. PROPER INSTALLATION ALSO HELPS PROTECT THE UNIT FROM DAMAGE AND MAKES SERVICE EASIER.

SAFETY SIGNAL WORDS

THIS MACHINE IS DESIGNED TO PROVIDE FOR SAFE OPERATION IF NORMAL OPERATING PROCEDURES AND SAFETY MESSAGES LOCATED ON THE MACHINE AND IN THIS MANUAL ARE FOLLOWED.



THIS IS A SAFETY ALERT SYMBOL. YOU WILL FIND IT ON VARIOUS SAFETY LABELS ON THE MACHINE AND IT WILL ALSO APPEAR IN THIS MANUAL WHEREVER SAFETY MESSAGES ARE GIVEN.

GET FAMILIAR WITH SIGNAL WORDS:

CAUTION, WARNING & DANGER

CAUTION:

INDICATES A POTENTIALLY HAZARDOUS SITUATION WHICH, IF NOT AVOIDED, MAY RESULT IN MINOR OR MODERATE INJURY. IT MAY ALSO BE USED TO ALERT AGAINST UNSAFE PRACTICES.

WARNING:

INDICATES A POTENTIALLY HAZARDOUS SITUATION WHICH, IF NOT AVOIDED, COULD RESULT IN DEATH OR SERIOUS INJURY.

DANGER:

INDICATES AN IMMINENTLY HAZARDOUS SITUATION WHICH, IF NOT AVOIDED, WILL RESULT IN DEATH OR SERIOUS INJURY. THIS SIGNAL WORD IS TO BE LIMITED TO THE MOST EXTREME SITUATIONS.

NOTE:

A NOTE PROVIDES KEY INFORMATION TO MAKE PROCEDURES EASIER AND CLEARER.

TYPICAL WARNING LABEL LOCATIONS

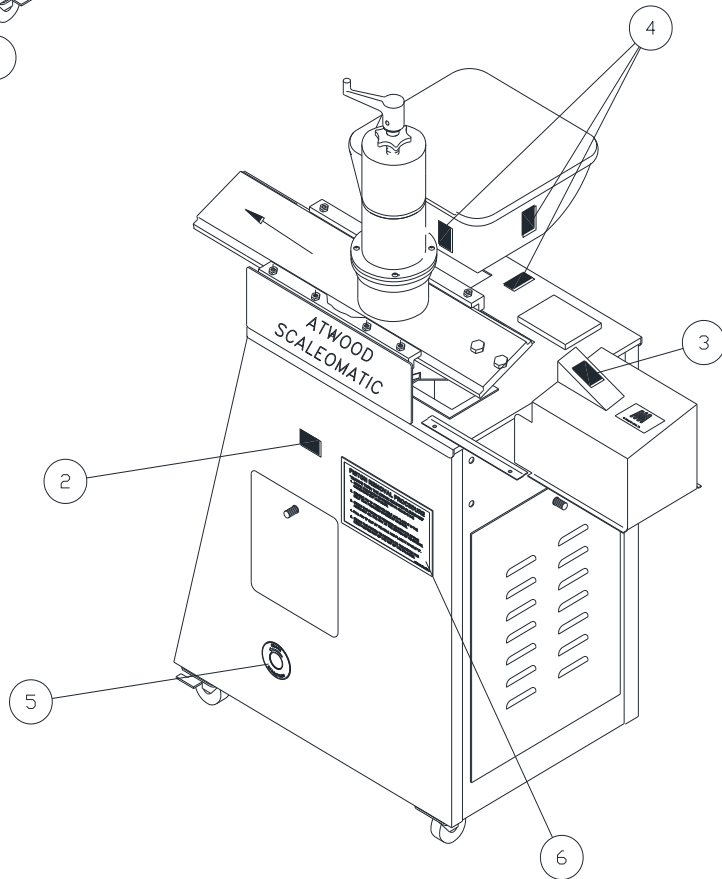
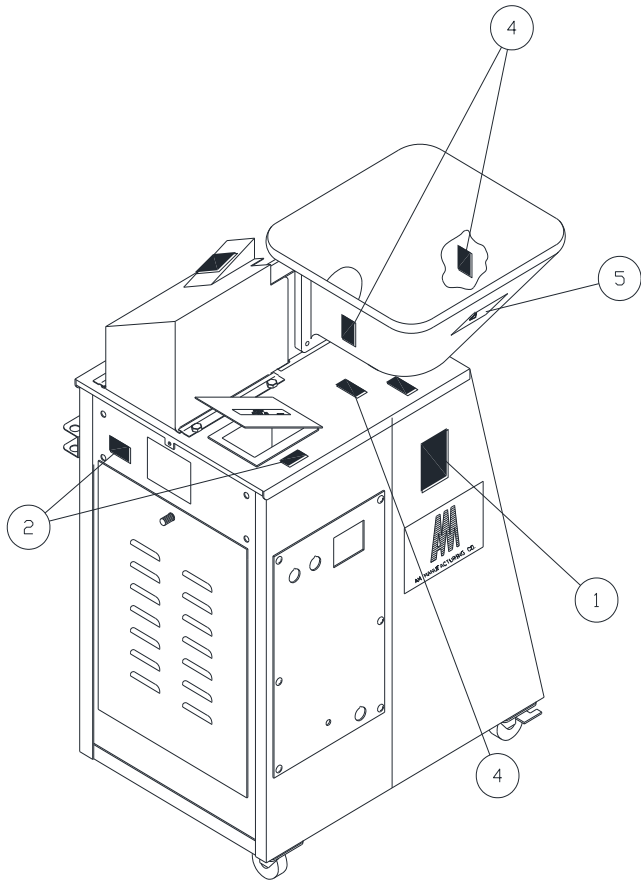

WARNING LABELS

TYPICALLY FOUND ON THE SCALE-O-MATIC SAB-802

1 PART NO. AM MFG. # 21

IMPORTANT SAFETY INFORMATION © 1992 A.M. MFG. # 21

- DO NOT OPERATE THIS MACHINE BEFORE YOU HAVE READ AND UNDERSTAND THE OPERATIONS AND SAFETY MANUAL.
- NEVER LEAVE THIS MACHINE RUNNING UNATTENDED.
- NEVER OPERATE THIS MACHINE IF SAFETY GUARDS ARE NOT IN PLACE.
- NEVER REMOVE ANY SAFETY GUARDS AND NEVER MAKE ANY OTHER SAFETY EQUIPMENT INOPERATIVE.
- NEVER OPERATE THIS MACHINE IF YOU HAVE NOT BEEN TRAINED.
- NEVER OPERATE THIS MACHINE IF YOU ARE TIRED, ILL, OR IF YOU ARE ON MEDICATION THAT MAKES YOU TIRED, OR IF YOU ARE UNDER THE INFLUENCE OF ALCOHOL OR DRUGS.
- WEAR TIGHT FITTING CLOTHES AND MAKE SURE THAT LONG HAIR AND JEWELRY OR OTHER LOOSE PERSONAL ITEMS DO NOT GET CAUGHT IN THE MACHINE.
- MAKE SURE YOU CAN EASILY REACH THE CONTROLS.
- ALWAYS DISCONNECT THE MAIN ELECTRICAL POWER SOURCE BEFORE YOU CLEAN, MAINTAIN, OR SERVICE THIS MACHINE.
- IF YOU HAVE ANY QUESTIONS ABOUT SAFETY, TALK TO YOUR SUPERVISOR OR CALL

A. M. MANUFACTURING
TOLL FREE 1-(800)-342-6744

MAIN FRAME (RIGHT SIDE OF CONTROL PANEL)

2 PART NO. AM MFG. # 10ASF

DANGER

HAZARDOUS VOLTAGE
WILL SHOCK, BURN OR CAUSE DEATH

DISCONNECT ALL ELECTRICAL POWER BEFORE REMOVING PROTECTIVE SHIELDS OR TOUCHING ELECTRICAL EQUIPMENT WHILE SERVICING OR CLEANING THIS MACHINE.....

TEVENION DANGEREUSE. CAUSERA UNE ELECTROCUTION, UNE BRULURE OU LA MORT.

COUPER TOUT COURANT ELECTRIQUE AVANT D'ENLEVER LES ECRANS DE PROTECTION OU DE TOUCHER L'EQUIPEMENT ELECTRIQUE PENDANT L'ENTRETIEN OU LE NETTOYAGE DE CETTE MACHINE.....

© 2010 AM MFG. #10ASF

- REAR PANEL OF DIVIDER CABINET
- CABINET (PISTON ENTRY SIDE)
- TOP COVER, ELECTRICAL BOX SIDE NEXT TO OIL PUMP BOX.

3 PART NO. AM MFG. # 11 & #11SF

WARNING

ALL GUARDS AND SAFETY SHIELDS MUST BE IN PLACE BEFORE STARTING MACHINE. NEVER OPERATE THIS MACHINE WITHOUT SAFETY SHIELDS IN PLACE. DO NOT CHANGE THIS MACHINE IN ANY WAY TO INTERFERE WITH OR ELIMINATE THESE ESSENTIAL SAFETY FEATURES.

© 1992 AM MFG. #11

- ROCKER ARM COVER

4 PART NO. AM MFG. # 27SF

DANGER

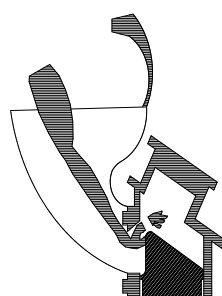

1993 AM MFG. #27

MOVING PISTON WILL CUT OFF FINGERS OR CAUSE SERIOUS INJURIES.

DO NOT PLACE HANDS IN HOPPER WHILE MACHINE IS RUNNING.

? ABOUT GUARDS AND GUARDING CALL (708-841-0959)

6 PART NO. AM MFG. # 203S

PISTON REMOVAL PROCEDURE

"ALWAYS TURN THE CRANK COUNTER CLOCKWISE"

- CRANK THE PISTON TO POSITION #1: REMOVE THE MEASURING CUP AND SLIDE.
- REMOVE PIN "A" FROM ITS HOLE AND PLACE IT IN THE BOLT TRAY PROVIDED ON SIDE OF MACHINE.
- CRANK THE PISTON TO POSITION #2 WITH THE SPRING ASSEMBLY ALL THE WAY AT THE BOTTOM OF ITS STROKE.
- PULL PIN "B" OUT OF ITS HOLE AND PLACE IT IN HOLE "C".
- CRANK THE PISTON TO POSITION #3: THE PISTON HAS BEEN PUSHED OUT OF THE TOP OF THE CYLINDER.

© 2004 A.M. MFG. 203S

-LEFT SIDE OF CABINET

5 PART NO. AM MFG. # 202S

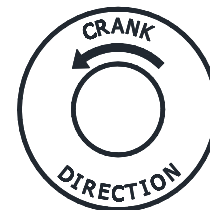

- LEFT SIDE OF CABINET

NOTE:

MACHINE DESIGN AND SPECIFICATIONS MAY VARY. ACTUAL LABEL DESIGN AND PLACEMENT SUBJECT TO CHANGE WITHOUT NOTICE AND MAY VARY FROM THIS ILLUSTRATION.



CAUTION:

IF ANY SAFETY LABELS ARE MISSING, THEY MUST BE REPLACED! CONTACT YOUR DEALER OR A.M. MFG. FOR REPLACEMENT.

SAFETY RULES



IMPORTANT:

READ AND FOLLOW THESE SAFETY RULES. THEY ARE FOR YOUR PROTECTION AND THE PROTECTION OF THOSE WORKING WITH YOU.

- DO NOT OPERATE THIS MACHINE BEFORE YOU READ AND UNDERSTAND THE OPERATIONS AND SAFETY MANUAL.
- FOLLOW ALL INSTRUCTIONS DURING USE OF THIS MACHINE.
- LEAVE ALL GUARDS IN PLACE. INSTALL ALL GUARDS IF THEY WERE REMOVED FOR CLEANING, MAINTENANCE, REPAIR OR OTHER REASONS.
- NEVER OPERATE THE MACHINE IF YOU HAVE NOT BEEN TRAINED TO OPERATE THE MACHINE PROPERLY.
- NEVER OPERATE THE MACHINE IF YOU ARE TIRED, ILL, ON MEDICATION, OR UNDER THE INFLUENCE OF ALCOHOL OR DRUGS.
- WEAR TIGHT FITTING CLOTHES. MAKE SURE THAT LONG HAIR, JEWELRY, OR LOOSE PERSONAL ITEMS ARE SECURED SO THEY CANNOT GET CAUGHT IN THE MACHINE. THIS CAN LEAD TO SERIOUS INJURIES.
- MAKE SURE YOU CAN EASILY REACH ALL CONTROLS. IF NOT, A STABLE AND SAFE ELEVATED PLATFORM OR OTHER WORK-AID MUST BE PROVIDED.
- ALWAYS DISCONNECT THE MAIN ELECTRICAL POWER SOURCE BEFORE CLEANING, IF MAINTENANCE OR SERVICE IS PERFORMED, OR IF THE MACHINE IS OUT OF SERVICE.
- NEVER CLEAN BAGEL FORMING BELT ON MACHINE, ALWAYS REMOVE BELT FROM MACHINE TO CLEAN OR SERVICE (WHEN APPLICABLE).
- NEVER LEAVE THIS MACHINE RUNNING UNATTENDED.
- GUARDS ARE INTERLOCKED; MACHINE WILL NOT OPERATE WITHOUT GUARDS IN PLACE.

IMPORTANT:

IF YOU HAVE ANY QUESTIONS ABOUT THESE SAFETY RULES, SEE YOUR SUPERVISOR OR CALL A.M. MANUFACTURING Co. TOLL FREE: (800)342-6744.

OPERATING INSTRUCTIONS



WARNING:

UNIT MUST BE PROPERLY OPERATED AND MAINTAINED TO PREVENT MACHINE DAMAGE OR PERSONAL INJURY. REVIEW INSTRUCTIONS WITH ALL EMPLOYEES BEFORE USE.



CAUTION:

BEFORE BEGINNING START - UP, READ ALL INSTRUCTIONS AND FAMILIARIZE YOURSELF WITH THE LOCATIONS OF ALL CONTROLS. KNOW HOW TO SHUT DOWN THE UNIT IMMEDIATELY IN CASE OF TROUBLE. MAKE CERTAIN ALL PERSONNEL NOT INVOLVED IN THE START - UP ARE SAFELY AWAY FROM THE MACHINE BEFORE ANY SYSTEMS ARE STARTED...

I. PRELIMINARY START-UP PROCEDURE

- A. REMOVE PACKING, PACKING SLIPS, DOCUMENTS AND OTHER OBSTRUCTIONS FROM HOPPER.
- B. PLUG POWER CORD INTO PROPER RECEPTACLE.
- C. PUSH DIVIDER START BUTTON (LOACATED ON FORMER)
- D. LOOK THRU SMALL INSPECTION TO CHECK GEAR ROTATION. LARGE GEAR SHOULD BE TURNING (C.W.) CLOCK-WISE
- E. IF THE GEAR IS TURNING IN THE (C.C.W.) COUNTER- CLOCK WISE DIRECTION, CONSULT A PROPERLY TRAINED ELECTRICIAN.
- F. IF ROTATION IS CORRECT, YOU ARE READY TO CONTINUE ON WITH THESE PROCEDURES.
- G. CHECK POWER SUPPLY TO SMALL CONVEYOR BY PUSHING FORMER START BUTTON (LOCATED ON FORMER). THE DROP CONVEYOR BELT SHOULD BE RUNNING FORWARD, TWARDS THE BAGEL FORMER.
- H. IF DROP CONVEYOR DOES NOT RUN CONSULT A PROPERLY TRAINED ELECTRICIAN.

II. OPERATION OF DIVIDER



- A. FILL THE OIL RESERVOIR WITH LIGHT WEIGHT MINERAL OIL.
- B. WITH THE SQUIRT BOTTLE SUPPLIED, APPLY A SMALL AMOUNT OF MINERAL OIL TO THE INSIDE SIDES OF THE DOUGH HOPPER.
- C. OPEN THE VALVE LOCATED ON THE TOP GIB BAR APPROXIMATELY 1/8 OF A TURN.
- D. REMOVE BACK CABINET DOOR.
- E. OPEN THE CYLINDER VALVE APPROXIMATELY 1/8 OF A TURN. THIS VALVE IS LOCATED ON THE OIL PUMP INSIDE THE REAR DOOR.
- F. REINSTALL THE BACK CABINET DOOR.
- G. FILL THE HOPPER WITH DOUGH
- H. SET PADDLE ON TOP OF DOUGH
- I. PRESS DIVIDER START BUTTON. (LOCATED ON BAGEL FORMER)
- J. HOPPER SHOULD BE OILED EVERYTIME YOU PLACE NEW DOUGH IN IT.

III. DIVIDING THE DOUGH

- A. DOUGH IS PORTIONED IN THE CUP LOCATED ON THE DIVIDER SLIDE.
- B. TO ADJUST THE WEIGHT, STOP MACHINE.
- C. BY TURNING THE HANDLE IN A COUNTER CLOCKWISE MOTION, THE DOUGH WEIGHT WILL INCREASE. THE DOWN (CLOCKWISE) MOTION DECREASES THE DOUGH WEIGHT.
- D. FIND YOUR DESIRED DOUGH WEIGHT BY WEIGHING THE DOUGH PIECE.

IV. OPERATING THE FORMER

- A. FILL DOUGH IS PORTIONED IN THE CUP LOCATED ON THE DIVIDER SLIDE.
- B. IF FURTHER ADJUSTMENTS ARE NEEDED THEY CAN BE MADE AS FOLLOWS.

- 1  **STOP** THE MACHINE
- 2 IF BAGELS ARE SMALLER ON THE BOTTOM THAN THE TOP, YOU NEED TO RAISE THE MANDREL BAR (BFM23/BFM42) UP. THIS IS DONE BY TURNING THE ADJUSTMENT SCREW (BFM12)*(C.W.), OR (C.C.W.), IF THE BAGELS ARE SMALLER ON THE TOP.
- 3 RESTART THE MACHINE.
- 4 IF BAGELS ARE SMALLER ON THE RIGHT SIDE, THAN THE LEFT, YOU NEED TO ADJUST THE HORIZONTAL ADJUSTMENT BLOCKS (BFM4).
- 5  **STOP** THE MACHINE
- 6 LOOSEN THE FOUR SCREWS (BFM5) HOLDING THE ADJUSTMENT BLOCKS (BFM4) DOWN. MOVE THE ADJUSTMENT BLOCKS (BFM4) TO THE LEFT SIDE.
- 7 REVERSE THIS STEP IF BAGELS ARE SMALLER ON THE OPPOSITE SIDE.
- 8 RESTART MACHINE.
- 9 ONCE YOU HAVE ACHIEVED THIS, ADJUST THE LOCKING STAR KNOB (529MS-2D) TO THE TOP OF THE MEASURING CUP TO KEEP SCALING ACCURATE.

CLEANING PROCEDURES

THESE PROCEDURES ARE VERY IMPORTANT TO MAINTAIN PRODUCT QUALITY AND MACHINE PERFORMANCE.

ALL A.M. MANUFACTURING MACHINES ARE TESTED WITH DOUGH DURING THE IN-HOUSE RUN-IN AND QUALITY AUDIT PROCEDURE. ALTHOUGH THE MACHINE HAS BEEN CLEANED, SOME EVIDENCE OF DOUGH ON AND IN THE MACHINE MAY BE DETECTED. THIS IS NORMAL. ALL PARTS IN CONTACT WITH DOUGH SHOULD BE WASHED THOROUGHLY AFTER USE, USING A MILD SOAP AND WATER SOLUTION. DISASSEMBLY OF THIS MACHINE FOR CLEANING IS OUTLINED BELOW AND ILLUSTRATED FOR YOUR CONVENIENCE.

I. DIVIDER



DANGER: SHUT OFF ALL ELECTRICAL POWER.

- A.
- B.
- C.
- D.
- E.
- F.
- G.
- H.
- I.
- J.
- K.
- L.



PRACTICE SAFETY FIRST:

ALWAYS DISCONNECT ELECTRICAL SERVICE WHEN CLEANING OR MAINTAINING THIS MACHINE, THUS AVOIDING CHANCE OF SERIOUS INJURIES. MACHINES ARE NOT DANGEROUS IF COMMON SENSE IS APPLIED AND THE INSTRUCTIONS ARE CAREFULLY FOLLOWED. THINK AND PRACTICE SAFETY FIRST.

GUIDE TO CLEANING



DANGER:

ALWAYS DISCONNECT ELECTRICAL SERVICE WHEN CLEANING, MAINTAINING OR REPAIRING THIS MACHINE...

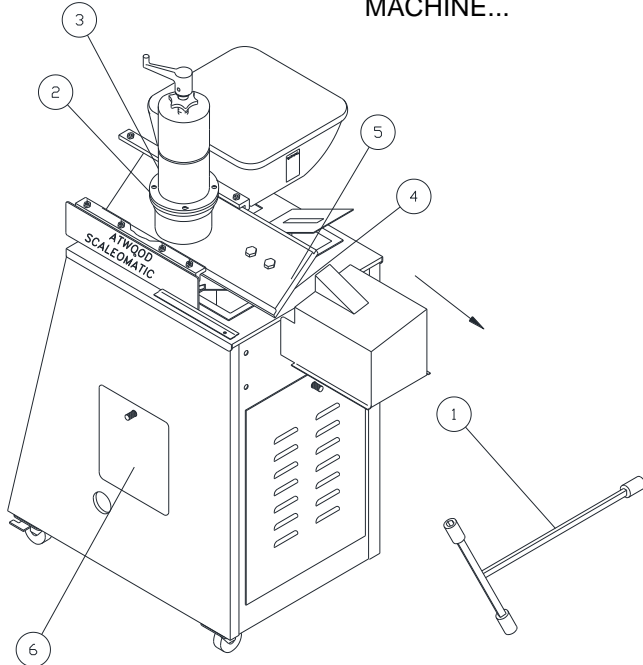

FIGURE 1

STEP 1

USING AN ALLEN WRENCH, LOOSEN SOCKET HEAD SCREWS (2) AND LIFT OFF DIVIDER PLUNGER (MEASURING CUP) (3). WHEN A #2 OR #3 MEASURING CUP IS EMPLOYED ON DIVIDER, THE DIVIDER CYLINDER MUST ALSO BE REMOVED FROM SLIDE FOR CLEANING.

STEP 2

LOOSEN EIGHT HEX HEAD BOLTS AT TOP OF GIB BARS. USING WRENCH (1) REMOVE TWO HEX HEAD SCREWS (4) AND PUSH DIVIDER SLIDE (5) REARWARD TO EXPOSE CYLINDER OPENING.

STEP 3

REMOVE CABINET DOOR (6).

STEP 4

WITH CYLINDER OPENING EXPOSED, REMOVE SEAL SCRAPER RING (7) AND RUBBER "O" RING (8). CLEAN ALL EXPOSED SURFACES INCLUDING "O" RING GROOVE AND DIVIDING SLIDE OF ACCUMULATED DOUGH, OIL, ETC. WIPE EXCESS DOUGH FROM TOP AND INTERIOR OF CYLINDER.

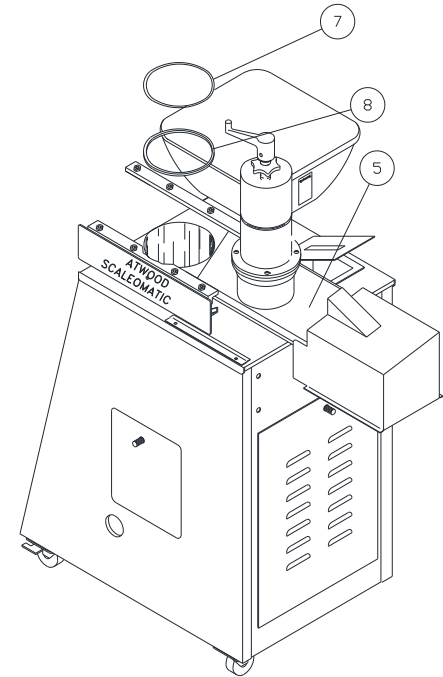

FIGURE 2

SCALE - O - MATIC NAME PLATE

THIS PLATE HAS A 2-CHANNEL GROOVE THAT CATCHES EXCESS OIL AND DRAINS INTO DRIP PAN AT THE BOTTOM OF THE MACHINE. THIS PLATE SHOULD BE REMOVED BY LOOSENING AND REMOVING A SMALL ALLEN SCREW IN THE CENTER OF THE PLATE. CLEAN PLATE, AND CHECK PLASTIC DRAIN LINE TO SEE THAT IT IS CLEAN AND FREE OF ANY SEDIMENT SO OIL CAN DRAIN PROPERLY. DRIP PAN AT BOTTOM OF MACHINE SHOULD BE EMPTIED EVERY DAY.

STEP 5

LOOSEN SOCKET SCREWS (9) ENOUGH TO SLIDE PIN LOCK BRACKET (10) EXPOSING LOCK PIN (11). REMOVE PIN (11).

STEP 6

INSERT CRANK HANDLE (12) THROUGH HOLE IN CABINET AND ENGAGE WITH PINION SHAFT. CRANK ONE COMPLETE TURN COUNTER CLOCK-WISE THUS EXTENDING PISTON ROD UNTIL HOLE (14) IS IN LINE WITH UPPER HOLE IN ROD (13).

STEP 7

PLACE PIN (11) INTO HOLE (14) TEMPORARILY. NOW REMOVE PIN (15), CONTINUE TO CRANK UNTIL PISTON (16) EMERGES FROM THE TOP OF THE CYLINDER. LIFT OUT CAREFULLY BY HAND. THOROUGHLY CLEAN PISTON AND CYLINDER TO REMOVE ALL ACCUMULATED DOUGH WITH A MILD SOAP AND WATER SOLUTION. DRY THOROUGHLY AND COAT ALL SURFACES WITH A LIGHT COATING OF DIVIDER OIL. TO REASSEMBLE, REVERSE STEPS 1 THROUGH 7.

WHEN CLEANING OR ADJUSTING PISTON, DO NOT OVER TIGHTEN ADJUSTING NUTS. THIS WILL OVER SPREAD YOUR PLASTIC PISTON RING AND WILL CAUSE EXCESSIVE WEAR, AND IT WILL ALSO BE HARD TO REPLACE PISTON BACK INTO THE CYLINDER. THIS COULD RESULT IN THE CUTTING OF YOUR PISTON RING WHICH WOULD DESTROY YOUR PISTON RING.

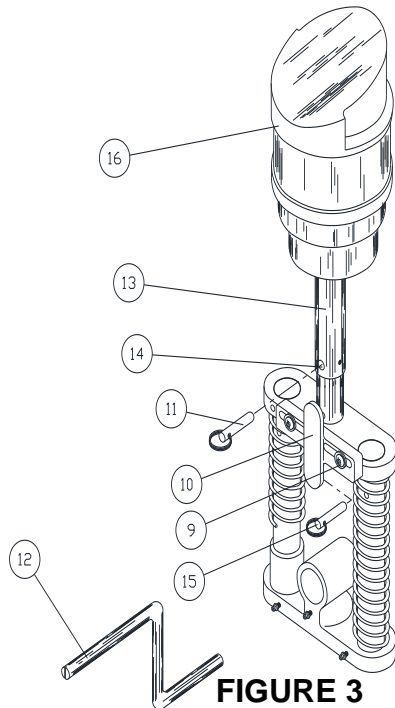

FIGURE 3

IMPORTANT:

WHEN RE-ASSEMBLING, DO NOT OVER TIGHTEN ANY OF THE SCREWS, AS THIS TENDS TO STRIP THREADS CAUSING PROBLEMS IN THE FUTURE. BE SURE RING ON PIN (11) OF FIGURE 3 IS SECURELY FASTENED OVER LATCH (10). THIS WILL PREVENT LATCH FROM MOVING, SHOULD THE SOCKET HEAD SCREWS (9) LOOSEN DURING OPERATION.

⚠ DANGER:

ALWAYS DISCONNECT ELECTRICAL POWER SOURCE WHEN CLEANING, MAINTAINING OR REPAIRING THIS MACHINE....

REPLACEMENT OF PISTON RING

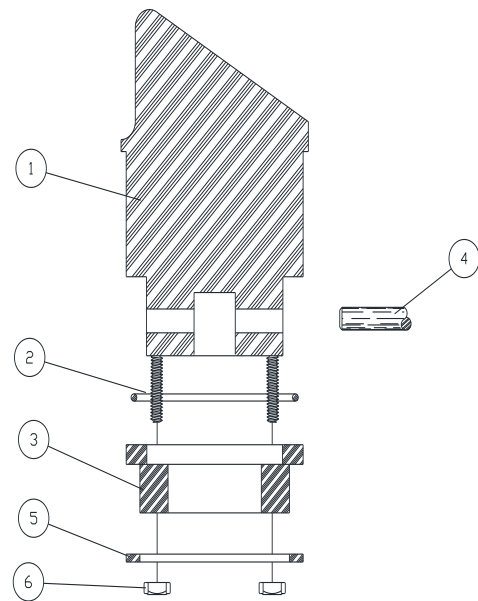

FIGURE 4

TO DISMANTLE PISTON IN FIGURE 4, REMOVE THE SIX HEX NUTS (6), SLIP RING (5) DOWN AND OFF, THEN WITH SLIGHT PRESSURE, PUSH PISTON RING (3) OFF PISTON AND RUBBER "O" RING (2). WHEN REASSEMBLING THE PISTON, A VERY IMPORTANT STEP IS TO MAKE SURE THE SIX NUTS (6) ARE NOT OVERLY TIGHTENED, MERELY SNUG. AS THE RING WEARS OVER A PERIOD OF TIME, CONTINUE TO SNUG UP THE SIX NUTS. THIS PROCEDURE WILL NOT ONLY PROVIDE LONG LIFE TO THE PISTON RING BUT WILL MAINTAIN FULL VACUUM.

GUIDE TO GENERAL MAINTENANCE

READ AND FOLLOW MAINTENANCE INSTRUCTIONS:

BELOW TO HELP KEEP THE UNIT IN GOOD OPERATING CONDITION. REFER TO OTHER MATERIAL RECEIVED WITH THE UNIT AND TO SERVICE BULLETINS FROM THE MANUFACTURER FOR ADDITIONAL INSTRUCTIONS FOR PROPER MAINTENANCE AND SERVICE. REGULAR INSPECTIONS AND PROPER MAINTENANCE IS ESSENTIAL TO HELP PREVENT ACCIDENTS AND INJURIES.

PRACTICE SAFETY FIRST:

ALWAYS DISCONNECT ELECTRICAL SERVICE WHEN CLEANING OR MAINTAINING THIS MACHINE, THUS AVOIDING THE CHANCE OF SERIOUS INJURIES. MACHINES ARE NOT DANGEROUS IF COMMON SENSE IS APPLIED AND THE INSTRUCTIONS ARE CAREFULLY FOLLOWED. THINK AND PRACTICE SAFETY FIRST...

WARNING:

BEFORE MAKING ANY INSPECTION, ADJUSTMENT OR REPAIR, BE CERTAIN POWER SOURCE IS DISCONNECTED AND ALL MOVING PARTS ARE BLOCKED OUT TO PREVENT INJURY. WEAR PROTECTIVE CLOTHING.

- A. ALL WORKING SURFACES SHOULD BE CLEANED REGULARLY.
- B. MAKE SURE THAT ALL FASTENERS ARE TIGHTENED SECURELY.
- C. MAKE CERTAIN THAT ALL GUARDS AND COVERS ARE IN PLACE.
- D. CHECK FOR WORN, DAMAGED OR MISSING PARTS INCLUDING BELTS, SAFETY GUARDS AND PROTECTIVE COVERS.
- E. ON A DAILY BASIS, INSPECT THE UNIT AND CHECK TO BE CERTAIN THAT ALL SYSTEMS ARE OPERATING NORMALLY. DETAILED INSPECTION AND TESTING PROCEDURES ARE SPECIFIED FOR VARIOUS COMPONENTS AT REGULAR INTERVALS. SET UP A CHART AND ASSIGN RESPONSIBILITY FOR THESE ITEMS.

CAUTION:

REPLACE ANY DAMAGED OR MISSING SAFETY LABELS. THEY ARE AVAILABLE FROM THE MANUFACTURER.

MAINTENANCE FOR THE SAB-802 ALWAYS BEGINS WITH KEEPING THE MACHINE CLEAN. PROPER CLEANING PROCEDURES CAN BE FOUND ON PAGES 2 – 4 & 36 OF THIS MANUAL. STANDARD LONG TERM MAINTENANCE CONSISTS OF LUBRICATING MAIN WEAR POINTS OF THE MACHINE WITH AN ALL-PURPOSE LITHIUM BASE GREASE. A GREASE GUN WITH A FLEXIBLE HOSE IS NEEDED.

ALL RECOMMENDATIONS FOR MAINTENANCE ARE BASED ON A 7 DAY, 8 HOUR PER DAY WORK SCHEDULE.

THERE ARE (5) GREASE FITTINGS LOCATED ON THE ROCKER ARM AND DIVIDER FRAME, (FIG. 1). THESE FITTINGS SHOULD BE LUBRICATED BI-WEEKLY FOR OPTIMUM BEARING LIFE.

FOLLOW NORMAL CLEANING AND MAINTENANCE PROCEDURES OUTLINED IN THIS MANUAL. FOR FURTHER ASSISTANCE CONTACT THE A.M. MFG. SERVICE DEPARTMENT AT (800) 342-6744...

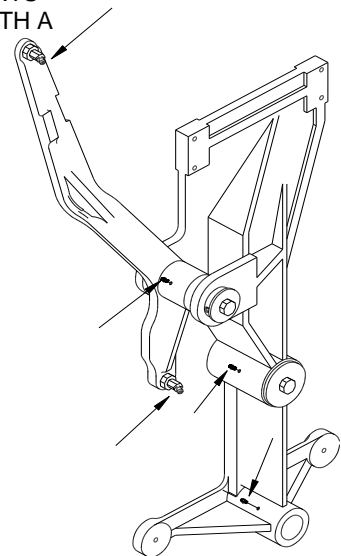



DANGER:

ALWAYS DISCONNECT ELECTRICAL SERVICE WHEN CLEANING, MAINTAINING OR REPAIRING THIS MACHINE.

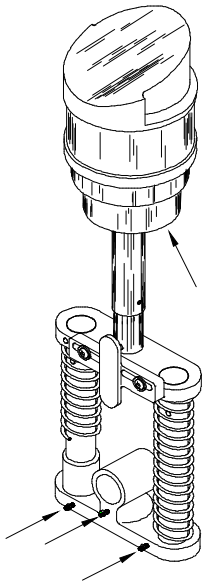

FIGURE 2

THE PISTON AND SPRING LOAD ASSEMBLY HAVE A TOTAL OF (4) GREASE FITTINGS, (FIG. 2). THREE (3) OF THESE FITTINGS ARE FOUND ON THE LOWER CASTING OF THE SPRING LOAD. APPLY A SMALL AMOUNT OF GREASE TO THESE FITTINGS BI-WEEKLY. THE SAME PROCEDURE SHOULD BE FOLLOWED FOR THE GREASE FITTING UNDER THE PISTON, (FIG. 4). THIS FITTING IS LOCATED ON THE TOP OF THE OUTSIDE CONNECTING ROD, (PART NO. 322PY).

NOTE:

THIS FITTING CAN ONLY BE REACHED WITH A FLEXIBLE HOSE GREASE GUN OR BY REMOVING THE PISTON.



YOU MAY FIND UPON INSPECTION OF THE PISTON THAT THE DOUGH HAS SEEPED INTO THE CUP. THIS IS A NORMAL OCCURRENCE AFTER MODERATE PRODUCTION. TO KEEP THE RUBBER "O" RING FROM PREMATURELY DETERIORATING, STRETCHING OR BREAKING, INSPECT AND CLEAN EVERY (4) WEEKS IN THE FOLLOWING MANNER, (FIG. 3). DISASSEMBLE THE PISTON BY REMOVING THE HEX NUTS ON THE BASE OF THE PISTON ASSEMBLY. REMOVE THE STEEL WASHER (PART NO. 302PY) AND PLASTIC PISTON RING (PART NO. 323PY). CAREFULLY CLEAN EXCESS DOUGH FROM THE PISTON AND "O" RING. REASSEMBLE THE PISTON BEING CAREFUL NOT TO OVERTIGHTEN THE PISTON RING.

FOLLOWING NORMAL CLEANING AND MAINTENANCE PROCEDURES OUTLINED IN THIS MANUAL. FOR FURTHER ASSISTANCE CONTACT THE A.M. MFG. SERVICE DEPARTMENT AT (800) 342-6744...

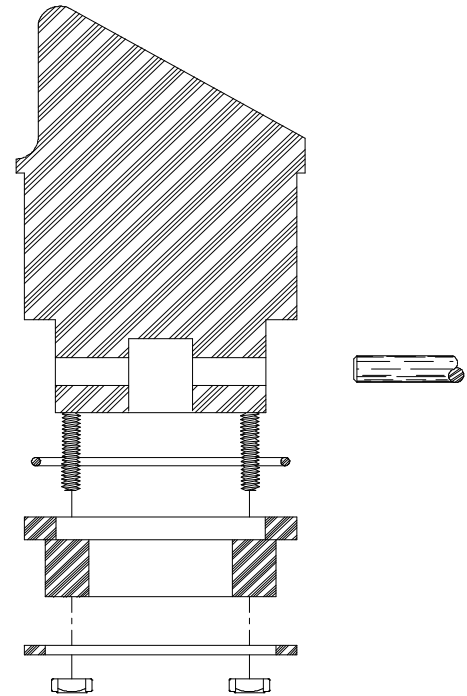

NOTE:

THESE INSTRUCTIONS WILL HELP YOU SERVICE THE UNIT. INSTRUCTIONS ARE FOR A PERSON WITH SOME MECHANICAL ABILITY AND TRAINING. NO ATTEMPT HAS BEEN MADE TO DESCRIBE ALL BASIC STEPS, FOR EXAMPLE, HOW TO LOOSEN OR TIGHTEN FASTENERS. ALSO, BASIC PROCEDURES LIKE HOW TO CYCLE SYSTEMS AND CHECK OPERATION OF THE EQUIPMENT ARE NOT DESCRIBED SINCE THEY ARE KNOWN TO ANYONE WHO DOES MECHANICAL AND SERVICE WORK. DO NOT ATTEMPT TO PERFORM WORK BEYOND YOUR ABILITY OR AT WHICH YOU HAVE NO EXPERIENCE. IF YOU NEED ASSISTANCE, CALL AN AUTHORIZED SERVICE CENTER OR CONTACT A.M. MANUFACTURING AT (800) 342-6744...

**THIS PAGE HAS BEEN
INTENTIONALLY LEFT BLANK**

CABINET ASSEMBLY

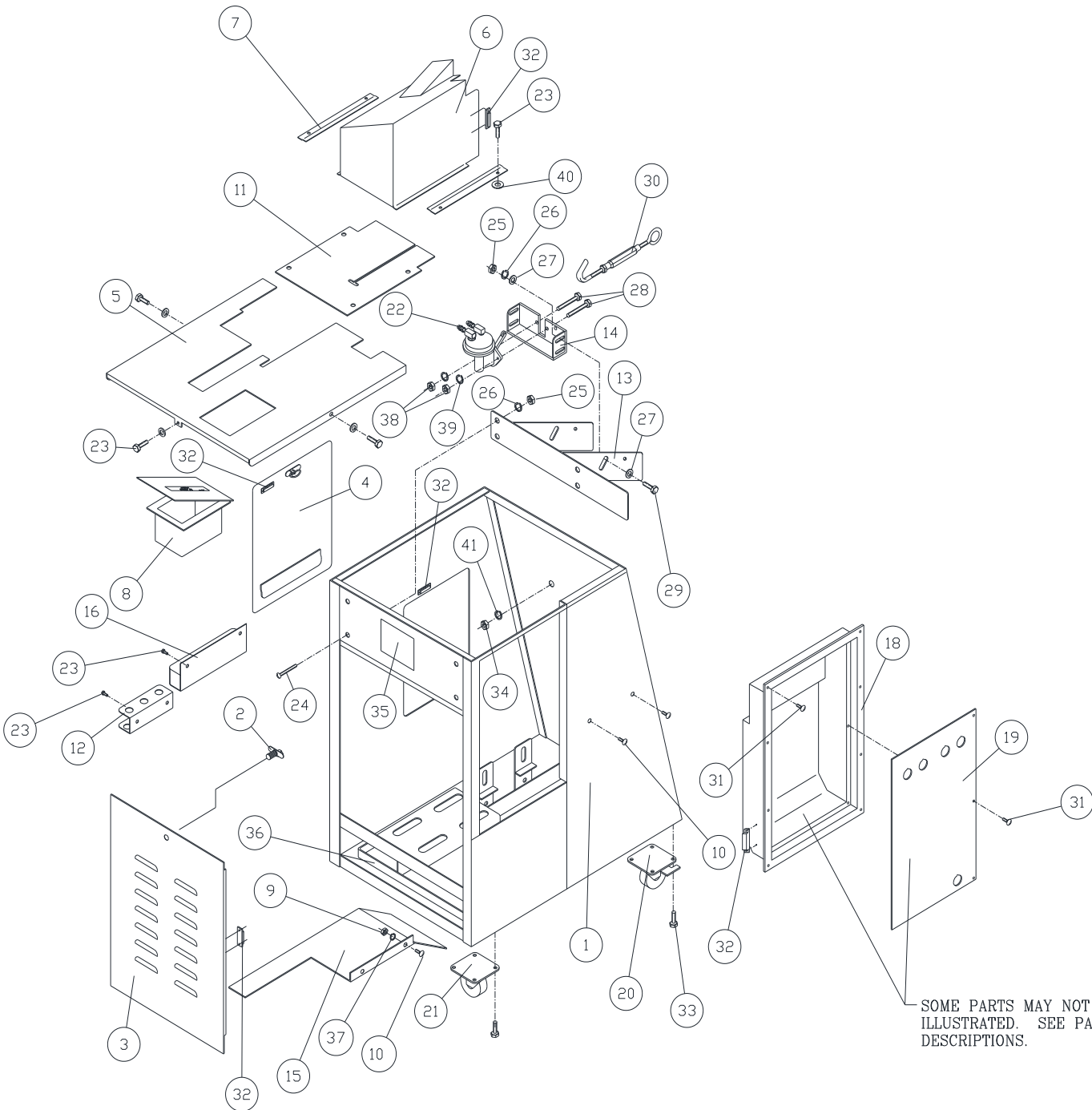

SOME PARTS MAY NOT BE EXACTLY AS ILLUSTRATED. SEE PAGES "37-39" FOR MORE DESCRIPTIONS.

CABINET ASSEMBLY

BILL OF MATERIAL

ITEM	PART NO	DESCRIPTION	QTY
1	20930	CABINET	1
2	646CA1	DOOR LOCK LATCH w/2 POP RIVETS	2
3	CA602A	615CA REAR DOOR (INSPECTION) w/646CA1 HARDWARE	1
4	11810A	11810 FRONT DOOR PISTON DRIVE w/646CA1 HARDWARE	1
5	602CA	TOP COVER	1
6	641CA/641CA1	ROCKER ARM SAFETY COVER/R. ARM GASKET	1/1
7	640CA	ROCKER ARM COVER TRACK	2
8	604CA	OIL BOX AND COVER	1
9	F0400NC	NUT	2
10	F0402TH	BOLT	3
11	641CA1	ROCKER ARM COVER GASKET	1
12	638CA	TOOL HOLDER	1
13	605CA1	PUMP BRACKET (LARGE)	1
14	605CA2	PUMP BRACKET (SMALL)	1
15	643CD	"V" BELT GUARD	1
16	11866	NUT BOX	1
17	F9901PH	SCREW	18
18	617CA6	ELECTRICAL ENCLOSURE	1
19	11423/TAG #37	ELECTRICAL COVER PANEL w/ STICKER	1
20	621CA1	SWIVEL CASTER (LOCKING)	2
21	621CA2	SWIVEL CASTER	4
22	7160S	OIL PUMP W/CLEVIS	1
23	F0402HH	BOLT	11
24	F0503CB	BOLT	4
25	F0500NC	NUT	6
26	F0500LW	LOCK WASHER	6
27	F0500FW	FLAT WASHER	8
28	F0606HH	BOLT	2
29	F0504HH	BOLT	4
30	654CA	TURN BUCKLE	1
31	F9901PH	SCREW	14
32	EL-1308	SAFETY INTERLOCK SWITCH	3
33	F0404ST	BOLT	16
34	F0600NC	NUT	4
35	19904	ELECTRICAL PLATE	1
36	19905	OIL PAN (FOR DOUGH)	1
37	F0400LW	LOCK WASHER	2
38	F0600NC	NUT	6
39	F0600LW	LOCK WASHER	6
40	F0400FW	FLAT WASHER	4
41	F0600FW	FLAT WASHER	4



IMPORTANT:

KNOW YOUR UNIT. COMPARE DIAGRAMS IN THIS MANUAL WITH THE UNIT BEFORE STARTING SERVICE TO OBTAIN MAXIMUM SAFETY AND PERFORMANCE.

HOPPER COVER (STANDARD)

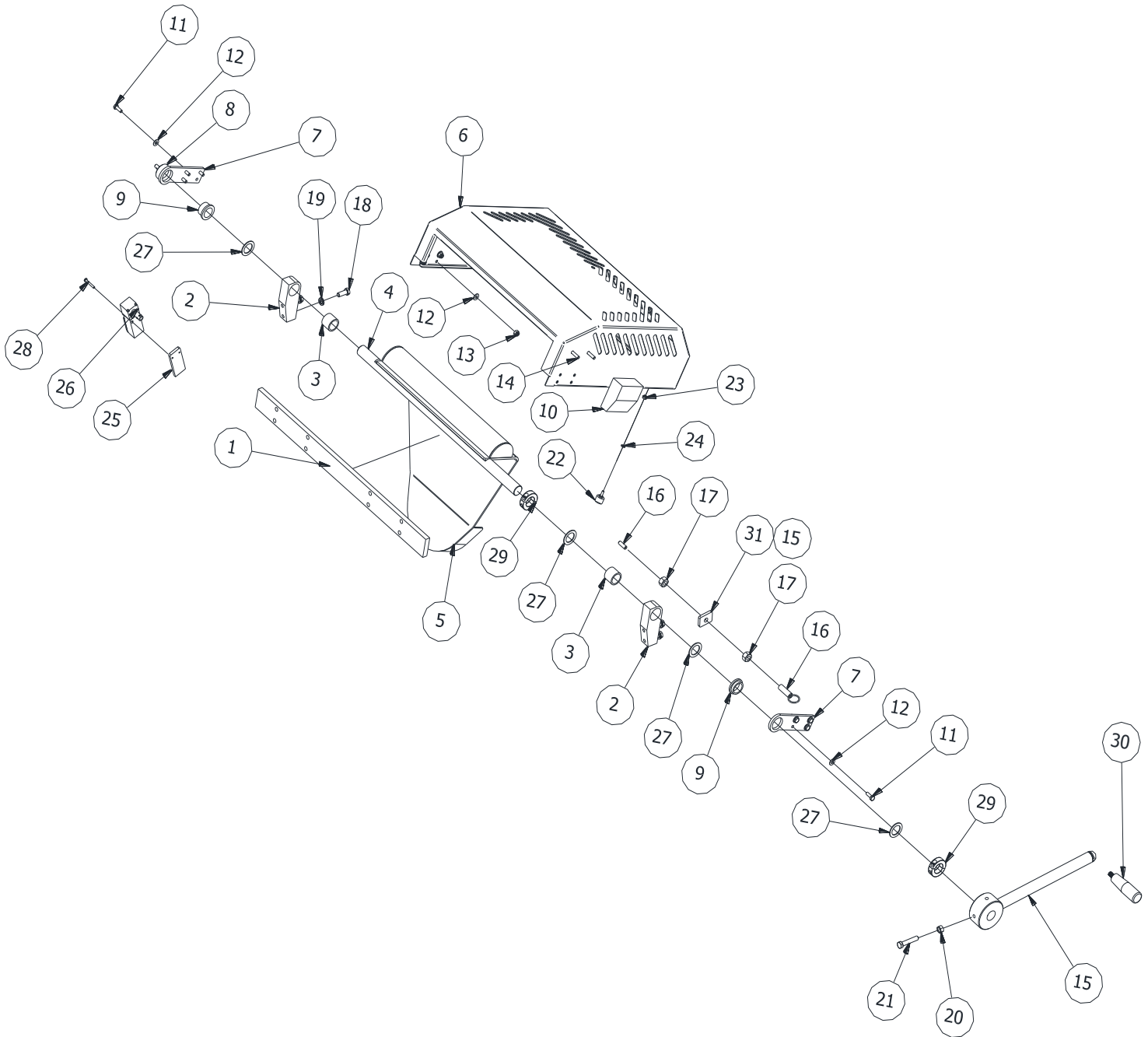

**ITEM #25 IS WELDED TO ITEM #1. SHOWN APART FOR CLEARTY
ITEMS #4 & #5 ARE PURCHASED AS AN ASSEMBLY**

NOTE:

GUARDS ARE INTERLOCKED; MACHINE WILL NOT OPERATE WITHOUT GUARDS IN PLACE.

HOPPER COVER (STANDARD)

BILL OF MATERIAL

ITEM	PART NO	DESCRIPTION	QTY
1	17832	SAFETY COVER MOUNTING BAR	1
2	17828	SAFETY COVER HINGE BASE	2
3	20614	OIL IMPREGNATED SLEEVE BUSHING (1.002 ID X 1.253 OD X 1" LONG)	2
4	17890	SAFETY COVER PIVOT SHAFT (PURCHASE AS ASSEMBLY W/ 17827)	1
5	17827	DOUGH FEED PLATE ASSEMBLY (PURCHASE AS ASSEMBLY W/ 17890)	1
6	17834	HOPPER SAFETY COVER	1
7	17842	HOPPER SAFETY COVER HINGE PLATES	2
8	17888	SAFETY COVER SAFETY SWITCH ADAPTER (PUCHASED AS ASSEMBLY W/ 17842)	1
9	20453	OIL IMPREGNATED FLANGE BUSHING (1.002 ID X 1.253 OD X 3/4" LONG)	2
10	19475	SAFETY COVER PIVOT LOCK BLOCK`	1
11	F0403HHCS	HEX HEAD CAP SCREW 1/4-20 X 3/4"	8
12	F0400FW	FLAT WASHER, 1/4"	16
13	F0400NLN	NUT, NYLOCK 1/4"	8
14	F0404SB	BUTTON HEAD, SOCKET 1/4-20 X 1" LG	2
15	17824	SAFETY COVER DOUGH HANDLE ASSY.	1
16	20432	SPRING PLUNGER w/ PULL RING	1
17	F0800NC	NUT COURSE, 1/2-13 NORMAL	2
18	F0604HHCS	HEX HEAD CAP SCREW 3/8-16 X 1"	4
19	F0600LW	LOCK WASHER 3/8"	4
20	F0600NC	NUT COURSE, 3/8	1
21	F0608HHCS	HEX HEAD CAP SCREW 3/8-16 X 2" LG	1
22	11832	BUMPER, THREADED STUD W/HEX SHOULDER	2
23	F9900NLN	NYLOCK NUT, #10-32	2
24	F9900FW	FLAT WASHER, # 10	2
25	19220	SAFETY SWITCH MOUNT PLATE	1
26	EL-1320	SAFETY SWITCH - ROTARY HINGE - 2NC	1
27	20615	NYLON WASHER (1.003" I.D. X 1-1/2" O.D. X 1/16" THICK)	4
28	F9705PHS	PAN HEAD, SLOTTED, 8-32 UNC x 1-1/4	2
29	20616	1" S.S. SPLIT SHAFT COLLAR (2 PIECE)	2
30	11467	EASY-TURN REVOLVING HANDLE 3/8"-16 THRD STUD, 1.10" Dia., 3.54" LG	1
31	19476	SNAP PIN MOUNTING TAB	1

HOPPER COVER (EXTENDED)

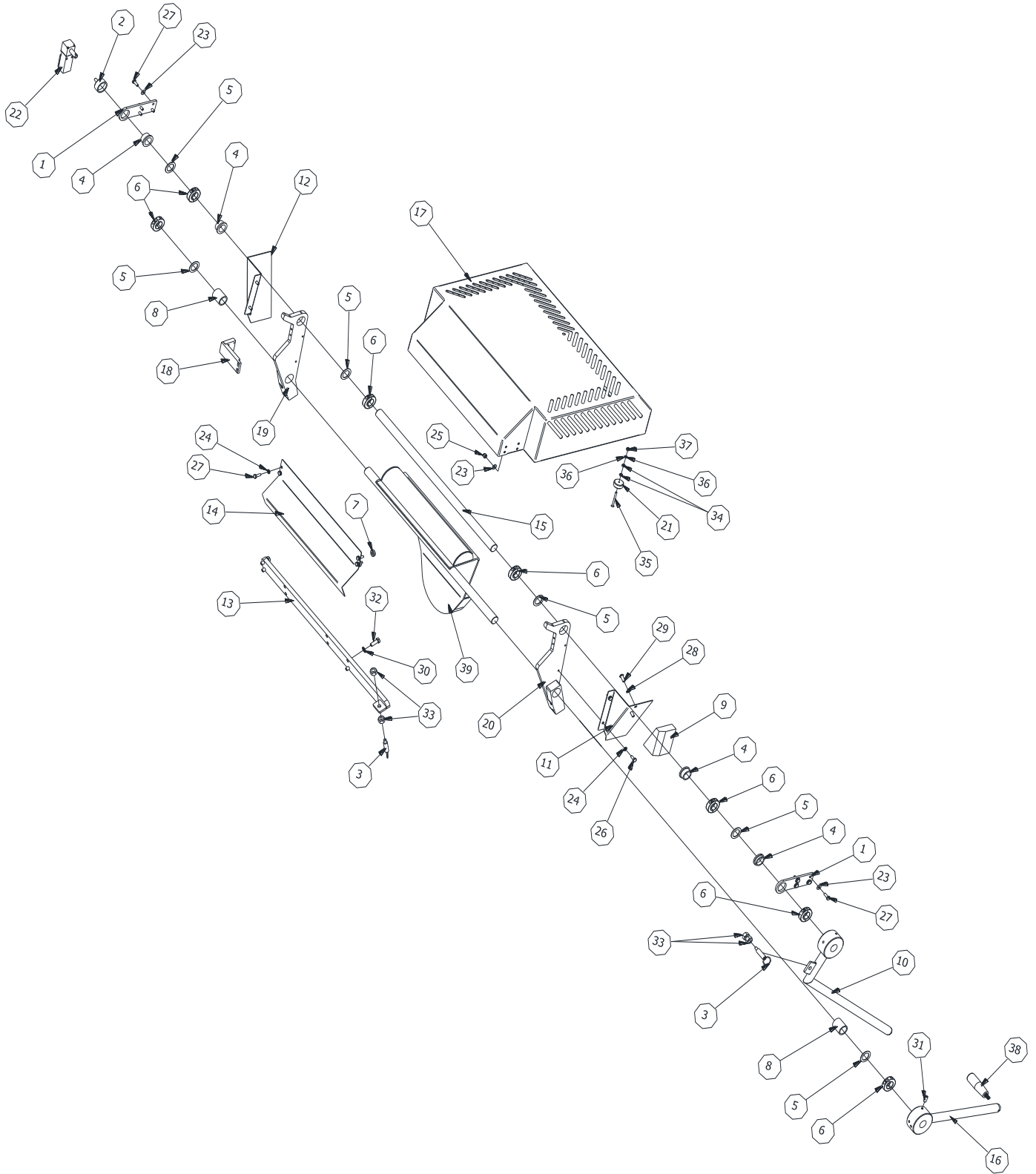

HOPPER COVER (EXTENDED)

BILL OF MATERIAL

ITEM	PART NO	DESCRIPTION	QTY
1	17842	HOPPER SAFETY COVER HINGE PLATES	2
2	17888	SAFETY COVER SAFETY SWITCH ADAPTER	1
3*	20432	SPRING PLUNGER w/ PULL RING	2
4	20453	OIL IMPREGNATED FLANGE BUSHING (1.002 ID X 1.253 OD X 3/4" LONG)	4
5	20615	NYLON WASHER (1.003" I.D. X 1-1/2" O.D. X 1/16" THICK)	6
6	20616	1" S.S. SPLIT SHAFT COLLAR (2 PIECE)	7
7	20645	SPACER (3/4" O.D. X 1/4" LONG w/ 9/32 THRU HOLE)	2
8	20649	OIL IMPREGNATED SLEEVE BUSHING (1.002 ID X 1.253 OD X 1.5" LONG)	2
9	20650	SPRING PIN LOCK BLOCK	1
10	20651	SAFETY COVER HANDLE ASSEMBLY	1
11	20657	HOPPER GUARD (LEFT SIDE)	1
12	20658	HOPPER GUARD (RIGHT SIDE)	1
13	20660	SAFETY COVER MOUNTING BAR ASSEMBLY	1
14	20661	HOPPER BACK GUARD	1
15	20662	SAFETY COVER PIVOT SHAFT	1
16	20663	SAFETY COVER DOUGH HANDLE ASSY.	1
17	20665	EXTENDED HOPPER SAFETY COVER	1
18	20666	INTERLOCK SWITCH MOUNT BRACKET ASSEMBLY	1
19	20669	SAFETY COVER HINGE BAR (RIGHT SIDE)	1
20	20670	SAFETY COVER HINGE BAR (LEFT SIDE)	1
21	20671	HOPPER COVER BUMPER	2
22	EL-1320	SAFETY SWITCH - ROTARY HINGE - 2NC	1
23	F0400FW	FLAT WASHER, 1/4"	16
24	F0400LW	LOCK WASHER, 1/4"	8
25	F0400NLN	NUT, NYLOCK 1/4"	8
26	F0402.5HHCS	HEX HEAD CAP SCREW 1/4-20 X 5/8"	4
27	F0403HHCS	HEX HEAD CAP SCREW 1/4-20 X 3/4"	12
28	F0500LW	LOCK WASHER, 5/16"	2
29	F0503SB	SOCKET BUTTON HEAD, 5/16-18 X 3/4" LG	2
30	F0600LW	LOCK WASHER 3/8"	4
31	F0603SS	3/8-16 S.S. SET SCREW 3/4" LONG	2
32	F0604HHCS	HEX HEAD CAP SCREW 3/8-16 X 1"	4
33*	F0800NC	NUT COURSE, 1/2-13 NORMAL	4
34	F9800NC	NUT COURSE, #10-24	4
35	F9808FSH	10-24 X 2" LONG FLAT SOCK HEAD SCREW	2
36	F9900FW	FLAT WASHER, # 10	2
37	F9900NLN	NYLOCK NUT, #10-32	2
38	11467	EASY-TURN REVOLVING HANDLE 3/8"-16 Thrd Stud, 1.10" Dia, 3.54" LG	1
39	20810	DOUGH FEED PLATE & SHAFT ASSEMBLY	1

*** ITEMS 3 & 33 ARE SOLD AS A UNIT. SHOWN APART FOR CLERTY**

DIVIDER SLIDE GUARD ASSEMBLY

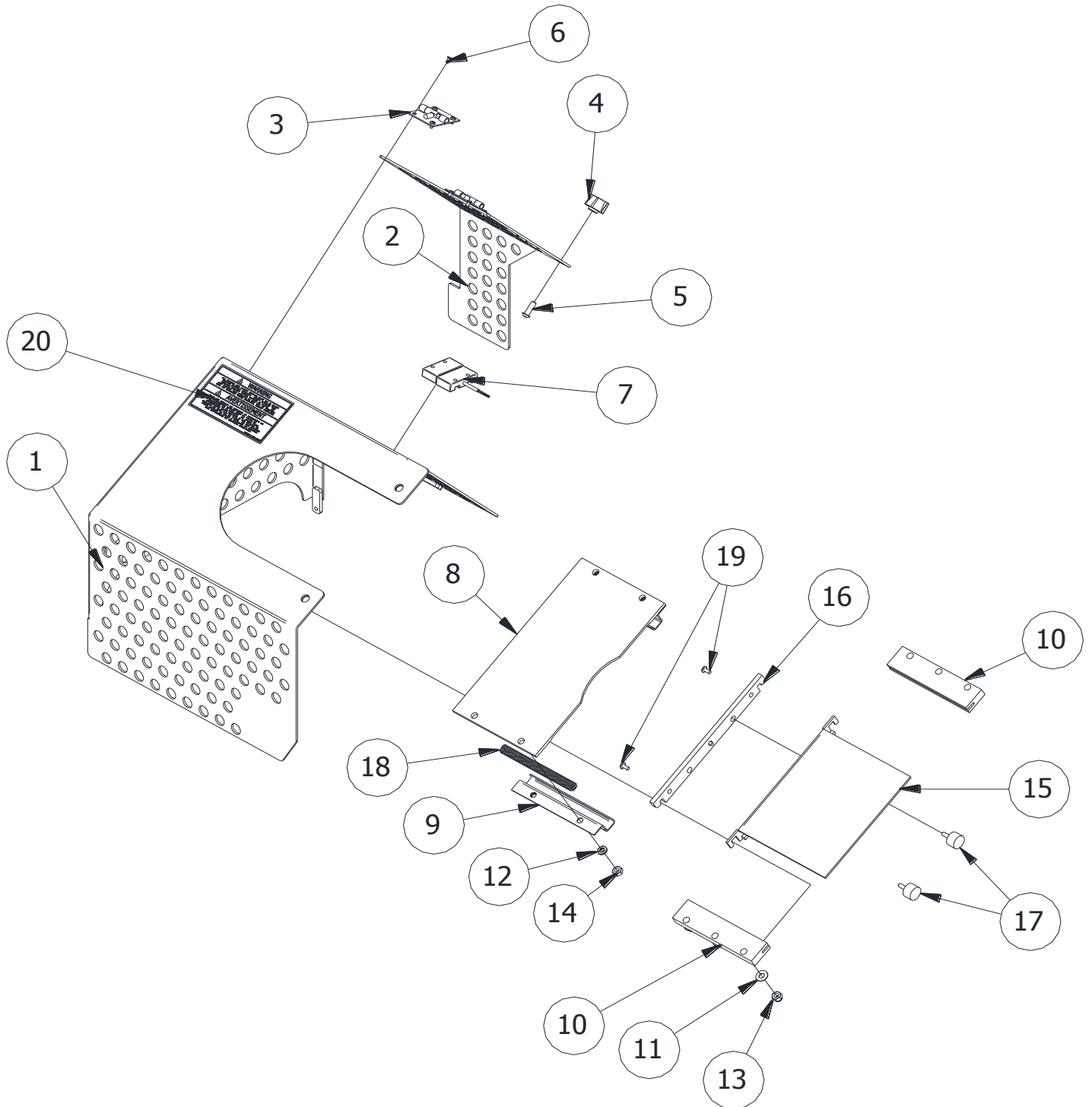

DIVIDER SLIDE GUARD ASSEMBLY

BILL OF MATERIAL

ITEM	PART NO	DESCRIPTION	QTY
1	21029	GUARD MAIN BODY ASSEMBLY	1
2	21030	GUARD CAGE DOOR	1
3	11831	HINGE SET	1
4	F0400PWN	PLASTIC WING NUT (1/4-20)	1
5	F0403SB	BUTTON HEAD, SOCKET 1/4-20 X 3/4" LG, S.S.	1
6	F9601FH	PAN HEAD, SLOTTED, 6-32 UNC x 0.25	8
7	EL-1308	SAFETY SWITCH - CODED SENSOR / ACTUATOR	1 SET
8	11826	SLIDE SPACER	1
9	11825	SPRING RETAINER	2
10	11824	GUARD SLIDE TRACK	2
11	F0400FW	FLAT WASHER, 1/4"	6
12	F0400LW	LOCK WASHER, 1/4"	4
13	F0400NLN	NUT, NYLOCK 1/4"	6
14	F0400NC	NUT COURSE, 1/4-20	4
15	11823	GUARD SLIDE ASSEMBLY	1
16	12114	GUARD SLIDE ADAPTER	1
17	11832	BUMPER, THREADED STUD W/HEX SHOULDER	2
18	11830	SPRING 1/2" OD X 5" LG	2
19	F9701.5TH	8-32 X 3/8" LONG TRUSS HEAD	3
20	AMTAG11SF	STICKER, GUARD WARNING LABEL (ENGLISH & CANADIAN FRENCH)	1

NOTE:

GUARD CAN BE PURCHASED AS A COMPLETE UNIT. PART # 21028

CYLINDER AND DRIVER ASSEMBLY

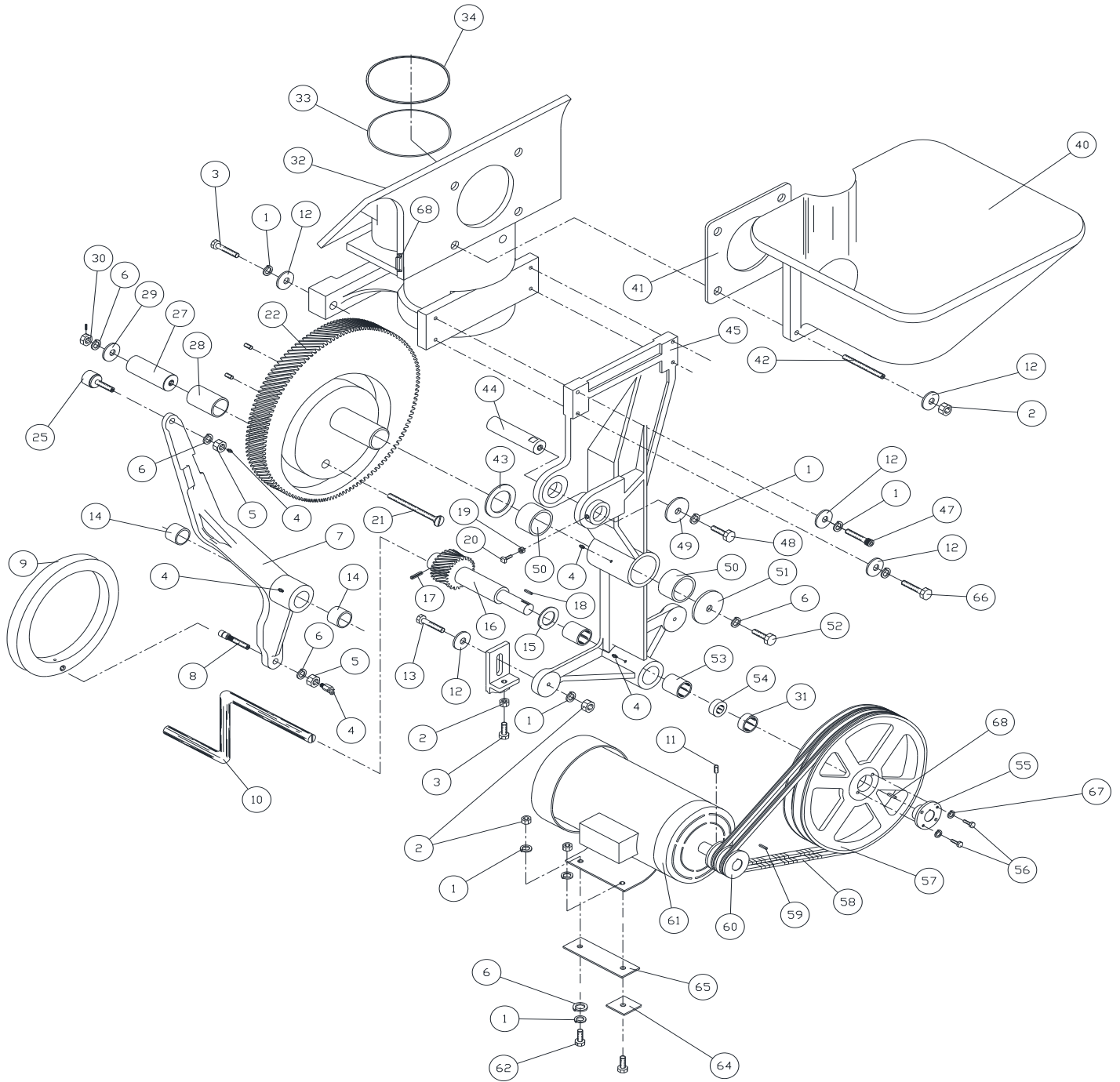

CYLINDER AND DRIVER ASSEMBLY

BILL OF MATERIAL

ITEM	PART NO	DESCRIPTION	QTY
1	F0600LW	LOCK WASHER	13
2	F0600NC	NUT	12
3	F0604HH	BOLT	2
4	3038-B	GREASE FITTING	5
5	F0800NF	NUT	2
6	F0800LW	LOCK WASHER	4
7	AS0110CD	ROCKER ARM COMPLETE	1
		INCLUDES:	
		1-412CD CAM ARM PIN	
		2-422CD BEARINGS	
		1-427CD CAM ROLLER W/WASHER, NUT (A427CD)	
		GREASE FITTING (3038-B)	
		1-448CD CAM TRACK SHOE	
		1-452CD SHOE BOLT W/ WASHER, NUT (A427CD)	
8	A452CD	GREASE FITTING	1
		SHOE BOLT W/ WASHER, NUT,	
		GREASE FITTING	
9	448CDA	HEAVY DUTY CAM TRACK SHOE	1
10	426CD	HAND CRANK	1
11	F0501SS	SET SCREW	1
12	F0600FW	FLAT WASHER	12
13	F0607HH	BOLT	2
14	422CD	ROCKER ARM BEARING	2
15	416CD	WASHER SPACER	1
16	415CD-H	DRIVE SHAFT & PINION	1
		INCLUDES:	
		1-F0404KY KEY	
17	F0305RP	1-F0305RP ROLL PIN	1
18	F0404KY	ROLL PIN	1
		KEY W/ 415CD (NOT SOLD ALONE)	
19	F0500NC	NUT	1
20	F0506SQ	BOLT	1
21	F0819FH	BOLT	1

CYLINDER AND DRIVER ASSEMBLY

BILL OF MATERIAL CONT.

ITEM	PART NO	DESCRIPTION	QTY	
22	S0113CD	MAIN DRIVE GEAR	1	
		INCLUDES:		
		1-SCREW		
		1-406CD SHAFT YOKE PIN		
		1-NUT		
		1-SPRING		
		1-409CD SHAFT		
		1-CRANK PIN SCREW		
		1-LOCK WASHER		
		1-FLAT WASHER		
		1-312PY BEARING		
		25		A427CD
SHAFT YOKE PIN (NOT SOLD ALONE) W/S0133CD ONLY	1			
27			406CD	
28	312PY	DRIVE BEARING	1	
29	459CD	SPACER	1	
30	F0800NC	NUT	1	
31	464CD	SPACER	1	
32	AS0107CD	CYLINDER	1	
		INCLUDES:		
		1-7080S CHECK VALVE		
		8-F0500CN NUTS 8-F0508SD STUDS		
33	402CD	CYLINDER SLIDE "D" RING	1	
34	401CD	SEAL SCRAPER RING	1	
35	456CD	CLAMP, COVER, L.H. HINGE	1	
36	454CD	HOPPER COVER	1	
37	460CD	INSULATORS	2	
38	455CD	CLAMP, COVER R.H. HINGE	1	
39	461CD	BOLTS FOR HINGES	2	
40	445CD	DOUGH HOPPER	1	
	445CDE	EXTENDED DOUGH HOPPER (OPTIONAL)		
41	449CD	HOPPER GASKET	1	
42	F0607SD	STUD	4	
43	411CD	SPACER WASHER	1	

CYLINDER AND DRIVER ASSEMBLY

BILL OF MATERIAL CONT.

ITEM	PART NO	DESCRIPTION	QTY
44	412CD	CAM ARM PIN	1
45	S0109CD	MAIN DRIVE FRAME	1
		INCLUDES:	
		2-437CD PINION SHAFT BEARING	
		2-440CD MAIN FRAME BEARING	
		2-3038-B GREASE FITTING	
	2- NUTS		
47	F0609SH	BOLT	1
48	F0604HH	BOLT	1
49	442CD	WASHER, 1-3/4 X 3/8	1
50	440CD	MAIN FRAME BEARING	2
51	439CD	WASHER 3 X 9/16	2
52	F0804HH	BOLT	1
53	437CD	PINION SHAFT BEARINGS	2
54	465CD	BEARING	1
55	463CD	HUB-PULLEY W/ KEY	1
56	F0404HH	BOLT	2
57	435CD	DRIVE PULLEY(SINGLE GROOVE)	1
	435CD2	DRIVE PULLEY(DOUBLE GROOVE)	
	435CDV	DRIVE PULLEY(VARIABLE GROOVE)	
58	434CD-V	"V" BELT (VARIABLE)	1
	434CD49	"V" BELT (49")	
	434CD56	"V" BELT (56")	
59	F0304Y	KEY 3/16"	1
60	458CD	MOTOR PULLEY (SINGLE GROOVE)	1
	458CDD	MOTOR PULLEY (DOUBLE GROOVE)	
	458CDV	MOTOR PULLEY (VARIABLE)	
61	SS268	ELECTRIC MOTOR (SINGLE PHASE)	1
	SS265	ELECTRIC MOTOR (3 PHASE)	
	SS264	ELECTRIC MOTOR (VARIABLE)	
62	F0605HH	BOLT	4
63	462CD	MOTOR MOUNT	1
64	644CA	MOTOR SPACER	2
65	643CA	MOTOR SHIM	2
66	F0404KY	KEY	1
67	F0400LW	LOCK WASHER	2
68	SS240	MAGNETIC REED SWITCH	1

MEASURING CUP & DIVIDER SLIDE ASSEMBLY

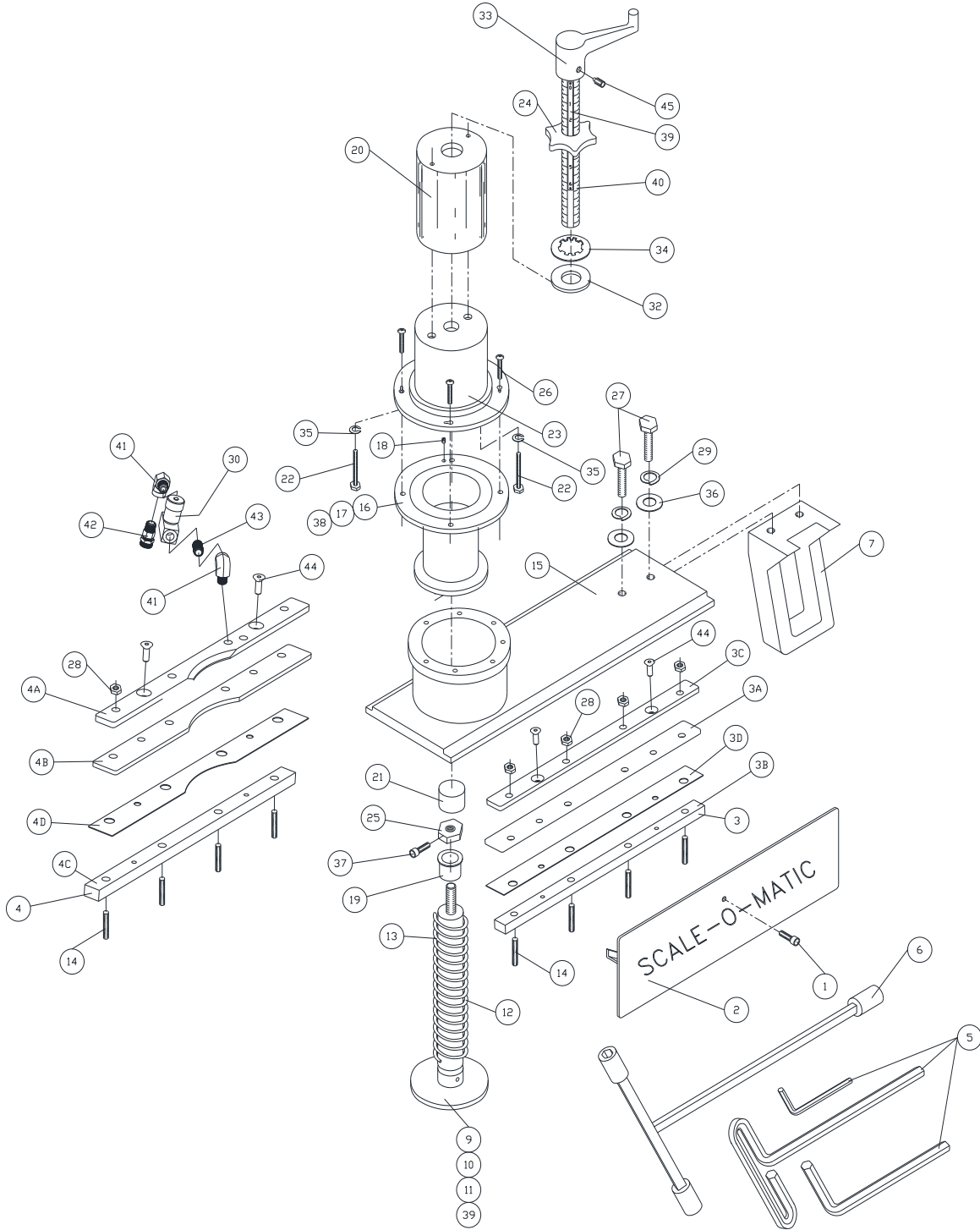

MEASURING CUP & DIVIDER SLIDE ASSEMBLY BILL OF MATERIAL

ITEM	PART NO	DESCRIPTION	QTY
1	F0404SH	SOCKET HD. BOLT	1
2	518MS	NAME PLATE & OIL RETURN	1
3	21641	GIB BAR LOWER INCLUDES:	1
		3A. 506MS-B (PLASTIC INSERT)	
		3B. 507MS (SPACER BAR)	
		3C. 520MS (GIB BAR, LOWER)	
		3D. 521MS-B (WEAR STRIP, LOWER)	
4	21640	GIB BAR UPPER INCLUDES:	1
		4A. 505MS (GIB BAR, TOP)	
		4B. 506MS-T (PLASTIC INSERT)	
		4C. 507MS (SPACER BAR)	
		4D. 521MS-T (WEAR STRIP, TOP)	
5	530MSW	WRENCHES	1 SET
		1/8", 1/16", 5/32" T-HANDLE	
6	542MSW	T WRENCH	1
7	517MS	CAM ARM SLIDE W/ F0607HH SCREWS	
9	513MS-2	2" PLUNGER W/ SPRING	1 UNIT
		W/1-F0304RP ROLL PIN	
		1-516MSL PLUNGER SPRING (LIGHT)	
10	513MS-3	3" PLUNGER	1 UNIT
		W/1-F0304RP ROLL PIN	
	513MS-3S	3" PLUNGER W/ SPRING	1 UNIT
		W/1-F0304RP-ROLL PIN	
		1-515MS PLUNGER SHAFT	
		1-516MSH PLUNGER SPRING (HEAVY)	
11	513MS-5	5" PLUNGER	1 UNIT
		W/1F0304RP ROLL PIN	
	513MS-5S	5" PLUNGER W/SPRING	
		W/1F0304RP ROLL PIN	
		1-516MSH PLUNGER SPRING (HEAVY)	
12	516MSL	PLUNGER SPRING (LIGHT)	1
		FOR 2" PLUNGER	
13	516MSH	PLUNGER SPRING (HEAVY)	1
		FOR 3" & 5" PLUNGER	
14	F0508SD	STUD	8
15	511MS	DIVIDER SLIDE	1
16	509MS	DIVIDER CYLINDER 2"	1
17	510MS	DIVIDER CYLINDER 3"	1

MEASURING CUP & DIVIDER SLIDE ASSEMBLY BILL OF MATERIAL CONT.

ITEM	PART NO	DESCRIPTION	QTY
18	F0401SSS	SET SCREW	4
19	539MSP	PLASTIC BUSHING	1
20	529MS-2	STOP COVER	1
21	529MS-2E	PLASTIC STOP PLUG	1
22	F0416HH	BOLT	2
23	503MS	PLUNGER GUIDE HOUSING	1
		W/1-S543MS THREADED INSERT	
24	529MS-2D	STAR KNOB	1
25	531MS	SLOTTED HEX NUT	1
26	F0404SB	SOCKET HEAD BOLT	4
27	F0607HH	HEX HEAD BOLT	2
28	F0500HNC	HEX NUT	8
29	F0600LW	LOCK WASHER	2
30	724OS	STREET ELBOW 90°	1
31	7110S	1/2" or 1" LINE	
32	F1200WF	WASHER	1
33	529MS-2F	ADJUSTABLE HANDLE	1
34	F1200RW	RETAINING WASHER	1
35	F0400LW	LOCK WASHER	2
36	F0600HFW	FLAT WASHER	2
37	F0403SH	SOCKET HEAD BOLT 3/4" LONG	1
38	512MS	DIVIDER CYLINDER 1"	1
39	513MS-1	1-1/2" PLUNGER	1
		W/1-F0304RP ROLL PIN	
	513MS-1S	1-1/2" PLUNGER W/ SPRING	1 UNIT
		1-515MS PLUNGER SHAFT	
		1-516MSL PLUNGER SPRING (LIGHT)	
40	529MS-2C	MEASURING CUP ADJUSTMENT STUD	1
41	724OS	STREET ELBOW, 90 DEGREE	2
42	7220S	MALE CONNECTOR - HOSE	1
43	7370S	PIPE COUPLING	1
44	F0403FSH	FLAT SOCKET HEAD BOLT	4
45	F0502SSDP	SET SCREW W/ FULL DOG POINT	1

INDIVIDUAL MEASURING CUP ASSEMBLIES

AMS1 FOR 1oz. TO 2oz. PIECES
 AMS2 FOR 2oz. TO 4oz. PIECES
 AMS3 FOR 4oz. TO 10oz. PIECES
 AMS5 FOR 10oz. TO 32oz. PIECES

NOTE:

PART NO. A501MS (COMPLETE STOP COVER ASSEMBLY AVAILABLE TO REPLACE OLD STYLE STOP COVERS).

**THIS PAGE HAS BEEN
INTENTIONALLY LEFT BLANK**

PISTON-CONNECTING ROD & SPRING ASSEMBLY

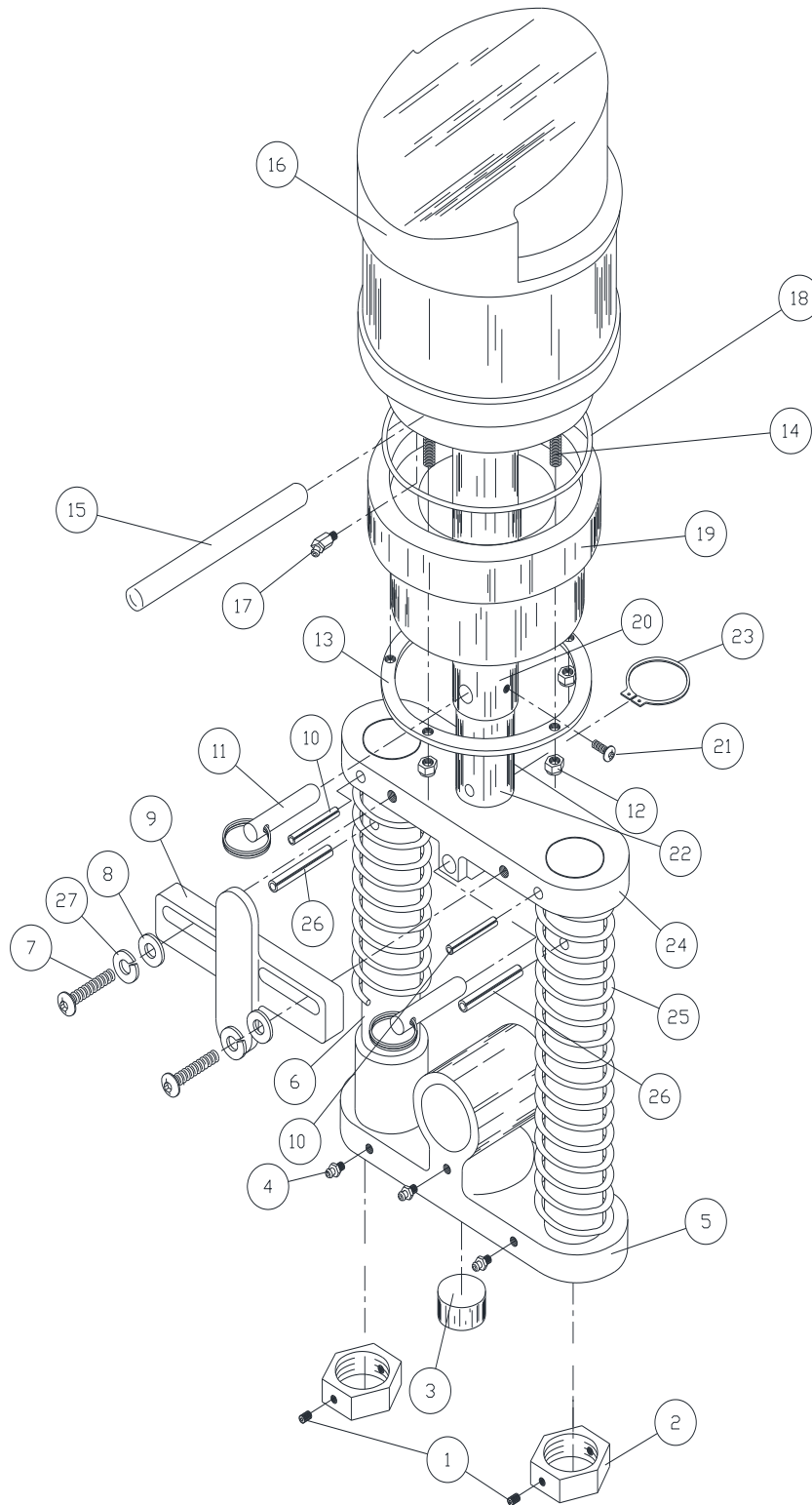

PISTON-CONNECTING ROD & SPRING ASSEMBLY BILL OF MATERIAL

ITEM	PART NO	DESCRIPTION	QTY
***1	F0401SS	SET SCREW	2
***2	315PY	SPRING LOCK NUT	2
***3	313PY	EXPANSION PLUG	1
***4	3038-B	GREASE FITTING	3
***5	310PY	LOWER CASTING & BUSHING W/ 3-3038-B GREASE FITTINGS	1
		1-313PY EXPANSION PLUG	
***6	309PY	SPRING 6" 6WIDE BARS (NOT SOLD SEPARATELY) (SOULD WITH 317PY ONLY)	2
***7	F0404SB	BOLT	2
***8	F0400FW	FLAT WASHER	2
***9	306PY	LOCK CONNECTING PIN	1
***10	F0408RP	ROLL PIN 1/4 DIA. X 2.0" LG.	2
11	304PY	CONNECTING ROD PIN	2
12	F0400LN	LOCK NUT	6
13	302PY	PISTON RING WASHER	1
*14	F0416HS	HANGER SCREW	6
15	301PY	WRIST PIN	1
16	300PYA	PLASTIC PISTON ASSEMBLY W/ 6-FO400LN	1
		LOCK NUTS, 1-301PY WRIST PIN	
		1-302PY PISTON RING WASHER	
		1-323PY PISTON RING ONLY	
		1-324PY O RING	
		HANGER SCREW (6)	
**17	3053-B	GREASE FITTING	1
18	324PY	PISTON O RING	1
19	323PY	PISTON RING ONLY	1
**20	322PY	OUTSIDE CONNECTING ROD	1
**21	F0401SB	SOCKET-BUTTON HEAD SCREW	1
**22	319PY	INSIDE CONNECTING ROD	1
**23	318PY	RETAINER WASHER (TRU ARC)	1
***24	317PY	UPPER SPRING CASTING W/ 2-FO406RP SPRING PINS	1
		2-309PY SPRING GUIDE BARS	
		2-FO408RP SPRING PINS	
***25	316PYB	COMPRESSION SPRING	2
***26	F0406RP	ROLL PIN 1/4 DIA. X 2.0" LG.	2
***27	F0400LW	LOCK WASHER	2

*ITEM IS SOLD SEPARLTY OR AS PART OF ASSEMBLY 300PYA

** ITEM IS SOLD SEPARLTY OR AS PART OF ASSEMBLY A504PY

*** ITEM IS SOLD SEPARLTY OR AS PART OF ASSEMBLY A503PYB

SMALL CONVEYOR & DRIVE ASSEMBLY

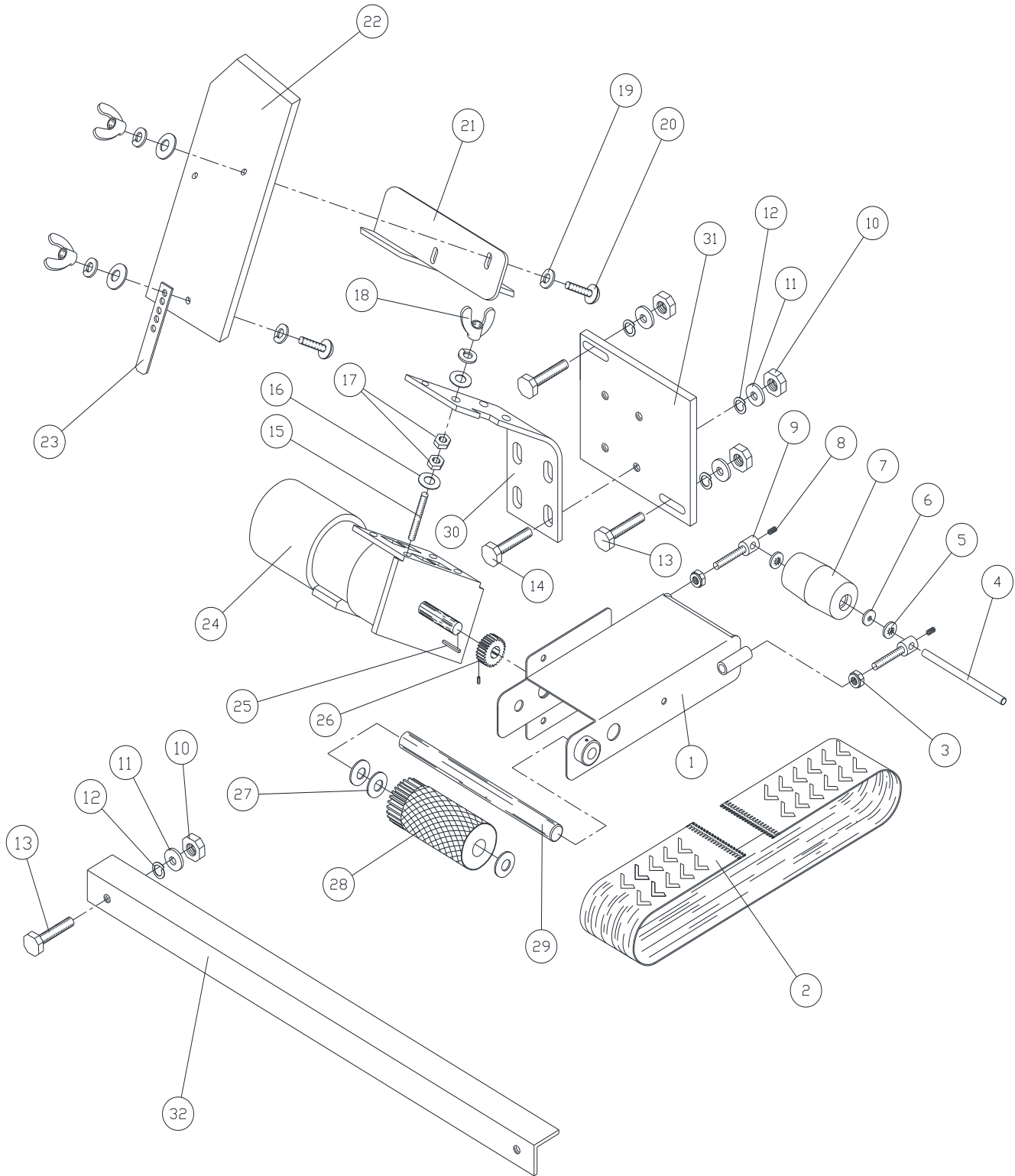

SMALL CONVEYOR & DRIVE ASSEMBLY BILL OF MATERIAL

ITEM	PART NO	DESCRIPTION	QTY
1	BSC67	SMALL CONVEYOR FRAME	1
2	BSC3-4	CONVEYOR BELT	1
3	F0600NC	HEX NUT W/ RUBBER INSERT	2
4	BSC72	IDLER ROLLER SHAFT	1
5	F0600RW	RETAINING WASHER	2
6	641SC2	BALL BEARING	2
7	BSC66	IDLER ROLLER	1
8	F0401SS	SET SCREW	2
9	600SC	ROLLER SUPPORT	2
10	F0600NC	HEX NUT	6
11	F0600FW	FLAT WASHER	6
12	F0600LW	LOCK WASHER	6
13	F0604HH	BOLT	2
14	F0602HH	BOLT	4
15	F0408SD	STUD	4
16	F0400FW	FLAT WASHER	8
17	F0400NC	HEX NUT	8
18	F0400WN	WING NUT	7
19	F0400LW	LOCK WASHER	7
20	F0406RH	BOLT	3
21	BSC63	DOUGH GUIDE SUPPORT	1
22	BSC62-B	PRESSURE PLATE	1
23	BSC62-1	PRESSURE PLATE BRACKET	1
24	SS262	1/6 H.P. GEAR MOTOR	1
25	F0400KY	KEY	1
26	BSC73-1	SPUR GEAR 24T	1
27	F0800WF	FIBER WASHER	3
28	BSC68	DRIVE ROLLER ASSEMBLY	1
29	BSC70	DRIVE ROLLER SHAFT	1
30	BSC65	SMALL CONVEYOR MOUNTING ARM	1
31	BSC64	MOUNTING ARM PLATE	1
32	BSC74	INNER CABINET CONVEYOR SUPPORT BRACE (welded to cabinet)	1

OILING SYSTEM ASSEMBLY

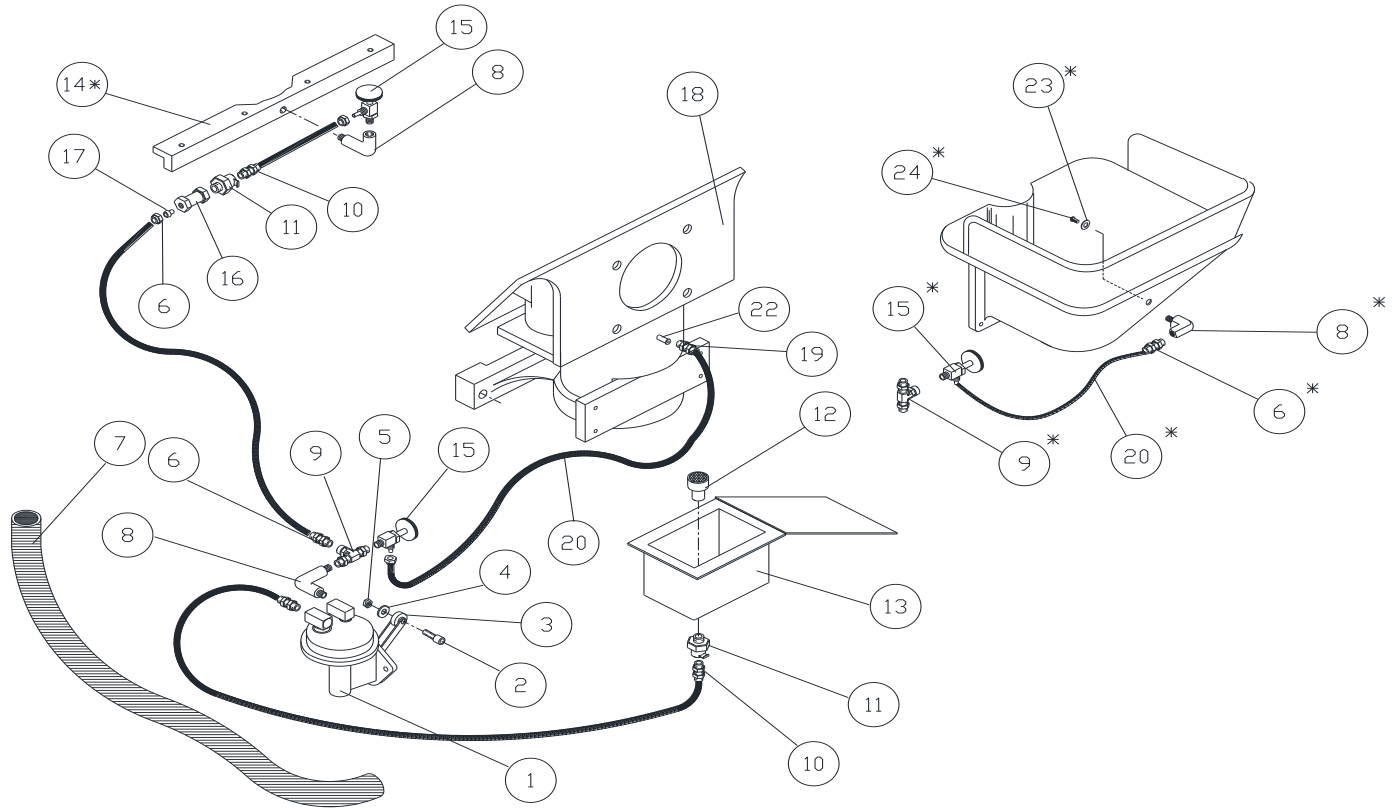

ITEM	PART NO	DESCRIPTION	QTY
1	7000S	OIL PUMP	1
2	F0403SH	BOLT	1
3	7140S	PUMP ROLLER BEARING	1
4	F0400LW	LOCK WASHER	1
5	F0400LN	NYLON LOCK NUT	1
6	7220S	MALE CONNECTOR	3
7	7110S	1/2" OIL DRAIN TUBING 4 FT.	4 FT.
8	7240S	STREET ELBOW 90°	3
9	7250S	STREET "T"	1
10	7260S	QUICK CONNECT, MALE	2
11	7270S	QUICK CONNECT, FEMALE	2
12	7130S	STRAINER W/ INSERT - FILTER ADAPTER	1
13	604CA	OIL BOX	1
14	21640	GIB BAR	1
15	14393	VALVE	2
16	103-B-OZ	BRASS COUPLING	1
17	7090S	PLASTIC FERRULES	10
18	AS0107CD	CYLINDER	1
19	7080S	MALE CHECK VALVE	1
20	7100S	1/4" OIL SYSTEM TUBING 12 FT.	12 FT. / * 2 FT.
21	SS184	PUSH BUTTON (STARTER)	1
22	7280S	BRASS INSERT	1
23	F0400FW	STAINLESS STEEL FLAT WASHER	1
24	7410S	PLUG	1

#14 – SEE PAGE 28 THRU 30 FOR DETAILED GIB BAR COMPONENTS

**THIS PAGE HAS BEEN
INTENTIONALLY LEFT BLANK**

ELECTRICAL CONTROL PANEL



ELECTRICAL CONTROL PANEL BILL OF MATERIAL

ITEM	PART NO	DESCRIPTION	QTY
1	617CA6	ELECTRICAL ENCLOSURE	1
2	TAG #37	ELECTRICAL ENCLOSURE DOOR LABEL	1
3	11423	ELECTRICAL ENCLOSURE PANEL	1
4	SS268	ELECTRICAL SUB PANEL	1
5	EL-0935	IEC MOTOR CONTACTOR (16 AMP)	1
6	EL-0853	IEC MOTOR CONTACTOR (9 AMP)	3
7	EL-0975	DIN RAIL - 4" LONG	2
8	EL-0975	DIN RAIL - 5-7/8" LONG	1
9	SS143	6 POINT TERMINAL BLOCK	1
10	SS176	100VA TRANSFORMER	1
11	SS142	FUSE HOLDER	2
12	SS134	2 AMP FUSE (CLASS CC)	2
13	EL-0856	MANUAL MOTOR STARTER (6.3 - 10 AMPS)	1
14	EL-0854	MANUAL MOTOR STARTER (2.5 - 4.0 AMPS)	1
15	F9702TH	8-32 X 1/2" LONG TRUSS HEAD	20
16	F9700FW	FLAT WASHER #8	22
17	F9700LW	LOCK WASHER #8	22
18	SS181	WIRE DUCT - 1 X 2 X 9" LONG	1
19	SS182	WIRE DUCT COVER - 1" WIDE (9" LONG)	1
20	EL-1371	GROUNDING SCRULUGS	2
21	F9704RH	SCREW (ROUND HEAD) 8-32 UNCX1	2
22	400071	PUSH-IN GROMMETS (1/2")	1
23	EL-0975	DIN RAIL - 4" LONG	1
24	EL-0396	TERMINAL BLOCK END ANCHOR	2
25	EL-0395	TERMINAL BLOCK (TYPE MA2.5/5)	32
26	EL-0417	TERMINAL BLOCK LABEL	64
27	EL-0858	MANUAL MOTOR STARTER (1.6 - 2.5 AMPS)	1
28	EL-0414	KNOB	1
29	F09904SH	SOCKET HEAD CAP SCREW (10-32 X 1" LONG)	6
30	F9900FW	FLAT WASHER, # 10	6
31	F9900LW	LOCK WASHER, #10	8

ELECTRICAL CONTROL PANEL BILL OF MATERIAL CONTINUED

ITEM	PART NO	DESCRIPTION	QTY
32	F9900MSN	10-32 MACHINE SCREW NUT	8
33	F9702TH	8-32 X 1/2" LONG TRUSS HEAD	3
34	F9700LW	LOCK WASHER #8	3
35	12099	IN LINE KNUCLE	2
36	12099	KNUCKLE FRONT MOUNT	2
37	F9901TH	10-32 X 1/4" LONG TRUSS HEAD	4
38	F9902TH	10-32 X 1/2" LONG TRUSS HEAD	6
39	EL-1307	GUARDMASTER SAFETY RELAY	1
40	20452	SAFETY RELAY MOUNT BRACKET	1
41	EL-0975	DIN RAIL - 1-3/4" LONG	1
42	EL-0396	TERMINAL BLOCK END ANCHOR	2
43	SS275	1/2" CORD GRIP (.500 - .625)	1
44	SS276	1/2" CORD GRIP (.625 - .75)	1
45	SS101	1/2" CONDUIT FITTING LOCKNUT	7
46	SS100	3/8 CORD GRIP FITTING	4
47	F9700NC	NUT, COURSE 8-32 HEX	2
48	F0500NC	NUT COURSE, 5/16-18	6
49	SS185	PUSH BUTTON, RED	1
50	20451	EMERGENCY STOP NAMEPLATE	1
51	SS103	FITTING, 90 DEGREE / 3/8" CORDGRIP	1
52	400038	N.C. CONTACT BLOCK	2
53	SS159	FORMER MOTOR PLUG	1
54	SS160	FORMER MOTOR CONNECTOR	1
55	EL-1363	E-STOP CONTROL PLUG (FEMALE)	1
56	EL-1362	E-STOP CONTROL PLUG (MALE)	1
57	SS146	MACHINE CONTROL PLUG	1
58	SS147	MACHINE CONTROL CONNECTOR	1
59	EL-1396	E-STOP PLUG / CONNECTOR ADAPTOR	1
60	SS225	16/4 CABLE (1 @ 88" LONG & 1 @ 42" LONG)	1
61	SS226	16/5 CABLE (1 @ 88" LONG & 1 @ 42" LONG)	1

ELECTRICAL (SCHEMATIC) CONTROL SAFETY CIRCUIT & CONTROL CIRCUIT

— SHEET 2 —

AB SAFETY RELAY

"INTERLOCK SAFETY CIRCUIT & CONTROL CIRCUIT"

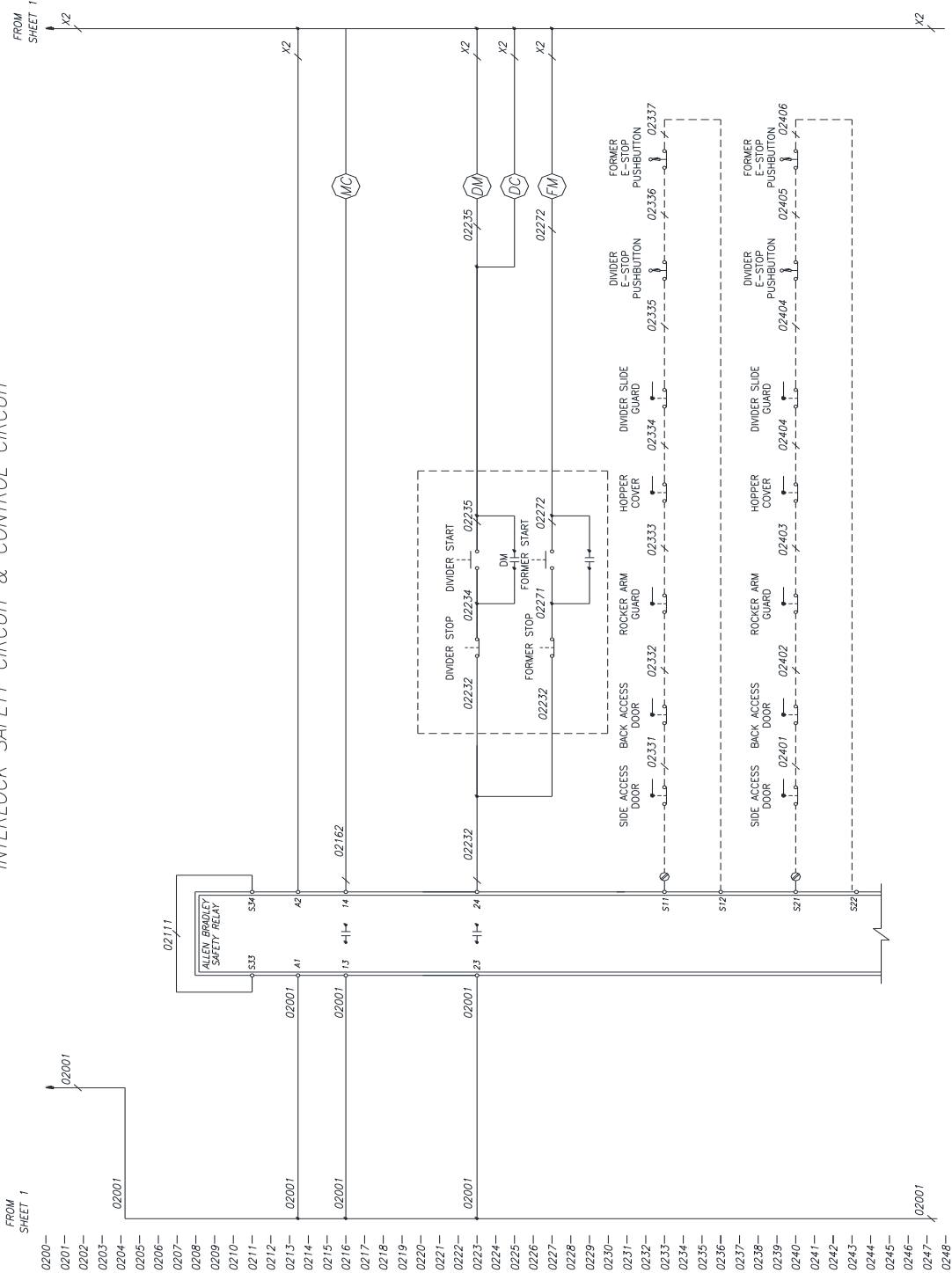

ELECTRICAL (SCHEMATIC) THREE PHASE / 208-230VAC SHEET 1

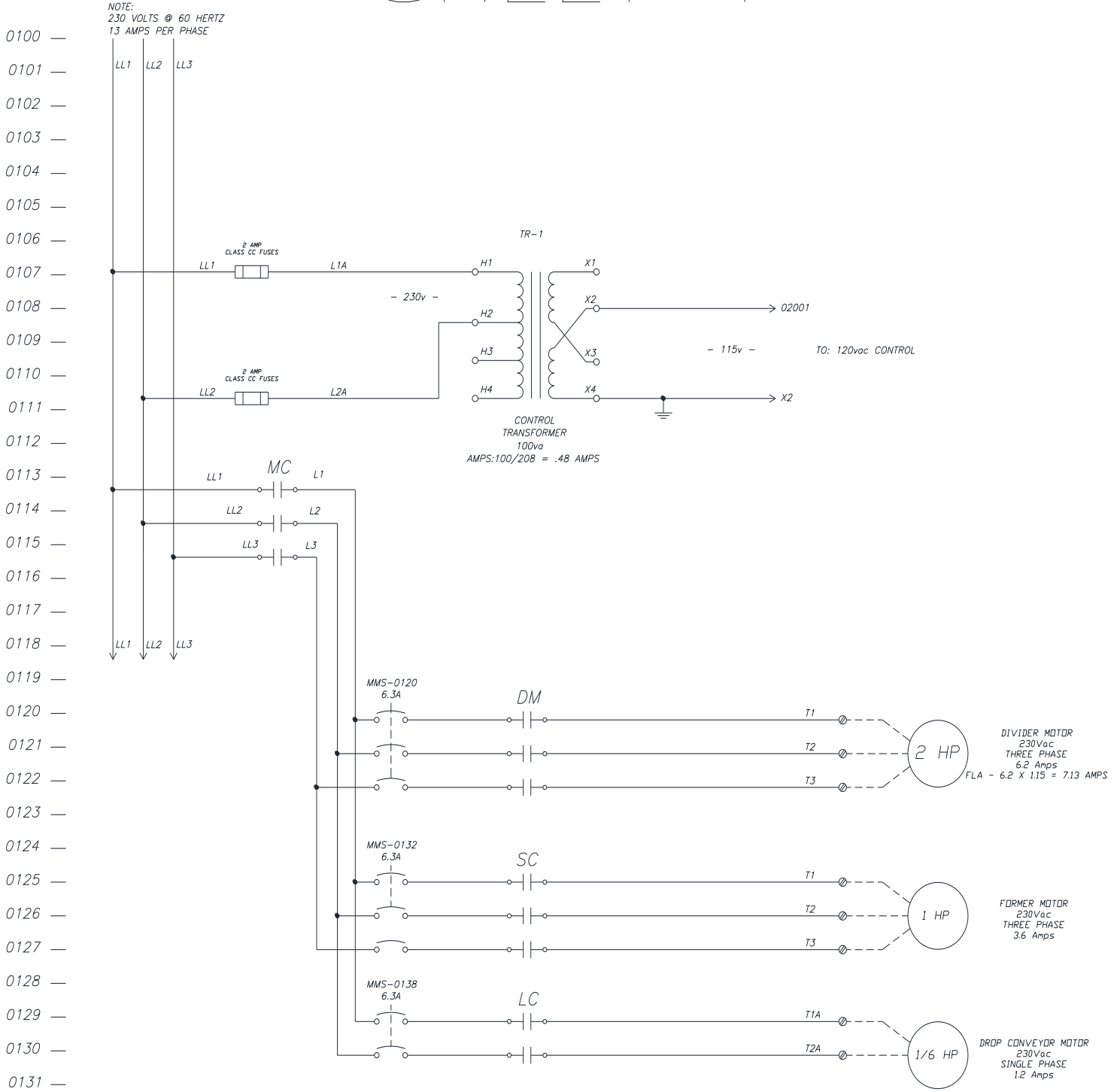

TROUBLESHOOTING



DANGER:
ALWAYS DISCONNECT ELECTRICAL POWER SOURCE
WHEN MAINTAINING OR REPAIRING THIS MACHINE...

NOTE:
GUARDS ARE INTERLOCKED, MACHINE
WILL NOT OPERATE WITHOUT GUARDS
IN PLACE.

THE OPERATION OF THE SCALE - O - MATIC DEPENDS ON VACUUM. FOR TOP PERFORMANCE. THEREFORE CAN ONLY BE REALIZED IF ALL SEAL POINTS ARE IN PROPER ADJUSTMENT. THE FOLLOWING PLACES FOR POSSIBLE LOSS OF VACUUM ARE TO BE CHECKED:

1. PART NO. S0113CD GEAR
MAKE SURE MACHINE IS RUNNING IN THE RIGHT DIRECTION. SEE ARROW ON GEAR.
GEAR MUST TURN CLOCKWISE.
2. PART NO. 402CD-NEOPRENE "O" RING
CHECK FOR SNUGNESS
3. PART NO. 506MS-SLIDE PRESSURE STRIPS-POLYETHYLENE
CHECK FOR LOSS OF COMPRESSIBILITY.
4. PART NO. 521MS SLIDE WEAR STRIP-NYLON
CHECK FOR WEAR.
5. PART NO. 504MS GIB SCREWS
CHECK FOR SNUGNESS
6. PART NO. 323PY PISTON RING
CHECK FOR WEAR-REPLACE IF WORN OR SCORED.
7. PART NO. 503MS MEASURING CUP PLUNGER ROD GUIDE CHECK FOR WEAR AND SMOOTHNESS OF OPERATION. IF WORN PART NO. 513MS WILL BIND OR STICK.
8. PART NO. 513MS PLUNGER
CHECK FOR CIRCUMFERENCE WEAR, REPLACE IF DOUGHS BY-PASS INTO SPRING SECTION.
9. PART NO. 434CD V-BELT DRIVE
KEEP BELT TIGHT TO AVOID SLIPPAGE.
10. PART NO. 401CD SEAL SCRAPER RING
CHECK FOR WEAR AND FOR STRAIGHTNESS.
11. PART NO. S0113CD GEAR
CLEAN CAM TRACK OCCASIONALLY. OBSERVE IF PART NO. 448CD (CAM TRACK SHOE)
IS WORN. ALSO CHECK FOR WEAR ON GEAR CAM TRACK.
12. PART NO. 21640 / 21641 BRONZE GIB BAR
CHECK GIB BARS FOR WEAR AND EXCESSIVE PLAY BETWEEN DIVIDER SLIDE.

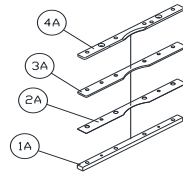
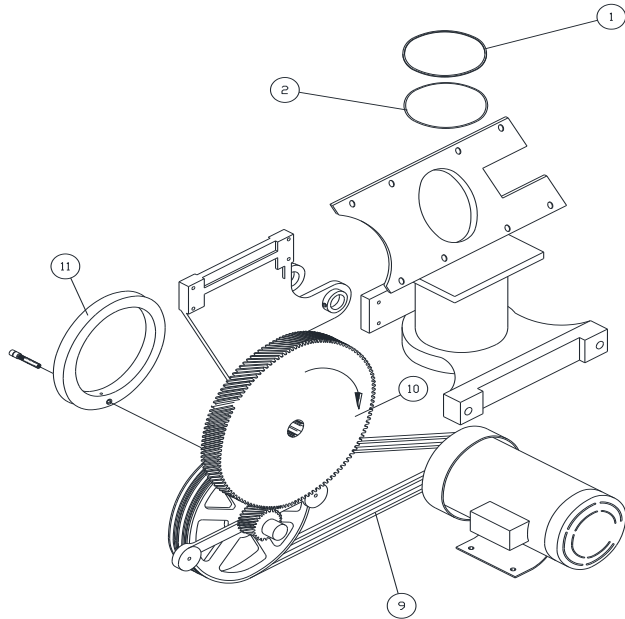
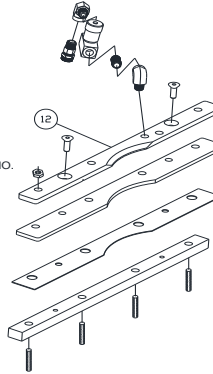
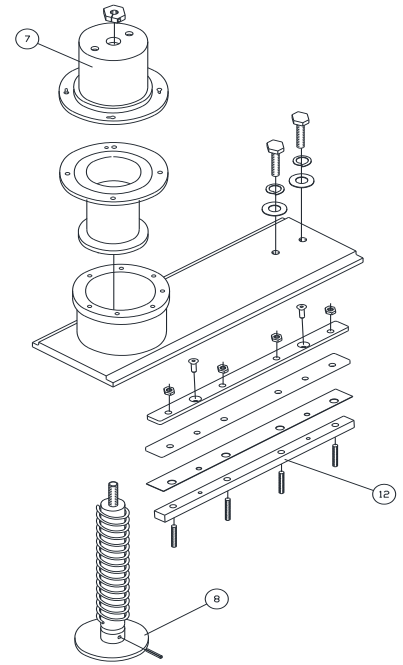

ASSEMBLY INSTRUCTIONS:

- 1A. INSERT SPACER BAR OVER GIB BAR BOLTS FIRST. (507MS)
- 2A. PLACE WEAR STRIP LINER (1/32" X 13" LG.) OVER SPACER BAR. (521MS-T)
- 3A. PLACE PLASTIC WEAR STRIP (1/4" X 13" LG.) OVER LINER. (506MS-T)
- 4A. NOW PLACE TOP GIB BAR OVER PLASTIC WEAR STRIP AND SECURE WITH HEX BOLTS. (505MS)

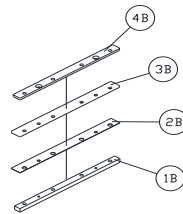

ASSEMBLY INSTRUCTIONS:

- 1B. INSERT SPACER BAR OVER GIB BAR BOLTS FIRST. (507MS)
- 2B. PLACE WEAR STRIP LINER (1/32" X 13" LG.) OVER SPACER BAR. (521MS-B)
- 3B. PLACE PLASTIC WEAR STRIP (1/4" X 13" LG.) OVER LINER. (506MS-B)
- 4B. NOW PLACE TOP GIB BAR OVER PLASTIC WEAR STRIP AND SECURE WITH HEX BOLTS. (505MS)

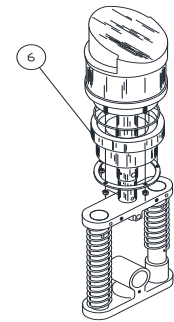

**THIS PAGE HAS BEEN
INTENTIONALLY LEFT BLANK**

OPERATIONS AND SAFETY MANUAL

INCLUDING PARTS CATALOG

**READ AND FAMILIARIZE YOURSELF WITH THIS MANUAL BEFORE OPERATING THIS MACHINE.
FOLLOW INSTRUCTIONS DURING USE.**

INTRODUCTION

THE BF-100 BAGEL FORMER IS DESIGNED TO GIVE YOU OPTIMUM TROUBLE FREE, TIME SAVING SERVICE. IT IS DESIGNED TO FORM THE REQUIRED WEIGHT FOR THE MANDREL USED ON AVERAGE DOUGH. WITH A SPEED RANGE OF UP TO 4800 PIECES PER HOUR, DEPENDING ON SIZE. NEW AND CURRENT EMPLOYEES CAN BE TAUGHT TO OPERATE THIS MACHINE EFFICIENTLY AND SAFELY IN A SHORT PERIOD OF TIME. WE URGE YOU TO STUDY THIS OPERATION AND SAFETY MANUAL FOR FULL BENEFITS.



CAUTION:

ALL OPERATORS MUST BE FULLY TRAINED AND INSTRUCTED IN THESE SAFETY PROCEDURES BEFORE BEGINNING PRODUCTION.

SPECIFICATIONS

SPEED	UP TO 4800 PIECES PER HOUR DEPENDING ON SIZE
WIDTH OF MACHINE	30"
WORKING HEIGHT OF MACHINE	34" - 42"
HEIGHT OF MACHINE	51"
LENGTH OF MACHINE W/ROTARY TABLE	97"
LENGTH OF MACHINE W/OUT ROTARY TABLE	84"
1 MOTOR STARTER - TO OPERATE FORMER	
SHIPPING WEIGHT	450 lbs.

FORMER	3 PHASE, 1 H.P. MOTOR
CONVEYOR BELT	COTTON, STANDARD 180" X 9" WIDE ADJUSTABLE TIGHTENER
BAGEL MANDRELS	FULLY ADJUSTABLE FOR CENTERING 1 1/2" TO 2" DIAMETER OTHER SIZES AVAILABLE PER REQUEST
2 WORK TABLES	1 - STATIONARY - 17" X 23" 1 - REVOLVING - 24" DIAMETER

**ALL MOVING PARTS, WITH EXCEPTION OF NECESSARY CONVEYING SURFACES
SHOULD BE COVERED AND GUARDED WHEN THE MACHINE IS IN OPERATION.**

INSTALLATION INSTRUCTIONS

LOCATION:

SELECT LOCATION CAREFULLY. THE AREA SHOULD PROVIDE THE OPERATOR WITH ENOUGH SPACE TO USE THE EQUIPMENT IN A SAFE MANNER. THE FLOOR AREA SELECTED SHOULD BE EASY TO CLEAN AND SHOULD BE FREE OF OIL, GREASE, ETC. THE UNIT WILL NEED CLEARANCE AROUND IT FOR DOORS AND GUARD REMOVAL.



CAUTION:

PROPER UNIT INSTALLATION IS NECESSARY FOR SAFE AND EFFICIENT OPERATION. PROPER INSTALLATION ALSO HELPS PROTECT THE UNIT FROM DAMAGE AND MAKES SERVICE EASIER.

WARNING LABEL LOCATION

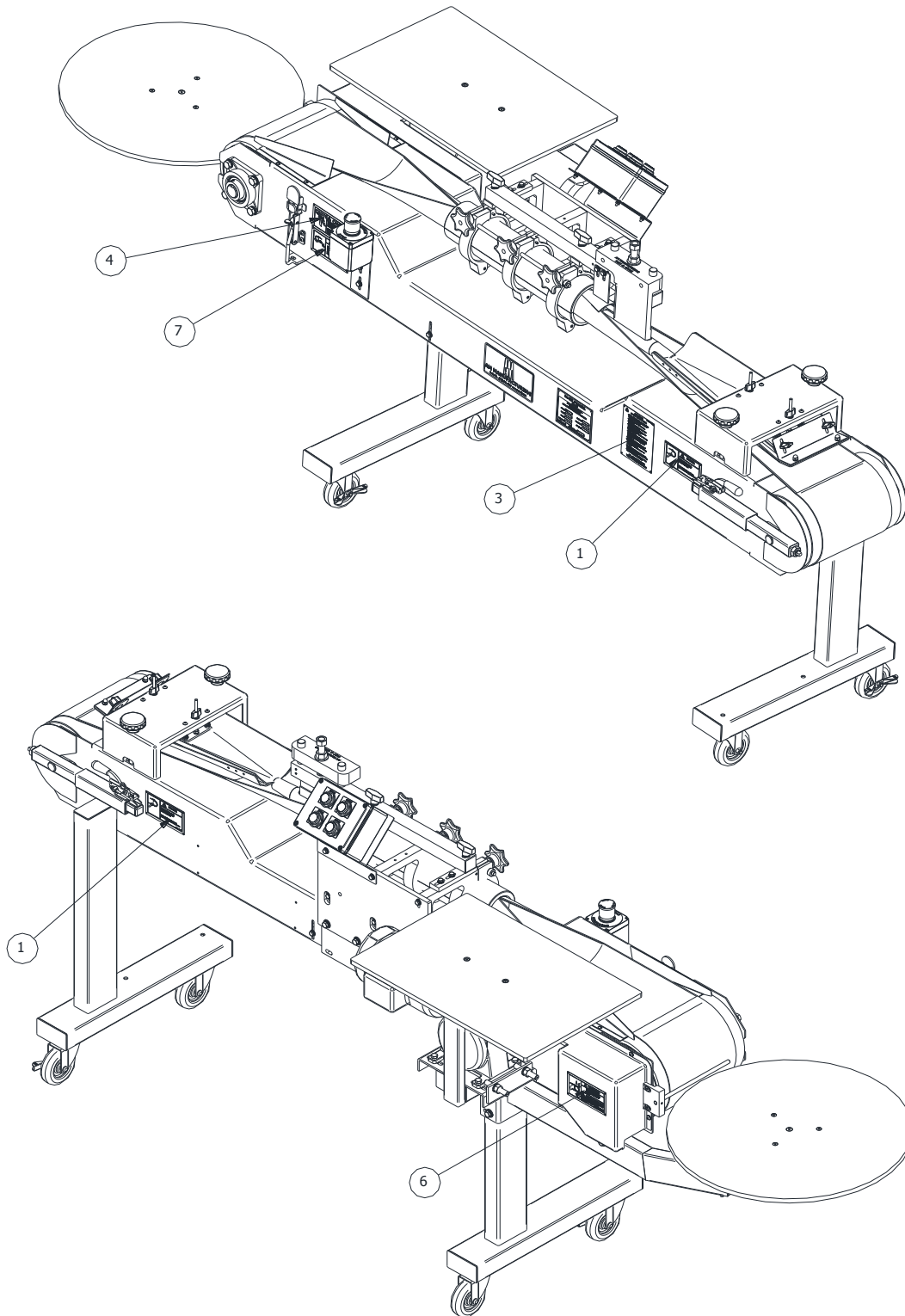

TYPICAL WARNING LABELS FOUND ON THE BAGEL FOMER

- 1 PART NO. AM MFG. #14M
RIGHT / LEFT SIDE OF MAIN FRAME AT
IDLER PULLEY END

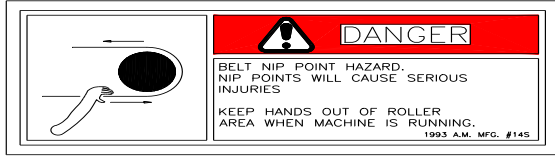

- 2 PART NO. AM MFG. #11
TOP OF THE DOCKER ROLLER COVER

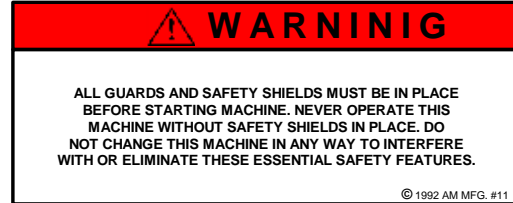

- 4 PART NO. AM MFG. #25
LOCATED OPPOSITE SIDE OF CHAIN GUARD

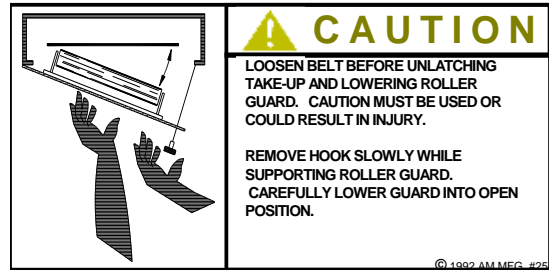

- 3 PART NO. AM MFG. #21
-ON THE DOOR OF THE ELECTRICAL
PANEL

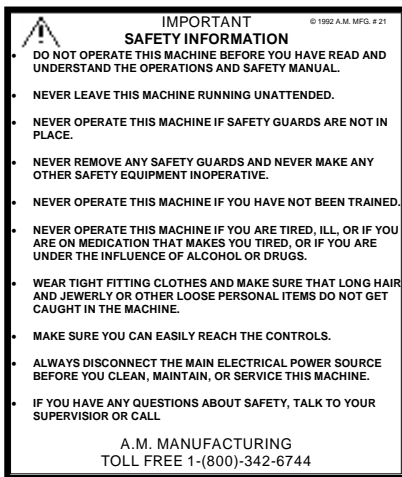

- 6 PART NO. AM MFG. #24
ON THE MOTOR GUARD

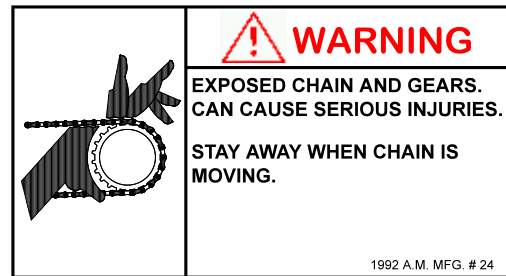

- 7 PART NO. AM MFG. #9A
RIGHT / LEFT SIDE OF MAIN FRAME AT DRIVE
PULLEY END



- 8 PART NO. AM MFG. #9A ON THE MAIN
MACHINE SIDE RAIL AT THE INFED END OF
THE DOCKER ROLLER COVER.

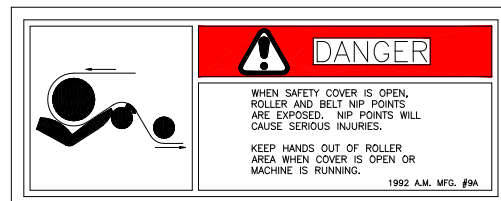

OPERATING INSTRUCTIONS

UNIT MUST BE PROPERLY OPERATED AND MAINTAINED TO PREVENT MACHINE DAMAGE OR PERSONAL INJURY. REVIEW INSTRUCTIONS WITH ALL EMPLOYEES BEFORE USE.



CAUTION:

BEFORE BEGINNING START-UP, READ ALL INSTRUCTIONS AND FAMILIARIZE YOURSELF WITH THE LOCATIONS OF ALL CONTROLS. KNOW HOW TO SHUT DOWN THE UNIT IMMEDIATELY IN CASE OF TROUBLE. MAKE CERTAIN ALL PERSONNEL NOT INVOLVED IN THE START-UP ARE SAFELY AWAY FROM THE MACHINE BEFORE ANY SYSTEMS ARE STARTED.

I. PRELIMINARY START-UP PROCEDURE

- A. PLUG POWER CORD INTO PROPER RECEPTACLE.
- B. PUSH FORMER START BUTTON.
- C. CHECK ROTATION OF DRIVE ROLLERS (100DR) ITEM (1) DRIVE ROLLER ASSEMBLY. IF STANDING IN FRONT OF CONTROL PANEL THE DRIVE ROLLER SHOULD TURN COUNTER CLOCK-WISE (C.C.W.). IF ROTATION IS INCORRECT CONSULT A PROPERLY TRAINED ELECTRICIAN.
- D. IF ROTATION IS CORRECT, YOU ARE READY TO START PRODUCTION.

II. OPERATING THE FORMER

- A. ALL BF-100'S ARE PRE ADJUSTED AND TESTED WITH DOUGH AT THE FACTORY.
- B. IF FURTHER ADJUSTMENTS ARE NEEDED THEY CAN BE MADE AS FOLLOWS:

1. **STOP MACHINE.**
2. IF BAGELS ARE SMALLER ON THE BOTTOM THAN THE TOP, YOU NEED TO RAISE THE MANDREL BAR (BFM12) ITEM (24) FORMING ASSEMBLY (C.W.), OR (C.C.W.). IF THE BAGELS ARE SMALLER ON THE TOP.
3. RESTART THE MACHINE.
4. IF BAGELS ARE SMALLER ON THE RIGHT SIDE, THAN THE LEFT, YOU NEED TO ADJUST THE HORIZONTAL ADJUSTMENT BLOCKS (BFM4) ITEM (6).
5. STOP THE MACHINE
6. LOOSEN THE (4) FOUR SCREWS F0405HHCS ITEM (9) HOLDING THE ADJUSTMENT BLOCKS (BFM4) DOWN.
7. MOVE THE ADJUSTMENT BLOCKS (BFM4) TO THE LEFT SIDE.
8. REVERSE THE STEP IF BAGELS ARE SMALLER ON THE OPPOSITE SIDE.
9. RESTART THE MACHINE.

II. TENSIONING OF BAGEL BELT

- A. TO LOOSEN & TIGHTEN BAGEL BELT.

1. **STOP MACHINE**
2. WITH ADJUSTING KNOB, TURN HEX NUTS LOCATED WITH IN NOTCH AREA AT REAR OF IDLER ROLLER GUARDS. IDLER ROLLER GUARDS ARE SHOWN AS ITEM 4 IN IDLER ROLLER ASSEMBLY DRAWING PAGE 12. TURN HEX NUTS CLOCKWISE TO LOOSEN BELT AND COUNTER CLOCKWISE TO TIGHTEN BELT.
3. NEVER ADJUST ONE HEX NUT INDEPENDENTLY OF THE OTHER MORE THAN FIVE ROTATIONS. DURING THE TIGHTENING OR LOOSENING PROCESS, ALTERNATE FROM RIGHT TO LEFT SIDE EQUALLY ADJUSTING EACH.

- A. TO REMOVE THE BAGEL BELT.

1. **STOP MACHINE**
2. REMOVE PRESSURE PLATE ASSEMBLY BY REMOVING BOTH STAR KNOBS (800PHK) ITEM (23) FORMING ASSEMBLY. SLOWLY LIFT AND REMOVE MOUNTING BRIDGE (104IRA) ITEM (9) IDLER ROLLER ASSEMBLY WITH PRESSURE PLATE ASSEMBLY STILL INTACT.
3. LOOSEN ALL (3) THREE STAR KNOBS (BFM19) ITEM (14) FORMING ASSEMBLY. LOWER ALL (3) THREE FORMING CLAMPS ITEMS (7). REMOVE FORMING TUBES.
4. UNLATCH CLAMP (23).
5. **CAUTION:** UNLATCH CLAMP SLOWLY WHILE SUPPORTING THE BELT TENSION SWING PLATE (115DR-A) ITEM (14). CAREFULLY LOWER GUARD SWING PLATE INTO OPEN POSITION.
6. BAGEL BELT CAN NOW BE REMOVED.

GENERAL MAINTENANCE

READ AND FOLLOW MAINTENANCE INSTRUCTIONS BELOW TO HELP KEEP THE UNIT IN GOOD OPERATING CONDITION. REFER TO OTHER MATERIALS RECEIVED WITH THE UNIT AND TO SERVICE BULLETINS FROM THE MANUFACTURER FOR ADDITIONAL INSTRUCTIONS FOR PROPER MAINTENANCE AND SERVICE. REGULAR INSPECTIONS AND PROPER MAINTENANCE ARE ESSENTIAL TO HELP PREVENT ACCIDENTS AND INJURIES.

WARNING:

BEFORE MAKING ANY INSPECTION, ADJUSTMENT OR REPAIR, BE CERTAIN POWER SOURCE IS DISCONNECTED AND ALL MOVING PARTS ARE BLOCKED OUT TO PREVENT INJURY. WEAR PROTECTIVE CLOTHING.

1. MAKE CERTAIN ALL GUARDS AND COVERS ARE IN PLACE.
2. CHECK FOR WORN, DAMAGED OR MISSING PARTS INCLUDING: BELTS, SAFETY GUARDS AND PROTECTIVE COVERS.
3. MAKE SURE THAT ALL FASTENERS ARE TIGHTENED SECURELY.
4. THE TABLE TOP AND OTHER WORKING SURFACES SHOULD BE CLEANED REGULARLY.
5. ON A DAILY BASIS INSPECT THE UNIT AND CHECK TO BE CERTAIN THAT ALL SYSTEMS ARE OPERATING NORMALLY. DETAILED INSPECTION AND TESTING PROCEDURES ARE SPECIFIED FOR VARIOUS COMPONENTS AT REGULAR INTERVALS. SET UP A CHART AND ASSIGN RESPONSIBILITY FOR THESE ITEMS.

DANGER:

ALWAYS DISCONNECT ELECTRICAL SERVICE WHEN CLEANING, MAINTAINING OR REPAIRING THIS MACHINE.

CAUTION:

REPLACE ANY DAMAGED OR MISSING SAFETY LABELS. THEY ARE AVAILABLE FROM THE MANUFACTURER.

MAINTENANCE FOR THE BF100 BAGEL FORMER ALWAYS BEGINS WITH KEEPING THE MACHINE CLEAN. PROPER CLEANING PROCEDURES CAN BE FOUND ON PAGE (8) OF THIS MANUAL. STANDARD LONG-TERM MAINTENANCE CONSISTS OF LUBRICATING MAIN WEAR POINTS OF THE MACHINE WITH AN ALL-PURPOSE LITHIUM BASE GREASE. A GREASE GUN WITH A FLEXIBLE HOSE IS NEEDED.

ALL RECOMMENDATIONS FOR MAINTENANCE, BASED ON A 7 DAY, 8 HR. PER DAY WORK SCHEDULE.

THE FIRST STEP OF NORMAL MAINTENANCE IS TO LOCATE THE GREASE FITTING ON THE FIRST OUTER FLANGE BEARING (PART #BDP10), (FIG. 1). WITH A GREASE GUN APPLY A SMALL AMOUNT OF GREASE TO THIS FITTING. THE SECOND BEARING IS SHROUDED BY THE CHAIN GUARD (PART # 104DR). THE GREASE FITTING ON THIS BEARING CAN BE LUBRICATED VIA THE ACCESS HOLE ON THE FRONT OF THE CHAIN GUARD. THESE PARTS SHOULD BE GREASED ONCE A WEEK.

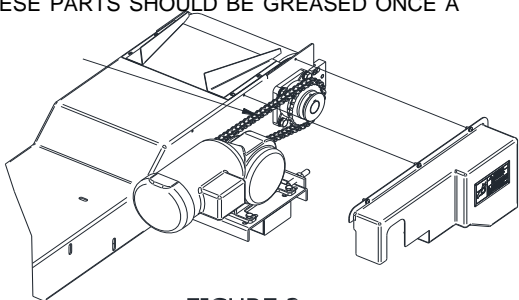

FIGURE 2

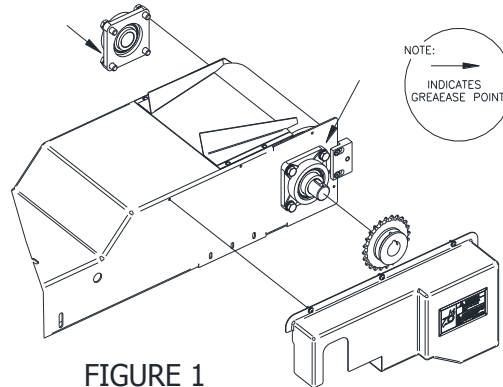

FIGURE 1

THE BF-100 BAGEL FORMER HAS A SINGLE DRIVE CHAIN (PART # 107DR). THIS PART MUST BE OILED REGULARLY WITH A LIGHT WEIGHT MACHINE OIL TO PROLONG LIFE OF THE SPROCKETS (PART #'S BDP12 / 106DR) AS WELL AS THE CHAIN. LOCATE THE OIL HOLE AT THE TOP OF THE CHAIN GUARD (PART #104DR). THOROUGHLY LUBRICATE THE CHAIN AT THIS POINT. NORMAL OPERATION OF THE FORMER AFTER THIS PROCEDURE, WILL DISTRIBUTE THE OIL OVER THE ENTIRE CHAIN AND SPROCKETS. THIS PROCEDURE MUST BE REPEATED ONCE A WEEK. NOTE: CHAIN CONDITION AND TENSION SHOULD BE CHECKED EVERY 60 DAYS. REMOVE CHAIN GUARD. INSPECT CHAIN AND MAKE NECESSARY ADJUSTMENTS. REPLACE CHAIN GUARD.

FOLLOW NORMAL CLEANING AND MAINTENANCE PROCEDURES OUTLINED IN THIS MANUAL. FOR ANY FURTHER ASSISTANCE CONTACT THE A.M. MFG. SERVICE DEPARTMENT @ (800) 342-6744. THESE INSTRUCTIONS WILL HELP YOU SERVICE THE UNIT. INSTRUCTIONS ARE FOR A PERSON WITH SOME MECHANICAL ABILITY AND TRAINING. NO ATTEMPT HAS BEEN MADE TO DESCRIBE ALL BASIC STEPS. FOR EXAMPLE, HOW TO LOOSEN OR TIGHTEN FASTENERS. ALSO, BASIC PROCEDURES LIKE HOW TO CYCLE SYSTEMS AND CHECK OPERATION OF EQUIPMENT ARE NOT DESCRIBED SINCE THEY ARE EXPECTED TO BE KNOWN TO ANYONE WHO PERFORMS MECHANICAL AND SERVICE WORK. DO NOT ATTEMPT TO PERFORM WORK BEYOND YOUR ABILITY OR AT WHICH YOU HAVE NO EXPERIENCE. IF YOU NEED ASSISTANCE CALL AN AUTHORIZED SERVICE CENTER OR CONTACT A.M. MANUFACTURING SERVICE DEPARTMENT @ (800) 342-6744

ASSEMBLY INSTRUCTIONS

THE BF-110 BAGELFORMER REQUIRES SOME ASSEMBLY BEFORE OPERATING. THE LEGS AND TABLES HAVE BEEN REMOVED FOR SHIPPING PURPOSES.

FAILURE TO ASSEMBLE PROPERLY COULD CAUSE PERSONAL INJURY OR PROPERTY DAMAGE.



CAUTION:

FOR SAFE ASSEMBLY, AT LEAST TWO PEOPLE ARE REQUIRED. SOME PARTS ARE HEAVY AND MAY CAUSE STRAIN AND INJURY IF ASSEMBLY IS ATTEMPTED BY JUST ONE PERSON.

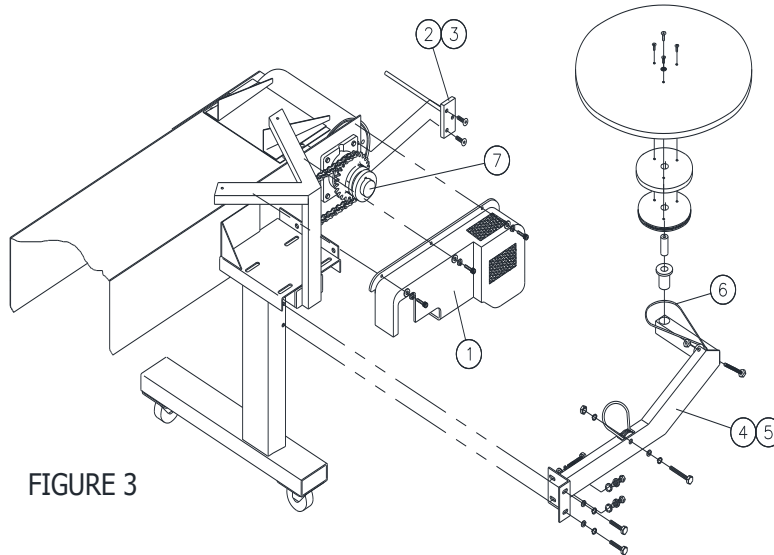

FIGURE 3

INSTRUCTIONS FOR TABLE ASSEMBLIES

1. REMOVE CHAIN GUARD (ITEM 1) AND TRIP BAR ASSEMBLY (ITEM 2 & 3).
2. LOCATE TABLE ARM AND HARDWARE (ITEMS 4 & 5).
 - HARDWARE KIT INCLUDES (2 ea.) F0604HH 3/8-18 x 1" Lg., (2 ea.) F0612FF 3/8-16 X 3" LG. HEX HEAD BOLTS, (4 ea.) F0600FW 3/8" FLAT WASHERS, (2 ea.) F0600LW 3/8" LOCK WASHERS AND (2 ea.) F0600NLN.
3. ENSURE ORANGE DRIVE BELT (ITEM 6) IS PROPERLY INSTALLED THROUGH TABLEARM. (ITEM 4) AS SHOWN IN **(FIG. 1)**.
4. PLACE ORANGE DRIVE BELT (ITEM 6) AROUND "V" GROOVE IN THE DRIVE SPROCKET (ITEM 7).
5. LOCATE THE BRONZE BUSHING ON THE ROTARY TABLE ARM (ITEM 4) AND INSERT THE SHAFT OF THE ROTARY TABLE ASSEMBLY THROUGH THE BUSHING, MAKING SURE THAT THE ORANGE DRIVE BELT (ITEM 6) IS LOOPED AROUND THE TABLE ASSEMBLY (AS SHOWN).
6. TAKE THE ORANGE DRIVE BELT (ITEM 6) AND PLACE IT INTO THE GROOVE ON THE ROTARY TABLE ASSEMBLY.
7. CHECK THE ORANGE BELT (ITEM 6) FOR TENSION AND TO MAKE SURE IT IS NOT RUBBING ON ANY SURFACE AND IS WRAPPED PROPERLY AROUND ALL PULLEYS (AS SHOWN) IN **(FIG. 1)**.
8. REINSTALL CHAIN GUARD (ITEM 1) AND TRIP BAR ASSEMBLY (ITEMS 2 & 3).



CAUTION:

IF TABLE DOES NOT ROTATE CHECK TO MAKE SURE BELT IS STRAIGHT. SEE ROTARY & STATIONARY TABLE ASSEMBLY FOR DETAILS AND PART NUMBERS.

FORMING BELT TIGHTENING PROCEDURES



WARNING:

BEFORE TIGHTENING BELT, BE CERTAIN THAT THE POWER SOURCE IS DISCONNECTED.

FOLLOW STEPS IN ORDER FOR PROPER BELT TENSION.

STEP 1: WITH 7/16" WRENCH, TIGHTEN OR LOOSEN HEX END OF STUD SHOWN IN FIGURE 1, PART NO.20918L & 20918R. TURN STUD COUNTER CLOCKWISE (TIGHTENS THE BELT) NO MORE THAN FIVE ROTATIONS BEFORE MAKING SAME ADJUSTMENT TO OPPOSITE SIDE. (MAKE SURE SWING PLATE IS INSTALLED PRIOR TO USING THIS ALTERNATING PATTERN TO LOOSEN BELT.)

STEP 2: RECONNECT POWER SOURCE AND START THE MACHINE. NOTE HOW THE BELT TRACKS. IF THE BELT TRACKS ON THE CENTER OF THE ROLLER, YOU ARE READY TO START PRODUCTION. IF NOT, DISCONNECT FROM POWER SOURCE AND REPEAT STEP 1, INSURING EQUAL ADJUSTMENT TO EACH SIDE.

STEP 3: TURN ON POWER TO BAGEL FORMER. CHECK TO SEE IF FORMING BELT IS TRACKING IN CENTER OF ROLLER.

STEP 4: IF BELT DRIFTS TO THE RIGHT OR LEFT SHUT OFF POWER AND UNPLUG MACHINE. REPEAT STEP 2, TIGHTENING THE SIDE THAT THE BELT IS TRACKING TO.

STEP 5: REPEAT STEPS 2-4 UNTIL BELT TRACKS IN THE CENTER OF THE IDLER ROLLER.

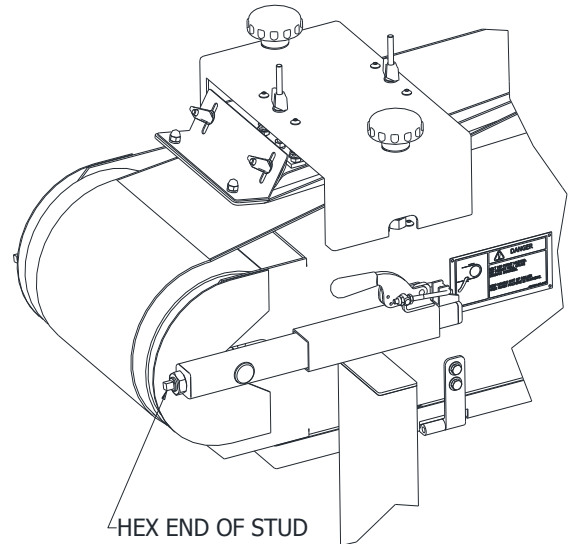

FIGURE 1



NOTE:

IF YOU HAVE ANY (?) QUESTIONS ABOUT GUARDS OR GUARD REPLACEMENT CALL 1- 800-342-6744.

CLEANING PROCEDURES

THESE PROCEDURES ARE VERY IMPORTANT TO MAINTAIN PRODUCT QUALITY AND MACHINE PERFORMANCE AND TO ASSURE SAFETY.

ALL A.M. MANUFACTURING MACHINE ARE TESTED WITH DOUGH DURING THE IN-HOUSE RUN-IN AND QUALITY AUDIT PROCEDURE. ALTHOUGH THE MACHINE HAS BEEN CLEANED, SOME EVIDENCE OF DOUGH ON AND IN THE MACHINE MAY BE DETECTED. THIS IS NORMAL. ALL PARTS IN CONTACT WITH DOUGH SHOULD BE WASHED THOROUGHLY AFTER USE, USING A MILD SOAP AND WATER SOLUTION. DISASSEMBLY OF THIS MACHINE FOR CLEANING IS OUTLINED BELOW AND ILLUSTRATED FOR YOUR CONVENIENCE.

1.  CAUTION: SHUT OFF ALL ELECTRICAL POWER.
2. LOOSEN FORMING BELT.
3. REMOVE PRESSURE PLATE ASSEMBLY, CLEAN AND REPLACE.
4. REMOVE FORMING TUBES, CLEAN AND REPLACE.
5. CAREFULLY LOWER BELT TENSIONING ROLLER, CLEAN AND REPLACE.
6. BRUSH EXCESS DOUGH FROM BELT SCRAPER.
7. REMOVE BAGEL BELT TO CLEAN & SCRAPE BOTH DRIVE AND IDLER ROLLERS, USING PLASTIC BENCH KNIFE.

 **NOTE:**

THE BAGEL FORMING BELTS SHOULD REMAIN LOOSE WHEN MACHINE IS NOT IN USE TO AVOID STRETCHING.

 **CAUTION:**

ALWAYS REMOVE BELTS FROM MACHINE FOR CLEANING.

 **NOTE:**

SEE ADJUSTMENT OF BAGEL BELT UNDER OPERATING INSTRUCTIONS ON PAGE (7) OF THIS MANUAL.

 **CAUTION:**

ALWAYS DISCONNECT ELECTRICAL SERVICE WHEN CLEANING OR MAINTAINING THIS MACHINE, THUS AVOIDING CHANCE OF SERIOUS INJURIES. MACHINES ARE NOT DANGEROUS IF COMMON SENSE IS APPLIED AND THE INSTRUCTIONS ARE CAREFULLY FOLLOWED. THINK AND PRACTICE SAFETY FIRST.

**THIS PAGE HAS BEEN
INTENTIONALLY LEFT BLANK**

IDLER ROLLER ASSEMBLY

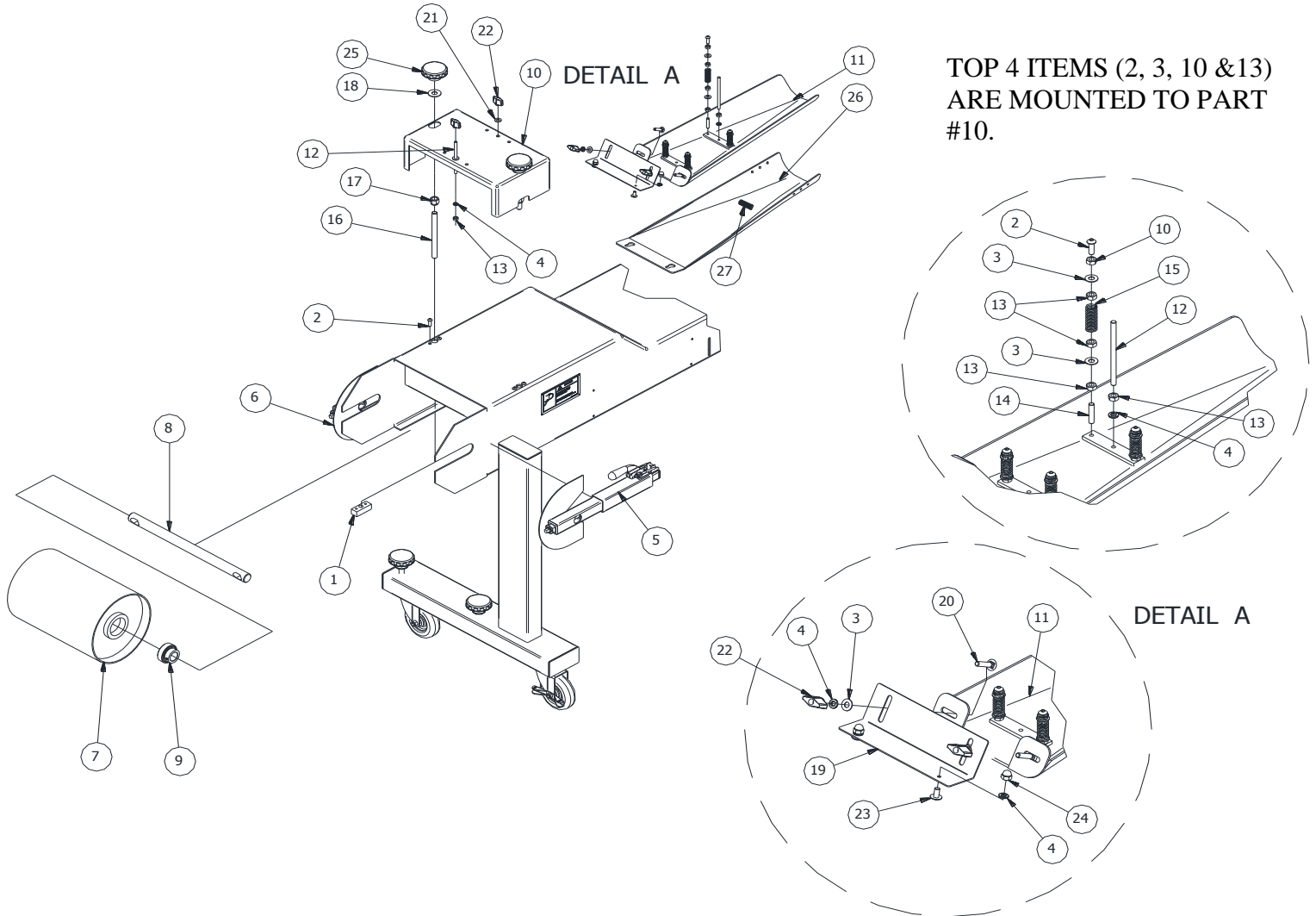

TOP 4 ITEMS (2, 3, 10 & 13)
ARE MOUNTED TO PART
#10.

DETAIL A

IDLER ROLLER ASSEMBLY

BILL OF MATERIAL

ITEM	PART NO	DESCRIPTION	QTY
1	655CA-14	ADJUSTING BLOCK	2
2	F0403SB	BUTTON HEAD, SOCKET 1/4-20 X 3/4" LG, S.S.	16
3	F0400FW	FLAT WASHER, 1/4"	55
4	F0400LW	LOCK WASHER, 1/4"	60
5	20918R	ROLLER TAKE-UP ASSEMBLY - RIGHT SIDE	1
6	20918L	ROLLER TAKE-UP ASSEMBLY - LEFT SIDE	1
7	100IR	ROLLER DRUM DRIVE PULLEY	1
8	101IR-A	TAKEUP ROLLER SHAFT	1
9	102IR	INSERT BEARING w/ LOCKING COLLAR	2
10	104IRA	PRESSURE PLATE BRIDGE	1
11	SFPP13	TOP PRESSURE PLATE ASSEMBLY WELDMENT	1
12	F0416SD	STUD, 1/4-20 X 4" LG, S.S.	2
13	F0400NC	NUT COURSE, 1/4-20	22
14	SFPP24	ADJUSTING SCREW	4
15	SFPP19	BAGEL FORMER	4
16	107IR	THREADED ROD, (PRESSURE PLATE)	2
17	F0800NLN	NUT-NYLOCK 1/2"	2
18	F0800NW	FLAT NYLON WASHER, 1/2"	4
19	SFPP18	DOUGH GUIDE	1
20	F0404CB	1/4-20 X 1" LONG CARRAIGE BOLT	2
21	F0400NW	NYLON FLAT WASHER 1/4"	2
22	F0400PWN	PLASTIC WING NUT (1/4-20)	4
23	F0402BH	BUTTON HEAD 1/4-20 X 1/2" LG.	2
24	F0400AN	ACORN NUT (1/4-20)	2
25	800PHK	PLASTIC KNOB (1/2-13)	2
26	SFPP12-1	PRESSURE PLATE FACING	1

FORMING MANDREL ASSEMBLY

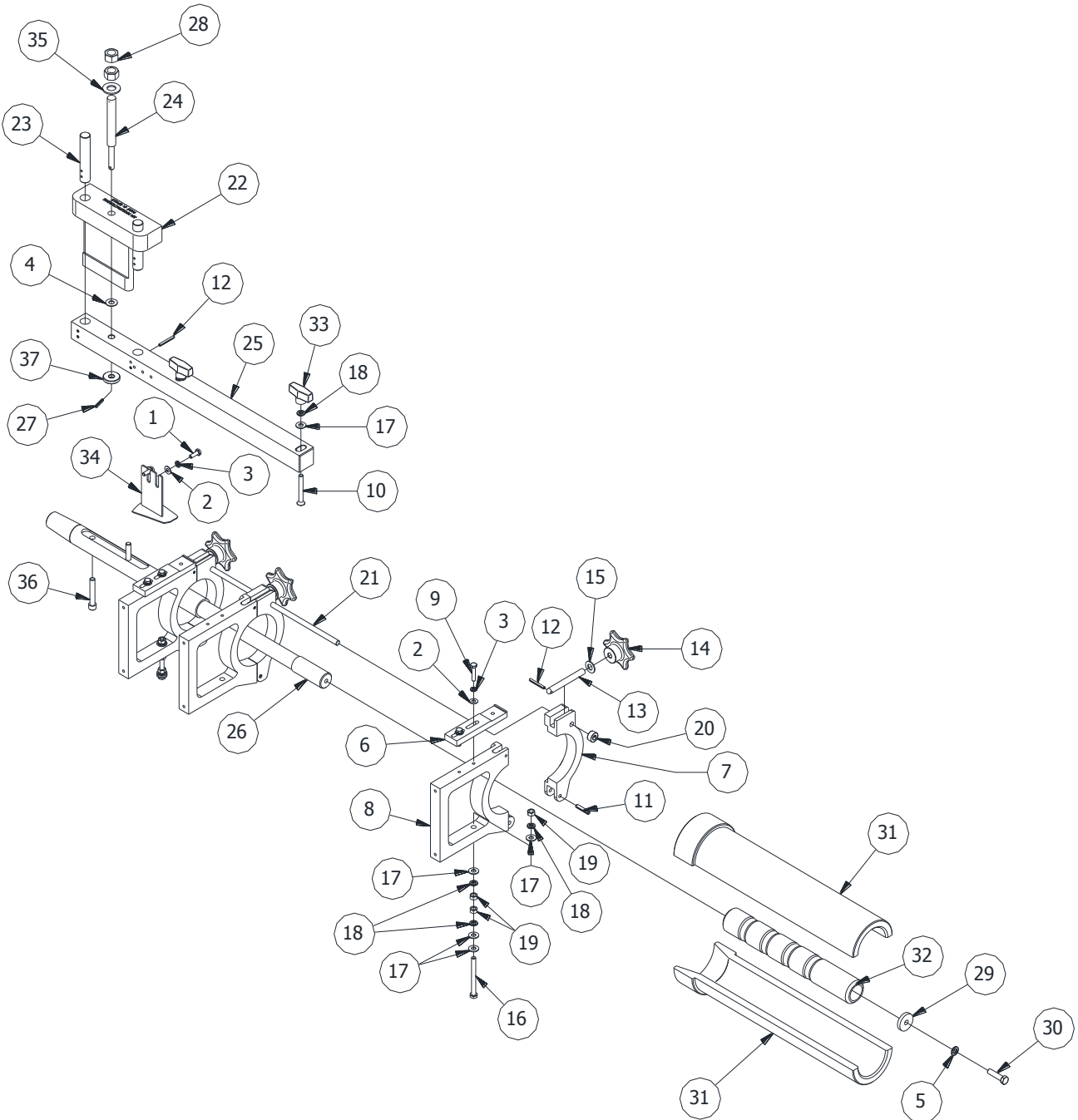

! NOTE:
ACTUAL DESIGN MAY VARY FROM THIS PICTURE

FORMING MANDREL ASSEMBLY

BILL OF MATERIAL

ITEM	PART NO	DESCRIPTION	QTY
1	F0403HHCS	HEX HEAD CAP SCREW 1/4-20 X 3/4"	22
2	F0400FW	FLAT WASHER, 1/4"	55
3	F0400LW	LOCK WASHER, 1/4"	60
4	F0600FW	FLAT WASHER 3/8"	20
5	F0600LW	LOCK WASHER 3/8"	15
6	BFM-4	HORIZONTAL ADJUSTING BLOCK	2
7	BFM31	CLAMP - FORMING TUBE	3
8	BFM-27	FORMING TUBE HOLDER	3
9	F0405HHCS	HEX HEAD CAP SCREW 1/4-20 X 1-1/4"	7
10	F0510FSH	FLAT SOCKET HEAD 5/16 X 2-1/2" LG.	2
11	F0405RP	1/4" X 1-1/4" LONG ROLL PIN (SPRING PIN)	3
12	F0306RP	3/16" DIA X 1-1/2" LONG ROLL PIN	7
13	BFM6	STUD-LOCKING HINGE	3
14	BFM19	STAR KNOB	3
15	F0700FW	FLAT WASHER 7/16"	3
16	F0513HHCS	HEX HEAD CAP SCREW 5/16-18 X 3-1/4"	2
17	F0500FW	FLAT WASHER, 5/16"	10
18	F0500LW	LOCK WASHER, 5/16"	8
19	F0500NC	NUT COURSE, 5/16-18	6
20	616CA	3/8" SHAFT COLLAR	4
21	N/A	3/8" S.S. ROUND STOCK X 13.75" LONG	1
22	BFM15	MANDREL SUPPORT & ADJUSTMENT (STANDARD AND DUAL BAGEL FORMERS)	1
23	BFM14	PIN-VERTICAL SLIDE	2
24	BFM-12	ADJUSTING SCREW-VERTICAL	1
25	BFM-2	MANDREL MOUNT BAR	1
26	BFM23	MANDREL BAR	1
	BFM37E	1-1/8" DIA. MANDREL - ADAPTER SUPPORT MINI SETS	
	BFM37F	1-1/4" DIA. MANDREL - ADAPTER SUPPORT	
27	F0304RP	3/16" DIA X 1" LONG ROLL PIN	1
28	F1000NC	NUT COURSE, 5/8-11	2
29	BFM33	WASHER	1
30	F0606HHCS	HEX HEAD CAP SCREW 3/8-16 X 1-1/2"	1
31	BFM21	FORMING TUBE (STANDARD #9) - 2.881 I.D.	1
	BFM54	5.0" FORMING TUBE SET	
	BFM40	6.0" FORMING TUBE SET MINI SETS	
	BFM50	7.0" FORMING TUBE SET	
	BFM51	8.0" FORMING TUBE SET	
32	BFM35	MANDREL SLEEVE (1.875)	1
	BFM34	1-1/2" DIA. MANDREL SLEEVE	
	BFM36	1-3/4" DIA. MANDREL SLEEVE MINI SETS	
	BFM37	2.0" DIA. MANDREL SLEEVE	
	BFM37A	2-1/8" DIA. MANDREL SLEEVE	
	BFM37B	2-1/4" DIA. MANDREL SLEEVE BULL SETS	
	BFM37C	2-3/8" DIA MANDREL SLEEVE	
33	F0500PWN	PLASTIC WING NUT (5/16-18)	2
34	BFM52L	DOUGH SHIELD	1
35	F1000FW	FLAT WASHER 5/8"	1
36	F0609SH	SCREW, SOCKET HEAD 3/8-16 X 2-1/4" LG	2
37	21375	SPACER	1

BFM1AS STANDARD COMPLETE BFM ASSEMBLY FROM MINI TO STANDARD SET-UP INCLUDES:

1-BFM MANDREL MOUNT BAR	1-BFM23 MANDREL ADAPTER SUPPORT
2-BFM14 VERTICAL SLIDE PIN	1-BFM12 VERTICAL ADJUSTING SCREW
1-BFM15 MANDREL SUPPORT	1-BFM21 FORM TUBE RIGHT- OUTER
ADJUSTING ASS. W/ 1-BFM16 VERTICAL PLATE	1-BFM24 FORM TUBE LEFT-INNER
2-BFM7 ROLL PIN	1-BDP21 STANDARD BAGEL CONV. W/BDP21 BELT 9" WIDE
2-BFM8 WASHER	1-BFM39 MANDREL BRIDGE
1-BFM35 MANDREL SLEEVE 1-7/8"	1-BFM11 HEX NUT
1-BFM32 BOLT	1-F0402HH BOLT
1-BFM33 WASHER	1-BFM52L DOUGH SHIELD
2-BFM20 SOCKET HEAD SCREW	2-F0402HH BOLT
1-BFM13 HEX NUT	2-F0400FW FLAT WASHER
1--F0204RP ROLL PIN	2-F0400LW LOCK WASHER
2-F0606SH BOLT	
1-F0602SS SET SCREW	

BFM2A STANDARD COMPLETE BFM ASSEMBLY FROM BULL TO STANDARD SET-UP INCLUDES:

BFM21 FORM TUBE RIGHT-OUTER
 1-BFM24 FORM TUBE LEFT-INNER
 1-BFM35 MANDREL SLEEVE 1-7/8"
 1-BDP21 STANDARD BAGEL CONV. W/ 9" BELT

BFM3A MINI SET-UP FROM STANDARD TO MINI SET-UP & FROM BULL TO MINI SET-UP INCLUDES:

1-BDP23 MINI BAGEL W/6" WIDE CON. BELT	1-BFM2 BAR MANDREL MOUNT
1-BFM40 MINI FORMING TUBE	1-BFM11 HEX NUT
1-BFM42 MANDREL & SUPPORT BAR 1-1/8"	1-BFN12 VERT. ADJUSTING SCREW W/BFM13 HEX NUT
1-BFM15 VERT. PLATE MANDREL SUPPORT ADJUSTING ASSEMBLY	2-BFM14 VERT. SLIDE PIN

BFM4A BULL SET-UP ASSEMBLY INCLUDES:

BFM41 FORMING TUBES	BFM37 MANDREL SLEEVE 2" DIA.
BDP22 BULL BAGEL CONV. BELT 10" WIDE	

DRIVE ROLLER ASSEMBLY

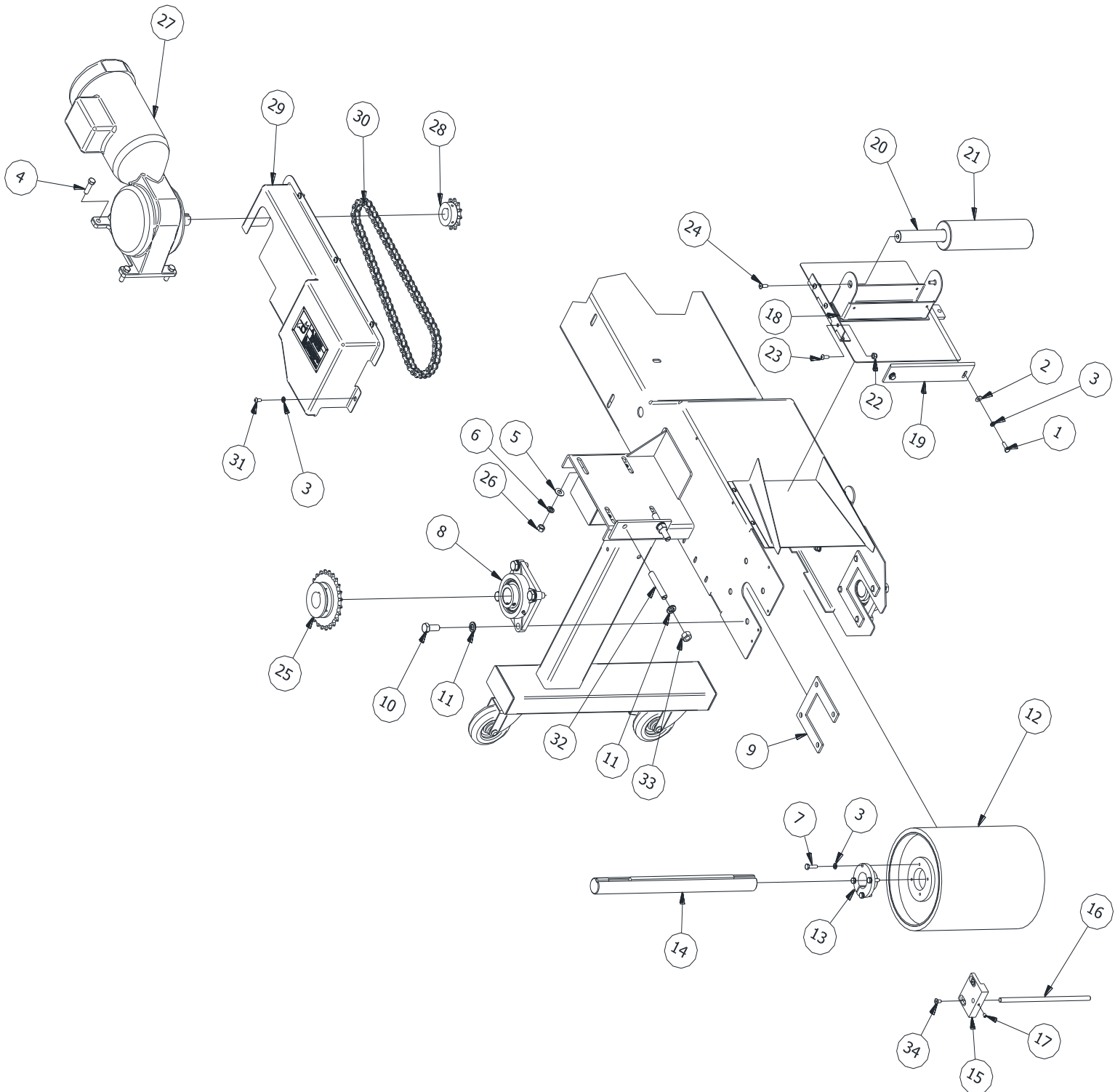

DRIVE ROLLER ASSEMBLY

BILL OF MATERIAL

ITEM	PART NO	DESCRIPTION	QTY
1	F0403HHCS	HEX HEAD CAP SCREW 1/4-20 X 3/4"	22
2	F0400FW	FLAT WASHER, 1/4"	56
3	F0400LW	LOCK WASHER, 1/4"	60
4	F0605HHCS	HEX HEAD CAP SCREW 3/8-16 X 1-1/4"	8
5	F0600FW	FLAT WASHER 3/8"	20
6	F0600LW	LOCK WASHER 3/8"	15
7	F0404HHCS	HEX HEAD CAP SCREW 1/4-20 X 1"	11
8	BDP10	4 HOLE FLANGE BEARING (1-3/8" SHAFT)	2
9	655CA-1A	BEARING MOUNT / SUPPORT	2
10	F0805HHCS	HEX HEAD CAP SCREW 1/2-13 X 1-1/4"	8
11	F0800LW	LOCK WASHER 1/2"	10
12	100DR	ROLLER DRUM DRIVE PULLEY	1
13	103DR	DRIVE PULLY XT BEARING	2
14	102DR	DRIVE ROLLER SHAFT	1
15	BFM148-005	TRIP BAR SUPPORT BLOCK	1
16	BFM148-017	TRIP BAR	1
17	F0401SS	SET SCREW, 1/4-20 X 1/4" LG	1
18	115DR-A	BELT TENSIONING SWING PLATE	1
19	111DR	ROLLER SCRAPER (BELT TENSION ASSY.)	1
20	116DR	BELT ROLLER SHAFT	1
21	110DR	BELT ROLLER	1
22	F0400NLN	NUT, NYLOCK 1/4"	9
23	F0402.5SB	BUTTON HEAD, SOCKET 1/4-20 X 5/8" LG, S.S.	3
24	F0403FSH	FLAT SOCKET HEAD 1/4-20 X 3/4" LG.	2
25	117DR	BAGEL FORMER DRIVE SPROCKET	1
26	F0600NC	NUT COURSE, 3/8	8
27	SS251	1 HP/ 68 RPM AC GEARMOTOR	1
28	106DR	MOTOR SPROCKET (50B12X1)	1
29	BFM148-002	CHAIN GUARD	1
30	N/A	ROLLER CHAIN	1
31	F0402SB	BUTTON HEAD, SOCKET 1/4-20 X 1/2" LG	4
32	108DR	1/2-13 BOLT	2
33	F0800NC	NUT COURSE, 1/2-13 NORMAL	2
34	F0402FSH	FLAT SOCKET HEAD SCREW, 1/4-20 X 1/2" LG.	2

TABLE ASSEMBLY

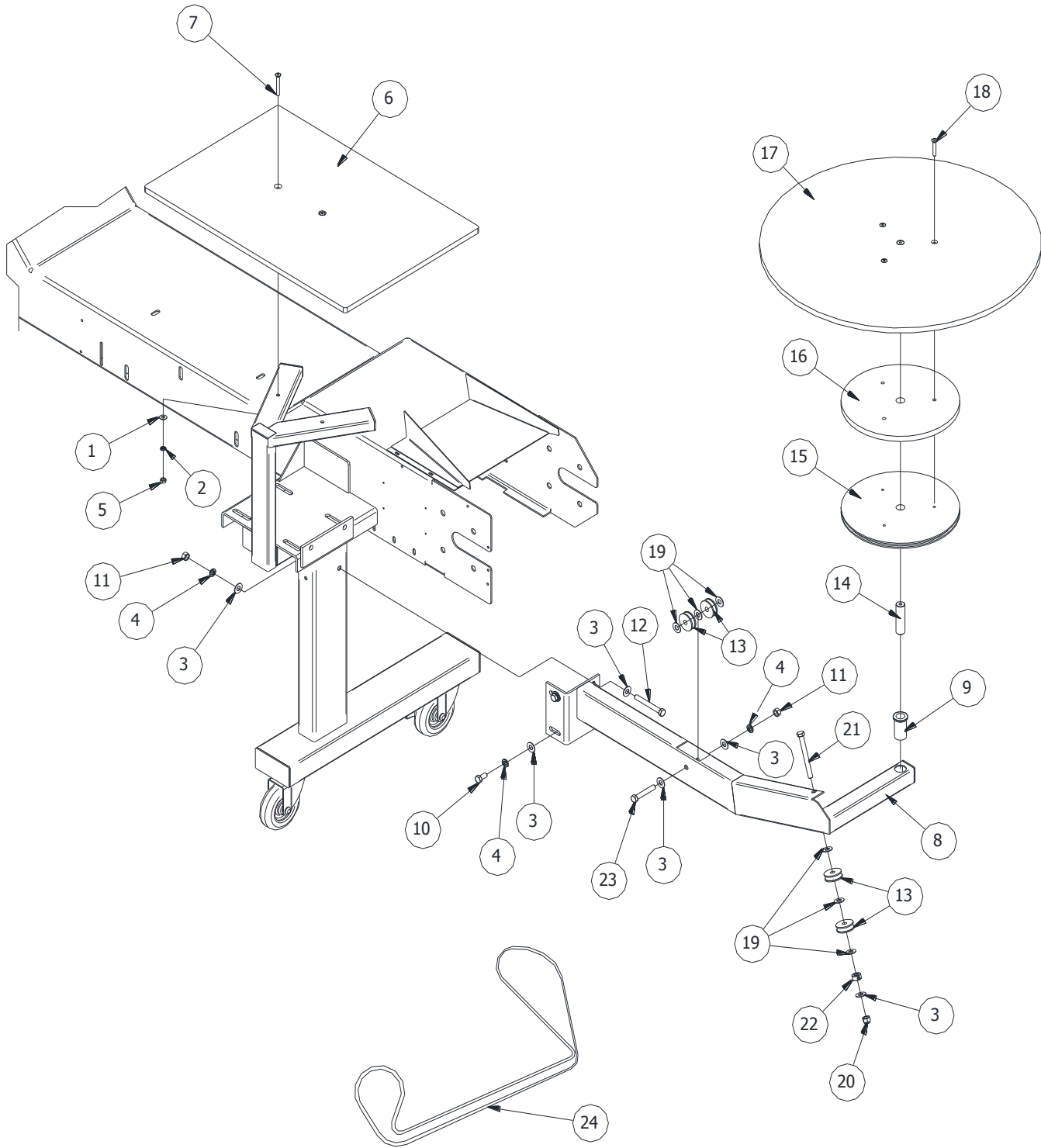
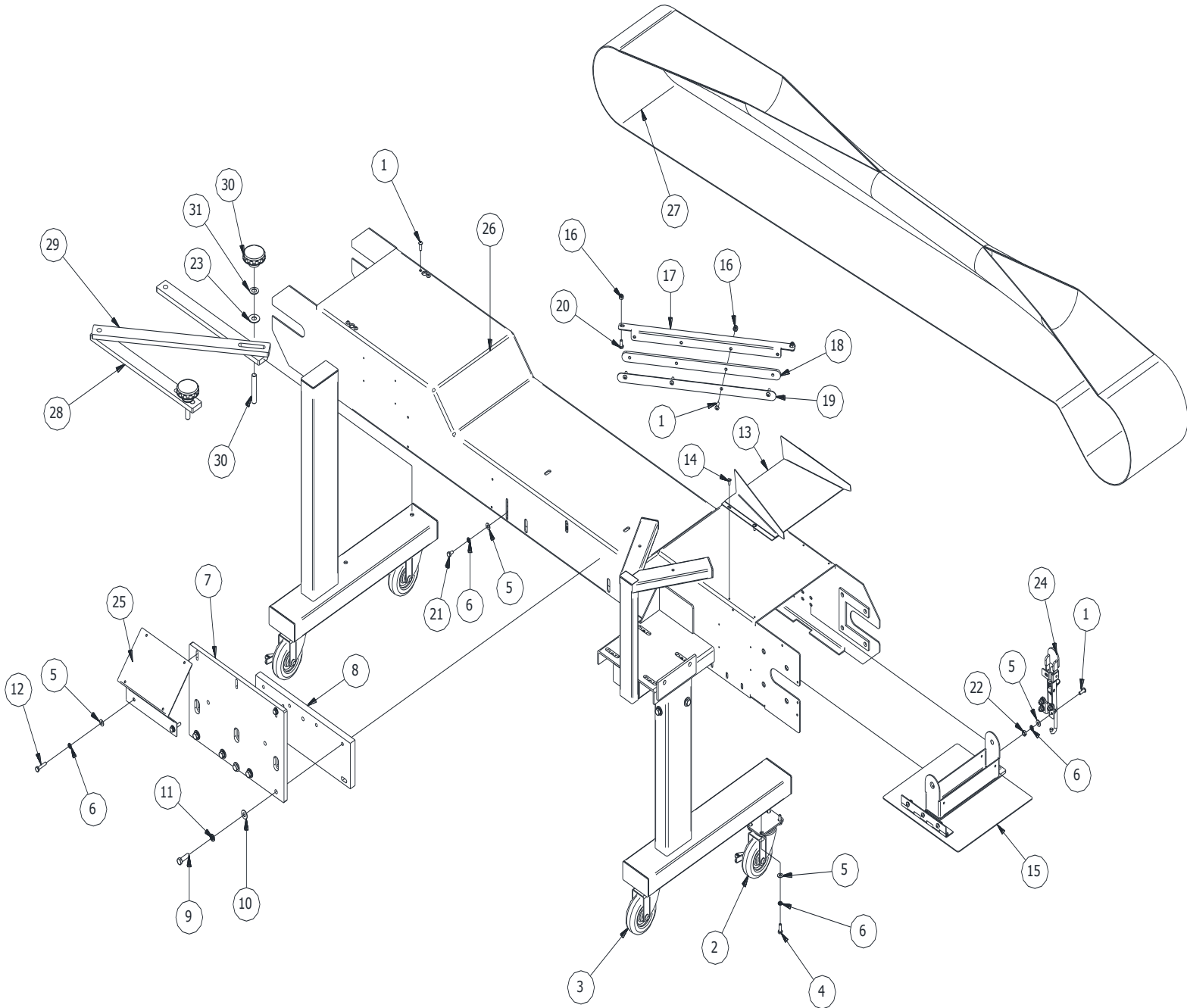

TABLE ASSEMBLY

BILL OF MATERIAL

ITEM	PART NO	DESCRIPTION	QTY
1	F0400FW	FLAT WASHER, 1/4"	52
2	F0400LW	LOCK WASHER, 1/4"	56
3	F0600FW	FLAT WASHER 3/8"	20
4	F0600LW	LOCK WASHER 3/8"	15
5	F0400NC	NUT COURSE, 1/4-20	20
6	BRT-11A	STATIONARY TABLE	1
7	F0408FSH	FLAT SOCKET HEAD, 1/4 X 2" LG.	2
8	BFM148-010	TABLE ARM ASSEMBLY	1
9	BFM148-016	BUSHING	1
10	F0603HHCS	HEX HEAD CAP SCREW 3/8-16 X 1"	2
11	F0600NC	NUT COURSE, 3/8	8
12	F0612HHCS	HEX HEAD CAP SCREW 3/8-16 X 3"	2
13	BFM148-072	TABLE ROLLER	4
14	BFM148-007	ROTATING TABLE SHAFT	1
15	BFM148-015	ROTATING TABLE FLANGE PULLEY	1
16	BFM148-014	ROTATING TABLE SPACER	1
17	BFM148-019	ROTATING TABLE	1
18	F0406FSH	FLAT SOCKET HEAD, 1/4 X 1-1/2" LG.	3
19	F0600NW	NYLON, FLAT WASHER 3/8"	6
20	F0600NLN	NUT-NYLOCK 3/8"	1
21	F0615HHCS	HEX HEAD CAP SCREW 3/8-16 X 3-3/4" LG	1
22	616CA	3/8" SHAFT COLLAR	3
23	F0609HHCS	HEX HEAD CAP SCREW 3/8-16 X 1/2"	1
24	BFM148-021	ORANGE DRIVE BELT	1

CABINET ASSEMBLY



CABINET ASSEMBLY

BILL OF MATERIAL

ITEM	PART NO	DESCRIPTION	QTY
1	F0403SB	BUTTON HEAD, SOCKET 1/4-20 X 3/4" LG, S.S.	16
2	621CA1	CASTER, LOCKING 4" DIA	2
3	621CA2	CASTER, SWIVEL 4" DIA	2
4	F0403HHCS	HEX HEAD CAP SCREW 1/4-20 X 3/4"	22
5	F0400FW	FLAT WASHER, 1/4"	56
6	F0400LW	LOCK WASHER, 1/4"	60
7	BFM3-1A	MANDREL EXTENSION PLATE	1
8	BFM3-2	MANDREL EXTESION SUPPORT PLATE	1
9	F0605HHCS	HEX HEAD CAP SCREW 3/8-16 X 1-1/4"	8
10	F0600FW	FLAT WASHER 3/8"	20
11	F0600LW	LOCK WASHER 3/8"	15
12	F0405HHCS	HEX HEAD CAP SCREW 1/4-20 X 1-1/4"	7
13	659CA	BELT GUIDE	1
14	F9902TH	10-32 X 1/2" LONG TRUSS HEAD	4
15	115DR-A	BELT TENSIONING SWING PLATE	1
16	F0400NLN	NUT, NYLOCK 1/4"	9
17	133RC	SCRAPER HOLDER ANGLE	1
18	152RC	SCRAPER	1
19	132RC	SCRAPPER	1
20	F0402.5HHCS	HEX HEAD CAP SCREW 1/4-20 X 5/8"	2
21	F0402HHCS	HEX HEAD CAP SCREW, 1/4-20 X 1/2" LG	2
22	F0400NC	NUT COURSE, 1/4-20	22
23	F0800NW	FLAT NYLON WASHER, 1/2"	4
24	12822	BELT TENSION SWING PLATE DESTACO CLAMP	1
25	21438	ELECTRICAL BOX DECK	1
26	655CA	BAGLE FORMER ASSEMBLY	1
27	BDP21	STANDARD BAGEL BELT	1
28	20937	DIVIDER / FORMER CONNECTION BAR (SHORT)	2
29	K622C	DIVIDER / FORMER CONNECTION BAR (LONG)	1
30	21449	MACHINE LOCK KNOB / STUD ASSEMBLY	2
31	F0800FW	FLAT WASHER 1/2"	2

ELECTRICAL LAYOUT

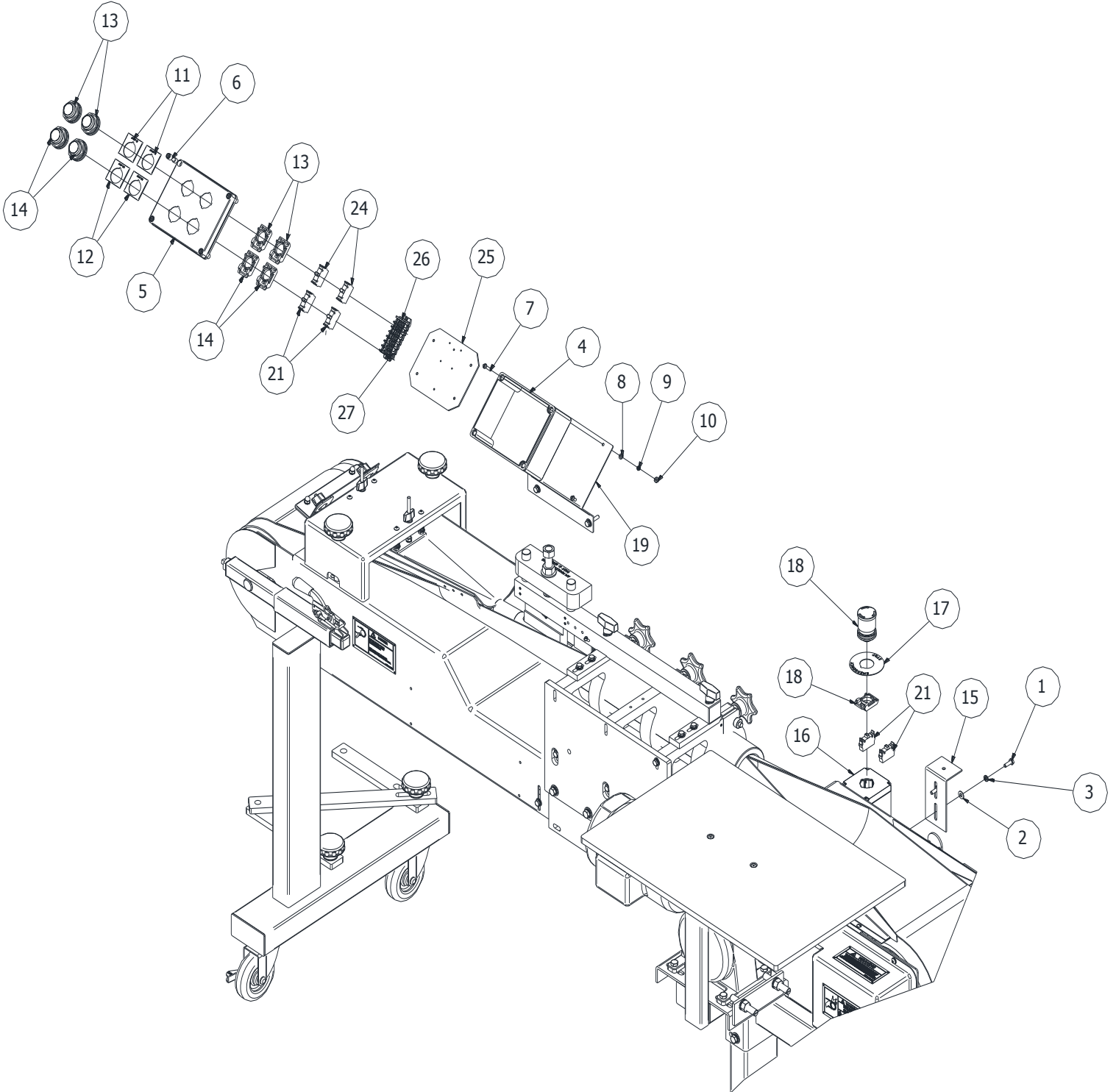

ELECTRICAL LAYOUT

BILL OF MATERIAL

ITEM	PART NO	DESCRIPTION	QTY
1	F0403HHCS	HEX HEAD CAP SCREW 1/4-20 X 3/4"	22
2	F0400FW	FLAT WASHER, 1/4"	56
3	F0400LW	LOCK WASHER, 1/4"	60
*4	SS279-1	ELECTRICAL CONTROL BOX - BOTTOM	1
*5	SS279-2	ELECTRICAL CONTROL BOX - TOP	1
*6	SS279-3	ELECTRICAL CONTROL BOX - SCREW	4
7	F9904PHS	Pan Head, Slotted, 10-32 UNF x 1" LG	4
8	F9900FW	FLAT WASHER, # 10	4
9	F9900LW	LOCK WASHER, #10	4
10	F9900MSN	10-32 MACHINE SCREW NUT	4
11	SS121	NAMEPLATE, "START (I)" - FOR 30mm PUSHBUTTON	2
12	SS122	NAMEPLATE, "STOP (O)" - FOR 30mm PUSHBUTTON	2
13	SS184	PUSH BUTTON, GREEN	2
14	EL-0409	PUSH BUTTON, RED	2
15	11877	GUARD BRACE #2	1
16	SS336	STOP BUTTON MOUNTING BOX	1
17	SS425	EMERGENCY STOP NAMEPLATE	1
18	SS185	PUSH BUTTON, RED	1
19	21438	CONTROL BOX MOUNT (PUSHBUTTON STATION)	1
20	400038	N.C. CONTACT BLOCK	4
21	400039	N.O. CONTACT BLOCK	2
22	662CA	ELECTRICAL PANEL	1
23	SS145	TERMINAL BLOCK END SEGMENT	1
24	SS144	TERMINAL BLOCK	7

*ITEMS #4, #5, & #6 ARE SOLD AS AN ASSEMBLY **ONLY**. SHOWN APART FOR CLARTY.

ORDERING REPLACEMENT PARTS

IMPORTANT:

ONLY USE FACTORY SUPPLIED REPLACEMENT PARTS TO MAINTAIN MACHINE SAFETY, PERFORMANCE AND SANITARY CONDITIONS.

USE OF NON-APPROVED PARTS MAY VOID MANUFACTURES WARRANTY.

TO ORDER REPLACEMENT PARTS ALWAYS:

- 1) CHECK THE MACHINE TO IDENTIFY MISSING, DAMAGED OR NON-FUNCTIONAL PARTS INCLUDING GUARDS, WARNING LABELS AND INSTRUCTIONS.
- 2) COMPARE THE LIST WITH THE PARTS DIAGRAMS SUPPLIED.
- 3) RECORD THE COMPLETE MODEL AND SERIAL NUMBER OF THE UNIT.
- 4) CALL A.M. MANUFACTURING (800) 342-6744 AND PROVIDE ALL INFORMATION NOTED ABOVE TO EXPEDITE ORDER PROCESSING AND HELP REDUCE SHIPPING COST.
- 5) PROVIDE COMPLETE DETAILS FOR (SHIP TO) AND (BILL TO) INFORMATION. TO ASSIST PROMPT DELIVERY, SPECIFY TYPE OF CARRIER PREFERRED IN SHIPMENT.

MOST MAJOR CREDIT CARDS ACCEPTED.

