

THE AM MANUFACTURING MODEL: R900T OPERATIONS & SAFETY MANUAL

INCLUDING PARTS CATALOG AND MAINTENANCE INSTRUCTIONS

PROJECT NUMBER: PRJ365
SHIP DATE: May 2008
AM Assembly #: _____
SERIAL #: _____



CAUTION:

DO NOT OPERATE, CLEAN, OR SERVICE THIS MACHINE BEFORE YOU READ THIS MANUAL AND ARE FAMILIAR WITH THE SAFETY INSTRUCTIONS IN THIS MANUAL AND THOSE ON THE LABELS ON THE MACHINE. KEEP THIS MANUAL AND OTHER MATERIALS DELIVERED WITH THE MACHINE, ACCESSIBLE TO THE OPERATORS FOR EASY REFERENCE DURING USE.

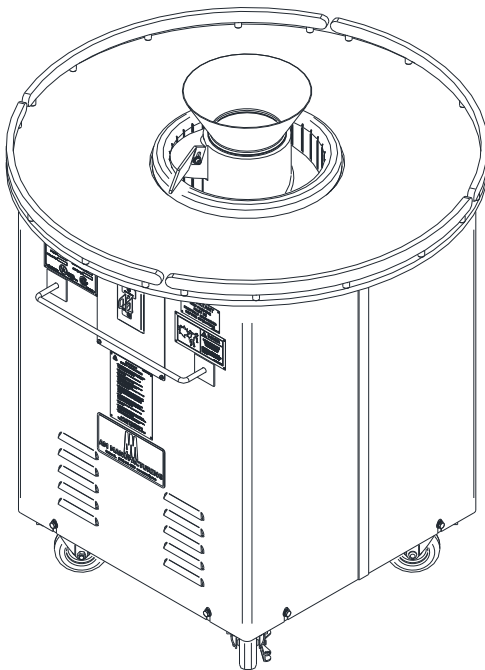

IF YOU SHOULD HAVE ANY (?)
QUESTIONS ABOUT GUARDS OR
PLACEMENT CALL (800) 342-6744.

THE ENTIRE CONTENTS OF THIS
PUBLICATION ARE COPYRIGHTED
AND ALL RIGHTS ARE RESERVED.
REPRODUCTION IN WHOLE OR IN
PART IS PROHIBITED WITHOUT
WRITTEN NOTICE PERMISSION OF
A.M. MFG. INC.



MANUFACTURING COMPANY

DIVISION OF THE ATWOOD CORPORATION
9200 CALUMET AVE. SUITE NW 07 MUNSTER, IN 46321
(219) 474-7272 (800) 342-6744 FAX: (219) 472-7271 www.ammfg.com

OWNERS RESPONSIBILITY

NOTE:

THE PARTS AND EQUIPMENT DESCRIBED IN THIS MANUAL MAY BE COVERED BY ONE OR MORE U.S. AND FOREIGN PENDING PATENTS.



TO MAINTAIN MACHINE AND USER SAFETY, THE RESPONSIBILITY OF THE OWNER IS TO READ AND FOLLOW THESE INSTRUCTIONS AND TO ENSURE THAT ALL OPERATORS UNDERSTAND AND FOLLOW THESE AND OTHER SAFETY INSTRUCTIONS IN THIS MANUAL.

- FOLLOW ALL INSTALLATION INSTRUCTIONS.
- MAKE SURE INSTALLATION CONFORMS TO ALL APPLICABLE LOCAL, STATE, AND FEDERAL CODES, RULES AND REGULATIONS SUCH AS STATE AND FEDERAL OSHA REGULATIONS AND ELECTRICAL CODES.
- CAREFULLY CHECK THE UNIT FOR CORRECT INITIAL FUNCTION.
- READ AND FOLLOW THE SAFETY INSTRUCTIONS. KEEP THEM READILY AVAILABLE FOR MACHINE OPERATORS.
- MAKE CERTAIN ALL OPERATORS ARE PROPERLY TRAINED AND THAT THEY KNOW HOW TO SAFELY AND CORRECTLY OPERATE THE UNIT AND ARE PROPERLY SUPERVISED.
- ALLOW UNIT OPERATION ONLY WITH ALL PARTS INCLUDING SAFETY EQUIPMENT, IN PLACE AND OPERATING SAFELY.
- CAREFULLY INSPECT THE UNIT ON A REGULAR BASIS AND PERFORM ALL MAINTENANCE AS REQUIRED.
- SERVICE AND MAINTAIN THE UNIT ONLY WITH AUTHORIZED OR APPROVED REPLACEMENT PARTS.
- KEEP ALL INSTRUCTIONS PERMANENTLY WITH THE UNIT ALONG WITH ALL DECALS AND WARNING LABELS ON THE UNIT CLEAN AND VISIBLE.

TABLE OF CONTENTS

CONTENTS	PAGE #
TRANSFER CONVEYOR LINE COVER PAGE.....	1
OWNERS RESPONSIBILITIES.....	2
TABLE OF CONTENTS.....	3
OPERATIONS AND SAFETY & INTRODUCTION & SPECIFICATIONS.....	4
SAFETY SIGNAL WORDS.....	5
WARNING LABELS.....	6
SAFTY RULES.....	7
OPERATING INSTRUCTIONS.....	8
CLEANING INSTRUCTIONS.....	9
GENERAL MAINTENANCE.....	10
BLANK PAGE.....	11
CABINET ASSEMBLY.....	12-13
ROUNDER ASSEMBLY.....	14-15
TABLE ASSEMBLY.....	16-17
ELECTRICAL COMPONENTS (SINGLE PHASE).....	18-19
ELECTRICAL COMPONENTS (THREE PHASE).....	20-21
ELECTRICAL SCHEMATIC.....	22-24
ORDERING REPLACEMENT PARTS.....	25
NOTES.....	26

IMPORTANT:

AMMANUFACTURING Co. RESERVES THE RIGHT TO MAKE CHANGES IN DESIGN, SPECIFICATIONS OR MANUFACTURING. TO IMPROVE THEIR PRODUCTS WITHOUT NOTICE AND WITHOUT OBLIGATION TO CHANGE OR IMPROVE PREVIOUSLY BUILT PRODUCTS, INCLUDING MANUALS AND CATALOGS.

ONLY USE FACTORY SUPPLIED REPLACEMENT PARTS TO MAINTAIN MACHINE SAFETY, PERFORMANCE AND SANITARY CONDITIONS. USE OF NON-APPROVED PARTS MAY VOID MANUFACTURERS WARRANTY.

KNOW YOUR UNIT. COMPARE DIAGRAMS IN THIS MANUAL WITH THE UNIT BEFORE STARTING SERVICE, TO OBTAIN MAXIMUM SAFETY AND PERFORMANCE.

TO ORDER REPLACEMENT PARTS:
TURN TO PAGE **25** OF THIS MANUAL.



WARNING:

THIS MANUAL CONTAINS CRITICAL SAFETY INSTRUCTIONS. READ AND FOLLOW THEM CAREFULLY. FAILURE TO FOLLOW WARNING AND INSTRUCTIONS MAY LEAD TO SERIOUS PERSONAL INJURY. THE OWNER IS RESPONSIBLE FOR MAINTAINING THE UNIT, ITS INSTRUCTIONS AND DECALS FOR OPERATION REFERENCE. FOR ADDITIONAL COPIES CONTACT AMMANUFACTURING: (800) 342-6744

OPERATIONS AND SAFETY MANUAL

INCLUDING PARTS CATALOG

READ AND FAMILIARIZE YOURSELF WITH THIS MANUAL BEFORE OPERATING THIS MACHINE
FOLLOW INSTRUCTIONS DURING USE

INTRODUCTION

YOUR R900T DOUGH ROUNDER HAS BEEN BUILT WITH THE BUSY BAKER IN MIND. IT'S VERSATILITY AND SIMPLICITY ARE UNMATCHED IN THE INDUSTRY. PRODUCTION DEPENDS ON THE DESIRED DOUGH BALL SIZE AND HOW FAST THE DIVIDED DOUGH PIECES ARE DROPPED INTO THE FUNNEL. SMALL PIECES CAN BE FED APPROXIMATELY TWO PER SECOND, WHEREAS LARGER DOUGH PIECES (UP TO 2 lbs.) MUST BE FEED AT A LESSER RATE. GETTING THE FEEL OF THE MACHINE WILL BEST DETERMINE JUST WHAT THE FEED RATE SHOULD BE FOR ANY CERTAIN DOUGH BALL SIZE. NO ADJUSTMENTS ARE NECESSARY WHEN CHANGING THE SIZE OF YOUR DOUGH PIECE, IT WILL AUTOMATICALLY BE ROUNDED INTO A TIGHT, SMOOTH BALL, WITH NO MORE EFFORT THAN IT TAKES TO DROP THEM INTO THE FUNNEL.



CAUTION:

ALL OPERATORS MUST BE FULLY TRAINED AND INSTRUCTED IN SAFETY PROCEDURES BEFORE BEGINNING PRODUCTION.

SPECIFICATIONS

R900-C

CONVEYOR LENGTH	18 1/2" FROM FRONT OF MACHINE. (23" OVERALL LENGTH)
CONVEYOR BELT	2 PLY PVC
OVERALL HEIGHT	42 1/2"
MACHINE WIDTH	24"
HEIGHT UNDER CONVEYOR	32 3/4"
VOLTAGE (STANDARD)	115 VOLT SINGLE PHASE
VOLTAGE (OPTIONAL)	208/220 (3) PHASE
AMPERAGE	15 AMPS.
PRODUCTION RANGE	1 oz. TO 2 1/2 lbs.
PRODUCTION RATE	UP TO 7200 PIECES PER HOUR
SHIPPING WEIGHT	350 lbs.

R900-T

TABLE DIAMETER	35 1/2"
MACHINE WIDTH	24"
OVERALL HEIGHT	42 1/2"
HEIGHT UNDER TABLE	36 1/4"
VOLTAGE (STANDARD)	115 VOLT SINGLE PHASE
VOLTAGE (OPTIONAL)	208/220 (3) PHASE
AMPERAGE	15 AMPS.
PRODUCTION RANGE	1 oz. TO 2 1/2 lbs.
PRODUCTION RATE	UP TO 7200 PIECES PER HOUR
SHIPPING WEIGHT	350 lbs.

INSTALLATION INSTRUCTIONS LOCATION

SELECT LOCATION CAREFULLY. THE AREA SHOULD PROVIDE THE OPERATOR WITH ENOUGH SPACE TO USE THE EQUIPMENT IN A SAFE MANNER. THE FLOOR AREA SELECTED SHOULD BE A FLAT SURFACE AND EASY TO CLEAN AND SHOULD BE FREE OF OIL, GREASE, ECT. AVOID AREAS WHERE BYSTANDERS AND CUSTOMERS MAY BE PRESENT.



CAUTION:

PROPER UNIT INSTALLATION IS NECESSARY FOR SAFE AND EFFICIENT OPERATION. PROPER INSTALLATION ALSO HELPS PROTECT THE UNIT FROM DAMAGE AND MAKES SERVICE EASIER.

SAFETY SIGNAL WORDS

THIS MACHINE IS DESIGNED TO PROVIDE FOR SAFE OPERATION IF NORMAL OPERATING PROCEDURES AND SAFETY MESSAGES LOCATED ON THE MACHINE AND IN THIS MANUAL ARE FOLLOWED.



THIS IS A SAFETY ALERT SYMBOL. YOU WILL FIND IT ON VARIOUS SAFETY LABELS ON THE MACHINE AND IT WILL ALSO APPEAR IN THIS MANUAL WHEREVER SAFETY MESSAGES ARE GIVEN.

GET FAMILIAR WITH SIGNAL WORDS:

CAUTION, WARNING & DANGER

CAUTION:

INDICATES A POTENTIALLY HAZARDOUS SITUATION WHICH, IF NOT AVOIDED, MAY RESULT IN MINOR OR MODERATE INJURY. IT MAY ALSO BE USED TO ALERT AGAINST UNSAFE PRACTICES.

WARNING:

INDICATES A POTENTIALLY HAZARDOUS SITUATION WHICH, IF NOT AVOIDED, COULD RESULT IN DEATH OR SERIOUS INJURY.

DANGER:

INDICATES AN IMMINENTLY HAZARDOUS SITUATION WHICH, IF NOT AVOIDED, WILL RESULT IN DEATH OR SERIOUS INJURY. THIS SIGNAL WORD IS TO BE LIMITED TO THE MOST EXTREME SITUATIONS.

NOTE:

A NOTE PROVIDES KEY INFORMATION TO MAKE PROCEDURES EASIER AND CLEARER.

WARNING LABELS TYPICALLY FOUND ON THE R900T

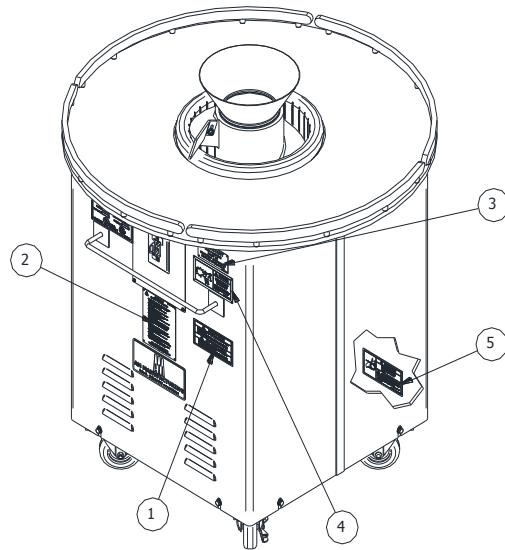

① AMTAG160SF: TOP OF CABINET

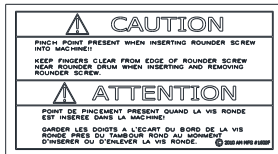

③ TAG5M: UPPER RIGHT CORNER CABINET



④ AMTAG10AMF: UPPER RIGHT CORNER CABINET

AMTAG10ASF: INSIDE CABINET ON ELECTRICAL BOX

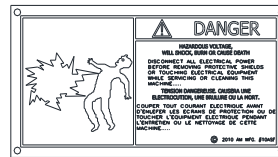

② TAG21M: BELOW ELECTRICAL SWITCH PLATE

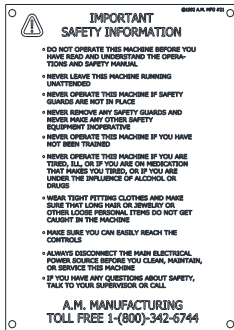

⑤ AMTAG24SF: INSIDE CABINET NEAR CHAIN

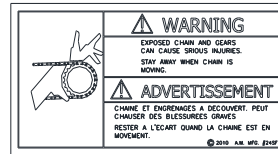

NOTE:
 MACHINE DESIGN AND SPECIFICATIONS MAY VARY. ACTUAL LABEL DESIGN AND PLACEMENT SUBJECT TO CHANGE WITHOUT NOTICE AND MAY VARY FROM THIS ILLUSTRATION.



CAUTION:
 IF ANY SAFETY LABELS ARE MISSING THEY **MUST BE** REPLACED!
 CONTACT YOUR DEALER OR A.M. MFG. FOR REPLACEMENT.

SAFETY RULES



IMPORTANT:

READ AND FOLLOW THESE SAFETY RULES. THEY ARE FOR YOUR PROTECTION AND THE PROTECTION OF THOSE WORKING WITH YOU.

- **DO NOT** OPERATE THIS MACHINE BEFORE YOU HAVE READ AND UNDERSTOOD THE OPERATIONS AND SAFETY MANUAL.
- FOLLOW ALL INSTRUCTIONS DURING USE OF THIS MACHINE.
- LEAVE ALL GUARDS IN PLACE. INSTALL ALL GUARDS IF THEY WERE REMOVED FOR CLEANING, MAINTENANCE, REPAIR OR OTHER REASONS.
- **NEVER** OPERATE THE MACHINE IF YOU HAVE NOT BEEN TRAINED TO OPERATE THE MACHINE PROPERLY.
- **NEVER** OPERATE THE MACHINE IF YOU ARE TIRED, ILL, ON MEDICATION, OR UNDER THE INFLUENCE OF ALCOHOL OR DRUGS.
- WEAR TIGHT FITTING CLOTHES. MAKE SURE THAT LONG HAIR, JEWELRY, OR LOOSE PERSONAL ITEMS ARE SECURED SO THEY CANNOT GET CAUGHT IN THE MACHINE. THIS CAN LEAD TO SERIOUS INJURIES.
- MAKE SURE YOU CAN EASILY REACH ALL CONTROLS. IF NOT, A STABLE AND SAFE ELEVATED PLATFORM OR OTHER WORK-AID MUST BE PROVIDED.
- **ALWAYS** DISCONNECT THE MAIN ELECTRICAL POWER SOURCE AND TURN MACHINE SWITCH TO THE OFF POSITION BEFORE CLEANING, IF MAINTENANCE OR SERVICE IS PERFORMED, OR IF THE MACHINE IS OUT OF SERVICE.
- **NEVER** LEAVE THIS MACHINE RUNNING UNATTENDED.

IMPORTANT:

IF YOU HAVE ANY QUESTIONS ABOUT THESE SAFETY RULES, SEE YOUR SUPERVISOR OR CALL AM MANUFACTURING Co. TOLL FREE: (800) 342-6744

OPERATING INSTRUCTIONS



WARNING:

UNIT MUST BE PROPERLY OPERATED AND MAINTAINED TO PREVENT MACHINE DAMAGE OR PERSONAL INJURY. REVIEW INSTRUCTIONS WITH ALL EMPLOYEES BEFORE USE.

I. PRELIMINARY START - UP PROCEDURE

- A. BE SURE DRUM, TABLE AND CONVEYOR ARE CLEAR OF PACKING, PACKING SLIPS, DOCUMENTS AND OTHER OBSTRUCTIONS.
- B. MAKE SURE THE MACHINE SWITCH IS IN THE **OFF** POSITION.
- C. LOWER DISCHARGE CONVEYOR (FOR **R900C** MODELS **ONLY**) TO OPERATION POSITION.
- D. PLUG POWER CORD INTO PROPER RECEPTACLE.
- E. SWITCH MACHINE TO THE "ON" POSITION.
- F. THE ROUNDING DRUM SHOULD BE TURNING IN A COUNTER CLOCK-WISE ROTATION.
- G. THE ROUNDER TABLE SHOULD BE TURNING IN A COUNTER CLOCK-WISE ROTATION, / THE DISCHARGE CONVEYOR SHOULD BE RUNNING FORWARD OUT FROM MACHINE. ALL THIS DEPENDING ON THE MODEL OF ROUND - O - MATIC YOU HAVE PURCHASED. (**NOTE**) **NEVER** OPERATE THE MACHINE WITH THE DISCHARGE CONVEYOR IN THE UPRIGHT POSITION.

NOTE:

IF THE MACHINE YOU HAVE PURCHASED IS A (3) PHASE MACHINE AND THE ROTATION OF THE ROUNDING DRUM IS NOT CORRECT, CONSULT A PROPERLY TRAINED ELECTRICIAN

II. OPERATING THE R900T

- A. THE R900T TABLE OR CONVEYOR MODEL IS READY TO ROUND AFTER:
- B. POSITION R900T IN THE DESIRED LOCATION AND SET THE TWO (2) LOCKING CASTERS.
- C. PLUG THE POWER CORD INTO PROPER RECEPTACLE.
- D. CHECK FOR PROPER ROTATION OF ROUNDING DRUM, REFER TO PRELIMINARY START - UP PROCEDURE.
- E. TO ROUND SIMPLY DROP DOUGH PIECES (1oz. TO 2 lbs.) INTO FUNNEL. THE DOUGH WILL AUTOMATICALLY BE ROUNDED AND THEN DEPOSITED ONTO THE TABLE OR CONVEYOR FOR PANNING.

CAUTION:

DO NOT ATTEMPT TO OPERATE THIS MACHINE WITHOUT READING THE MANUAL. ALWAYS HAVE THE TABLE OR TOP COVER IN PLACE!

CLEANING INSTRUCTIONS

ALL AM MANUFACTURING MACHINES ARE TESTED WITH DOUGH DURING THE IN - HOUSE, RUN - IN AND QUALITY AUDIT PROCEDURE. ALTHOUGH THE MACHINE HAS BEEN CLEANED, SOME EVIDENCE OF DOUGH ON AND IN THE MACHINE MAY BE DETECTED, THIS IS NORMAL.

ALL PARTS IN CONTACT WITH DOUGH SHOULD BE WASHED THOROUGHLY AFTER USE, USING A MILD SOAP AND WATER SOLUTION. DISASSEMBLY OF THIS MACHINE FOR CLEANING IS OUTLINED AND ILLUSTRATED FOR YOUR CONVENIENCE.

INSTRUCTIONS IN THIS MANUAL INDICATE THE NEED FOR REGULAR INSPECTION AND CLEANING TO PREVENT INFESTATION.

- A. CAUTION: SHUT OFF ALL ELECTRICAL POWER, AND UNPLUG POWER CORD.
- B. REMOVE ROUNDER TABLE (PART NO. R211TA) BY LIFTING STRAIGHT UP (IF APPLICABLE).
- C. REMOVE FUNNEL. (PART NO. R116RA).
- D. REMOVE ROUNDER SCREW, USING TWO PEOPLE TO LIFT ROUNDER SCREW (PART NO. R122RA).
- E. REMOVE DRUM (PART NO. R117RA).
- F. REMOVE PLASTIC SEAL RING (PART NO. R141RA).
- G. REMOVE EXCESS DOUGH FROM ROUNDER BASE.
- H. REASSEMBLE IS IN REVERSE OS DISASSEMBLE OF STEP 1 THRU 8.
- I. MAKE SURE TO REPLACE PLASTIC SEAL RING.
- J. SLIP THE DRUM OVER THE ROUNDER BASE SO THAT THE DRIVE SLOTS ARE LOCKED OVER THE DRIVE PINS IN THE ROUNDER BASE.
- K. CARE SHOULD BE TAKEN TO SEE THAT THE EXIT RAMP ON THE SCREW IS APPROXIMATELY OPPOSITE THE ON / OFF SWITCH AFTER THE SCREW HAS DROPPED INTO PLACE.
- L. ON TABLE MODELS, BE SURE THAT THE RING GEAR (MOUNTED ON THE UNDER SIDE OF THE TABLE) IS ENGAGED OVER ALL FOUR (4) BEARINGS AND MESHED WITH THE DRIVE GEAR. WHEN PROPERLY ENGAGED, THE TABLE WILL SIT FIRM AND LEVEL AROUND THE DRUM. KEEP FINGERS AWAY FROM UNDERNEATH ROTATING TABLE DURING OPERATION.

NOTE:

PARTS SUCH AS THE ROUNDER SCREW AND DRUM SHOULD BE HANDLED WITH EXTREME CARE; WHEN CLEANING THE ROUNDER DRUM THE WATER TEMPERATURE MUST NOT EXCEED 190°.

IF UNABLE TO REMOVE ROUNDER SCREW: **NEVER** PUT HANDS OR ARMS INTO ROUNDER SCREW.

- A. PLUG MACHINE IN. TURN MACHINE ON.
- B. ADD A SMALL AMOUNT OF WARM WATER TO CONTACT AREA BETWEEN SCREW AND DRUM.
- C. AFTER DOUGH SOFTENS, TURN OFF ROUNDER
- D. UNPLUG MACHINE.
- E. REMOVE ROUNDER SCREW. USING TWO PEOPLE TO LIFT ROUNDER SCREW.



PRACTICE SAFETY FIRST

ALWAYS DISCONNECT ELECTRICAL SERVICE AND TURN MACHINE SWITCH TO THE OFF POSITION BEFORE CLEANING OR MAINTAINING THIS MACHINE, THUS AVOIDING CHANCE OF SERIOUS INJURIES. MACHINES ARE NOT DANGEROUS IF COMMON SENSE IS APPLIED AND THE INSTRUCTIONS ARE FOLLOWED. THINK AND PRACTICE SAFETY FIRST.

GUIDE TO GENERAL MAINTENANCE

READ AND FOLLOW MAINTENANCE INSTRUCTIONS BELOW TO HELP KEEP THE UNIT IN GOOD OPERATING CONDITION. REFER TO OTHER MATERIALS RECEIVED WITH THE UNIT AND TO SERVICE BULLETINS FROM THE MANUFACTURER FOR ADDITIONAL INSTRUCTIONS FOR PROPER MAINTENANCE AND SERVICE. REGULAR INSPECTIONS AND PROPER MAINTENANCE ARE ESSENTIAL TO HELP PREVENT ACCIDENTS AND INJURIES.



PRACTICE SAFETY FIRST:

ALWAYS DISCONNECT ELECTRICAL SERVICE AND TURN MACHINE SWITCH TO THE OFF POSITION BEFORE CLEANING OR MAINTAINING THIS MACHINE, THUS AVOIDING CHANCE OF SERIOUS INJURIES. MACHINES ARE NOT DANGEROUS IF COMMON SENSE IS APPLIED AND THE INSTRUCTIONS ARE CAREFULLY FOLLOWED. THINK AND PRACTICE SAFETY FIRST...



WARNING:

BEFORE MAKING ANY INSPECTION, ADJUSTMENT OR REPAIR, BE CERTAIN POWER SOURCE IS DISCONNECTED AND THE MACHINE SWITCH IS IN THE OFF POSITION WITH ALL MOVING PARTS BEING BLOCKED OUT TO PREVENT INJURY. WEAR PROTECTIVE CLOTHING.

- A. THE TABLE TOP AND OTHER WORKING SURFACES SHOULD BE CLEANED REGULARLY.
- B. MAKE SURE THAT ALL FASTENERS ARE TIGHTENED SECURELY.
- C. MAKE CERTAIN THAT ALL GUARDS AND COVERS ARE IN PLACE.
- D. CHECK FOR WORN, DAMAGED OR MISSING PARTS INCLUDING BELTS, SAFETY GUARDS AND PROTECTIVE COVERS.
- E. ON A DAILY BASIS, INSPECT THE UNIT AND CHECK TO BE CERTAIN THAT ALL SYSTEMS ARE OPERATING NORMALLY. DETAILED INSPECTION AND TESTING PROCEDURES ARE SPECIFIED FOR VARIOUS COMPONENTS AT REGULAR INTERVALS. SET UP A CHART AND ASSIGN RESPONSIBILITY FOR THESE ITEMS.



CAUTION:

REPLACE ANY DAMAGED OR MISSING SAFETY LABELS. THEY ARE AVAILABLE FROM THE MANUFACTURER.

MAINTENANCE FOR THE R900T ALWAYS BEGINS WITH KEEPING THE MACHINE CLEAN. PROPER CLEANING PROCEDURES CAN BE FOUND ON PAGE (6) OF THIS MANUAL. STANDARD LONG TERM MAINTENANCE CONSISTS OF LUBRICATING MAIN WEAR POINTS.

ALL RECOMMENDATIONS FOR MAINTENANCE ARE BASED ON A 7 DAY, 8 HOUR PER DAY WORK SCHEDULE.

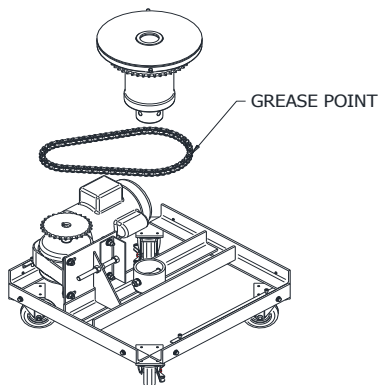

THE R900T HAS A SINGLE DRIVE CHAIN (PART NO. R105RA). THIS PART MUST BE OILED REGULARLY WITH A LIGHT MACHINE OIL TO PROLONG LIFE OF THE SPROCKETS, AS WELL AS THE CHAIN.

AGAIN, CHAIN CONDITION AND TENSION SHOULD BE CHECKED EVERY 60 DAYS OR MORE FREQUENTLY IF EXCESS NOISE OR VIBRATION IS NOTED.

CABINET ASSEMBLY

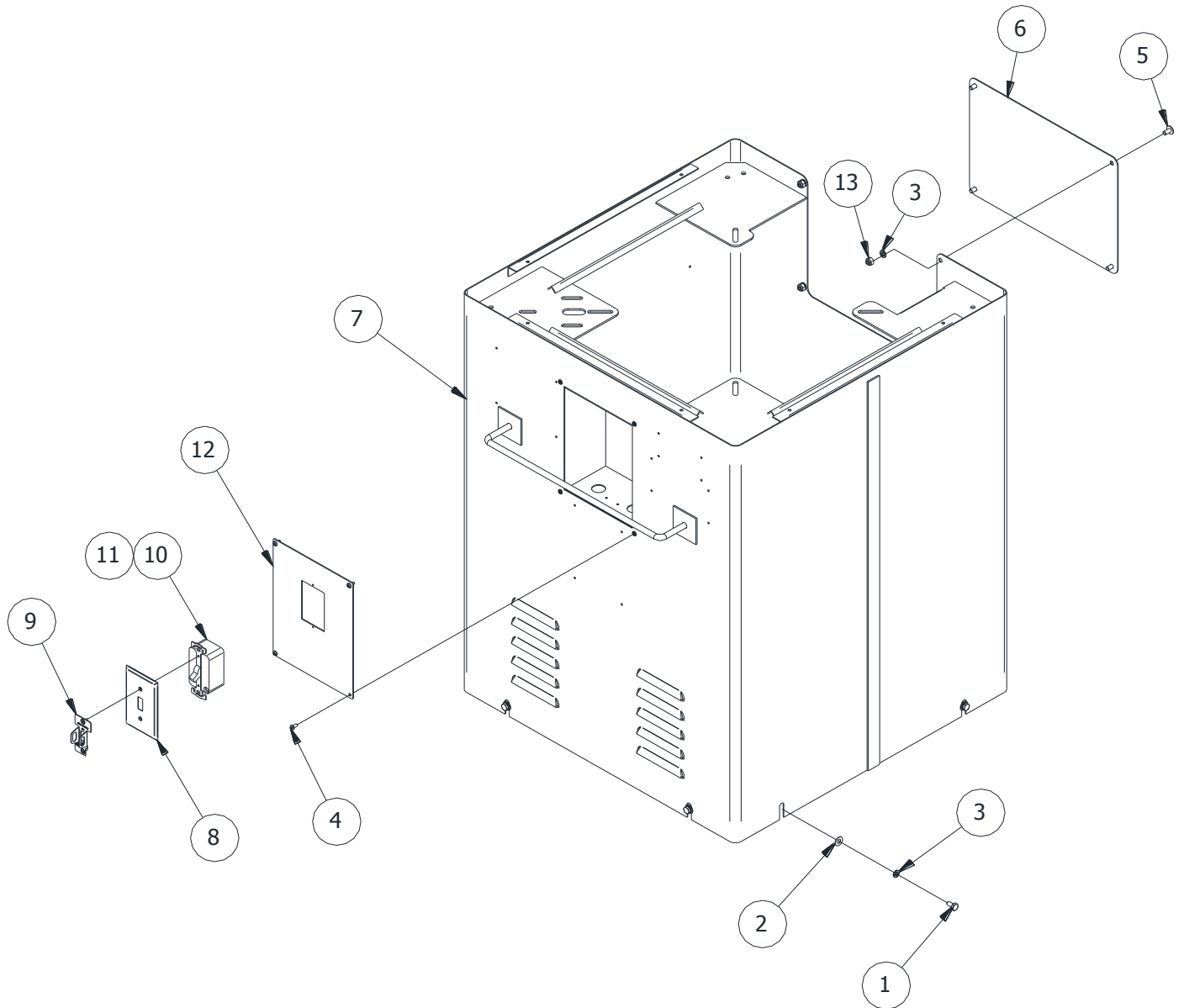

CABINET ASSEMBLY

BILL OF MATERIAL

ITEM	PART NO	DESCRIPTION	QTY
1	F0402HHCS	HEX HEAD CAP SCREW, 1/4-20 X 1/2" L	21
2	F0400FW	FLAT WASHER, 1/4"	25
3	F0400LW	LOCK WASHER, 1/4"	29
4	F9725PHS	PAN HEAD, SLOTTED, 8-32 UNC x 0.375	4
5	F0402BH	BUTTON HEAD 1/4-20 X 1/2" LG.	4
6	R418CA	COVER PLATE	1
7	R416CA	CABINET ASSEMBLY	1
8	SS115	SINGLE SWITCH COVER PLATE, S.S.	1
9	R406CA	LOCKING ATTACHMENT, SWITCH	1
10	SS212	MANUAL MOTOR STARTER SINGLE SWITCH (STANDARD 120/220Vac MACHINE ONLY - SEE ELECTRICAL PORTION OF MANUAL FOR 3PHASE MACHINES)	1
11	SS210	OVERLOAD (USED WITH 110-120Vac MACHINES)	1
	EL-1189	OVERLOAD (USED WITH 208-240Vac MACHINES)	
12	R422CA	SWITCH PLATE (SINGLE PHASE MACHNINE)	1
	17799	SWITCH PLATE (220Vac THREE PHASE MACHINES ONLY)	
13	F0400NLN	NUT, NYLOCK 1/4"	12
14	F0404SH	SCREW, SOCKET HEAD 1/4-20 X 1"LG	4

ROUNDER ASSEMBLY

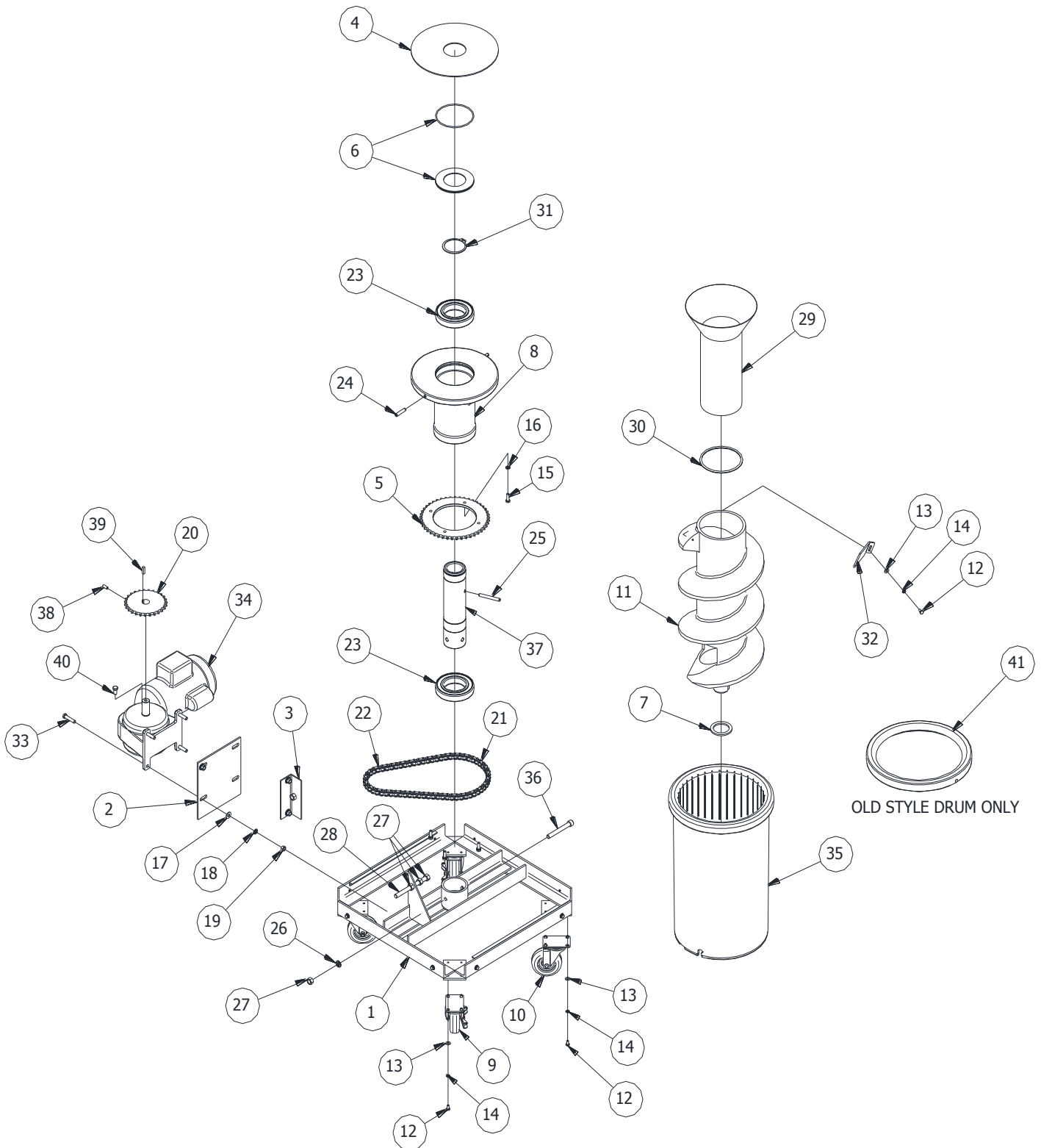

ROUNDER ASSEMBLY

BILL OF MATERIAL

ITEM	PART NO	DESCRIPTION	QTY
1	R130RA2	OUTSIDE FRAME	4
2	N/A	WELDED TO ITEM #1 SHOWN APART FOR CLERTY	1
3	R144RA	MOTOR ADJUSTING BRACKET	1
4	R141RA	PLASTIC SEAL RING	1
5	R109RA	ROUNDER BASE SPROCKET	1
6	R134RA	PLASTIC WASHER w/ O'RING	1
7	R142RA	WASHER	1
8	❖ R108RA-B	ROUNDER BASE (FOR ASSEMBLY, SEE NOTE BELOW)	1
9	621CA1	CASTER, SWIVEL (LOCKING)	2
10	621CA2	CASTER, SWIVEL (NON-LOCKING)	2
11	AR122RA	ROUNDING SCREW (INCLUDES ITEM #'S 7, 12, 13, 14 & 32)	1
12	F0402HHCS	HEX HEAD CAP SCREW, 1/4-20 X 1/2" L	17
13	F0400FW	FLAT WASHER, 1/4"	17
14	F0400LW	LOCK WASHER, 1/4"	17
15	F0504HHCS	HEX HEAD CAP SCREW 5/16-18 X 1" LG.	4
16	F0500LW	LOCK WASHER, 5/16"	4
17	F0600FW	FLAT WASHER 3/8"	4
18	F0600LW	LOCK WASHER 3/8"	4
19	F0600NC	NUT COURSE, 3/8	4
20	R103RA	SPROCKET,(MOTOR) (INCLUDES ITEM #'S 38 & 39)	1
21	R105RA	DRIVE CHAIN - 31 LINKS	1
22	R106RA	MASTER CHAIN LINK	1
23	R135RA	BEARING, (ROUNDER BASE)	2
24	F0607RP	ROLL PIN, 3/8" DIA X 1-3/4" LONG	2
25	F0612RP	ROLL PIN - 3/8" DIA X 3" LONG	1
26	F0800LW	LOCK WASHER 1/2"	1
27	F0800NC	NUT COURSE, 1/2-13 NORMAL	4
28	F0824SD	STUD, 1/2-13 X 6" LG (S.S.)	1
29	R116RA	ROUNDER FUNNEL	1
30	R143RA	"O" RING	1
31	R145RA	SNAP RING	1
32	R121RA	EXIT RAMP (INCLUDES ITEM #'S 12, 13, & 14)	1
33	F0607HHCS	HEX HEAD CAP SCREW 3/8-16 X 1-3/4"	4
34	SS255	GEARMOTOR (3/4 H.P. / 120/230VAC / SINGLE PHASE)	1
	SS256	GEARMOTOR (1H.P. / 230/460VAC / THREE PHASE /60Hz)	
	EL-1448	GEARMOTOR (2H.P. / 230/460VAC / THREE PHASE / 60Hz)	
35	19900	PLASTIC ROUNDER DRUM	1
36	F0816SH	1/2-13 SOCKET HEAD BOLT 4" LONG	1
37	R108RA-S	ROUNDER SPINDLE (INCLUDES ITEM #'S 25 & 31)	1
38	F0503SS	SET SCREW, 5/16-18 X 3/4" LG, S.S.	1
39	F0404KY	1/4" KEY X 1" LONG, S.S.	1
40	R133RA	BREATHER	1
41	R115RA	ROUNDER DRUM RING (OLD STYLE DRUM ONLY)	1

❖ **PART # R108RA ROUNDER BASE ASSEMBLY INCLUDES ITEM #'S 5, 6, 8, 15, 16, 23, 24, 25, 31 & 37.**

TABLE ASSEMBLY

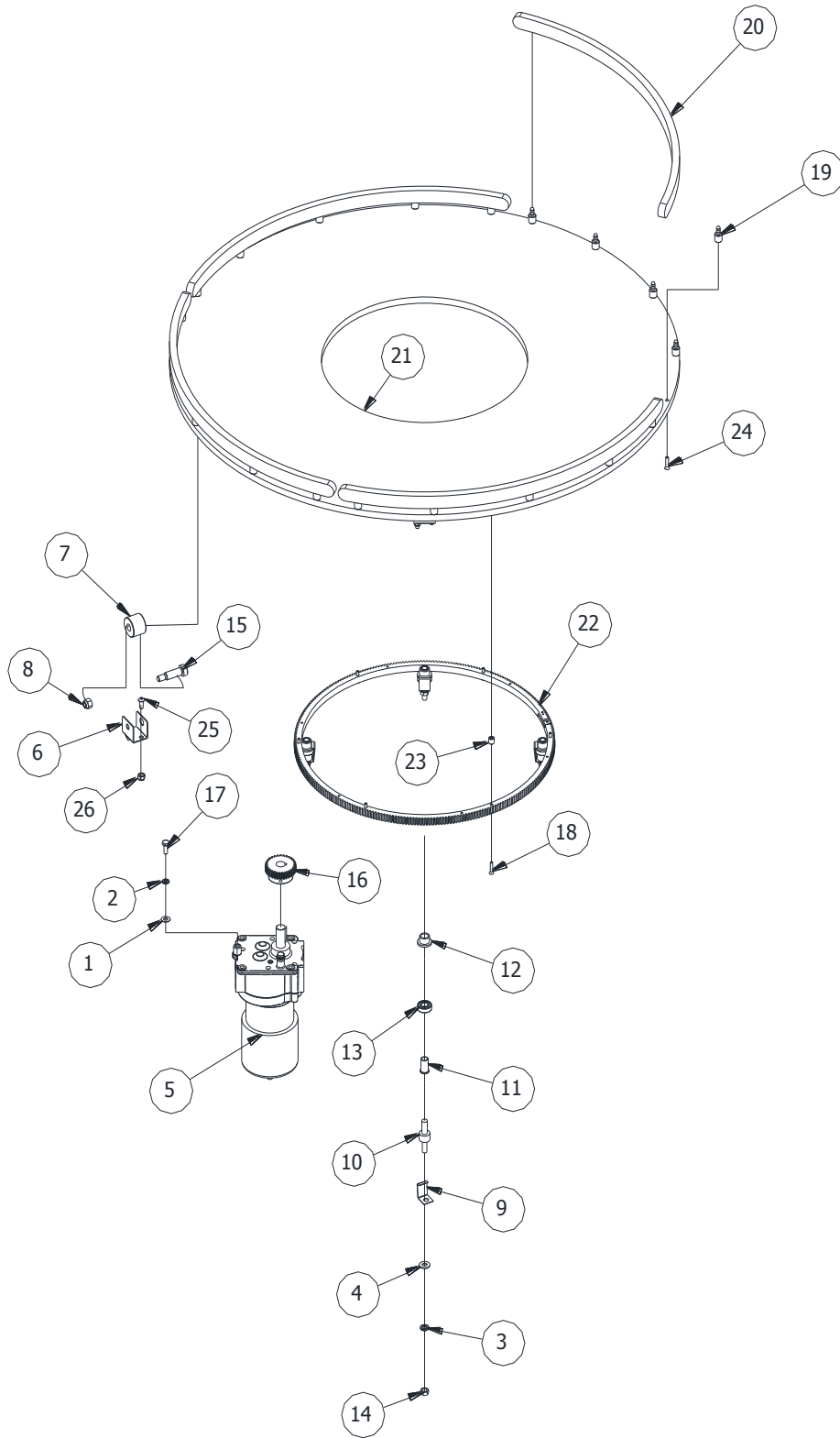

TABLE ASSEMBLY

BILL OF MATERIAL

ITEM	PART NO	DESCRIPTION	QTY
1	F0400FW	FLAT WASHER, 1/4"	25
2	F0400LW	LOCK WASHER, 1/4"	29
3	F0500LW	LOCK WASHER, 5/16"	8
4	F0500FW	FLAT WASHER, 5/16"	8
5	SS252	OUTFEED CONVEYOR MOTOR, 1/15 HP, 115~230V, 70 RPM	1
6	11942	TABLE ROLLER GUIDE BRACKET	4
7	11943	TABLE GUIDE ROLLER	4
8	F0600NLN	NUT-NYLOCK 3/8"	4
9	R218TA	BEARING RETAINER	4
10	R217TA	TABLE SUPPORT BAR	4
11	R216TA	BRONZE BUSHING	4
12	R214TA	PLASTIC BEARING	4
13	R215TA	THRUST BEARING	4
14	F0500NC	NUT COURSE, 5/16-18	4
15	F0805SHSB	SOCKET HEAD SHOULDER BOLT, 1/2"DIA SHOULDER X 1-1/4" LONG, 3/8-16 THREADS	4
16	R206TA	DRIVE GEAR - MODIFIED	1
17	F0403HHCS	HEX HEAD CAP SCREW 1/4-20 X 3/4"	3
18	F9703.5SFH	8-32 x 7/8" LONG SLOTTED FLAT HEAD	6
19	17889	TABLE RING MOUNT STAND-OFF	20
20	17903	TABLE RING	4
21	17934	TABLE TOP	1
22	R213TA	RING GEAR ASSEMBLY	1
23	21442	TABLE THREADED INSERT	6
24	F9903.5SFH	10-32 x 7/8" LONG SLOTTED FLAT HEAD	20
25	F0402.5SB	BUTTON HEAD, SOCKET 1/4-20 X 5/8" LG, S.S.	8
26	F0400NLN	NUT, NYLOCK 1/4"	12
27	AMTAG160SF	ROUNDER SCREW CAUTION STICKER (ENGLISH & CANADIAN FRENCH)	1

ELECTRICAL COMPONENTS

SINGLE PHASE

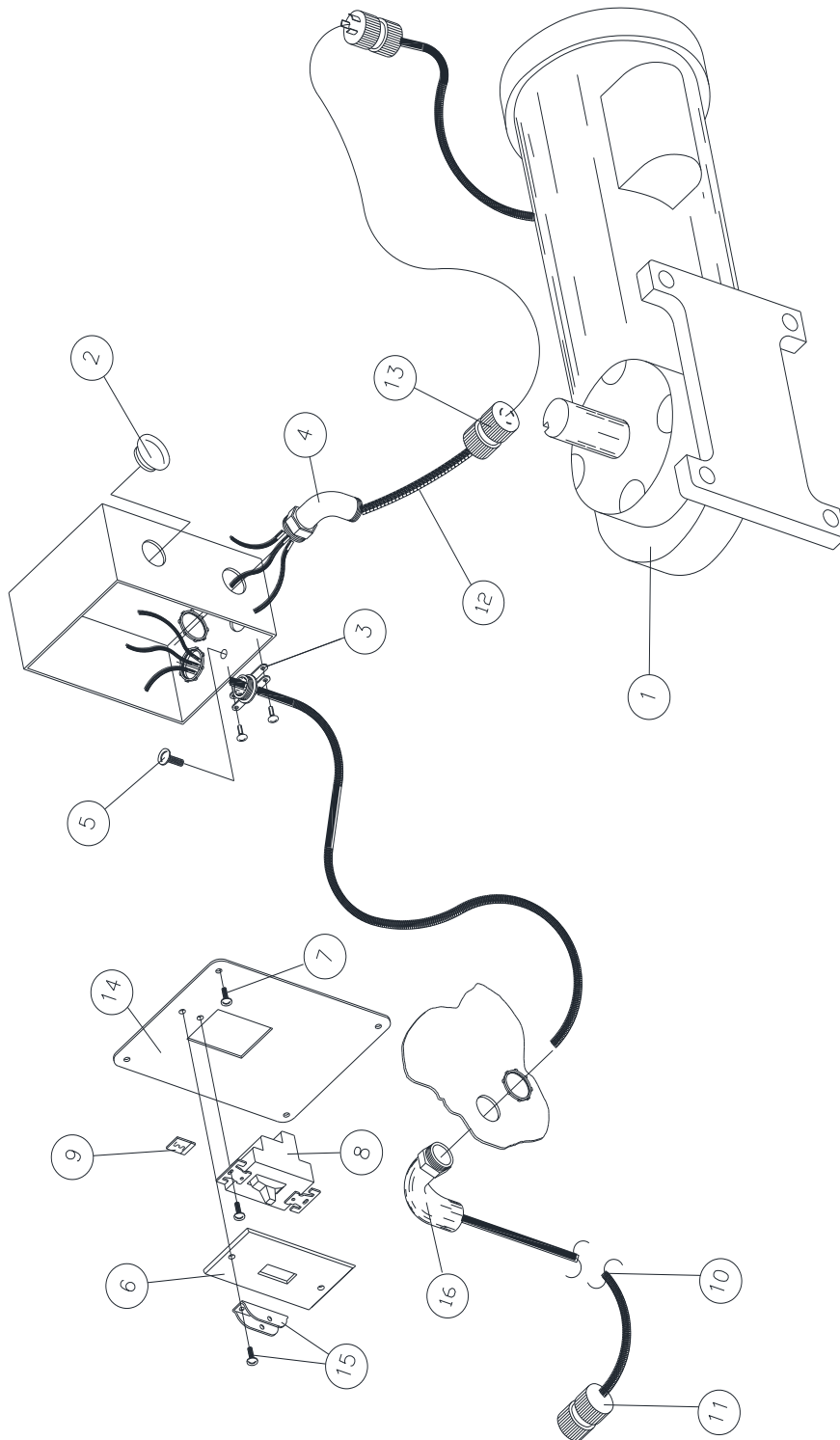

ELECTRICAL COMPONENTS

SINGLE PHASE BOM

ITEM	PART NO	DESCRIPTION	QTY
1	SS255-115	GEAR MOTOR ASSEMBLY (110-120Vac MACHINE)	1
		W/ SS255 - GEAR MOTOR	1
	SS255-115	SS220 - 14/3 CAROLPRENE CORD	18"
		SS100 – CORD CONNECTOR	1
		SS153 - PLUG (110-120Vac)	1
	SS255-220	GEAR MOTOR ASSEMBLY (208-240Vac MACHINE)	1
		W/ SS255 - GEAR MOTOR	1
		SS220 - 14/3 CAROLPRENE CORD	18"
		SS100 – CORD CONNECTOR	1
		SS155 - PLUG (208-240Vac)	1
2	EL-1321	HOLE PLUG (S.S.)	2
3	SS100	CORD CONNECTOR	1
4	SS103	90° ELBOW	1
6	F9702TH	SCREW (8-32 X ½" LONG TRUSS HEAD)	2
6	SS115	SWITCH COVER PLATE	1
7	F9701.5TH	SCREW (8-32 X 3/8" LONG TRUSS HEAD)	4
8	SS212	MANUAL MOTOR STARTER	1
9	SS210	OVERLOAD (USED WITH 110-120Vac MACHINES)	1
	EL-1189	OVERLOAD (USED WITH 208-240Vac MACHINES)	
10	SS220	POWER CORD (14/3)	12'
11	SS148	PLUG (110-120Vac MACHINES)	1
	SS155	PLUG (208-240Vac MACHINES)	
12	SS220	MOTOR DROP CORD(14/3)	16-1/2"
13	SS154	MOTOR CONNECTOR (USED WITH 110-120Vac MACHINES)	1
	SS156	MOTOR CONNECTOR (USED WITH 208-240Vac MACHINES)	
14	R422CA	SWITCH PLATE	1
15	R406CA	LOCKING ATTACHMENT	1
16	EL-1406	90 DEGREE CORD GRIP	1

ELECTRICAL COMPONENTS

THREE PHASE

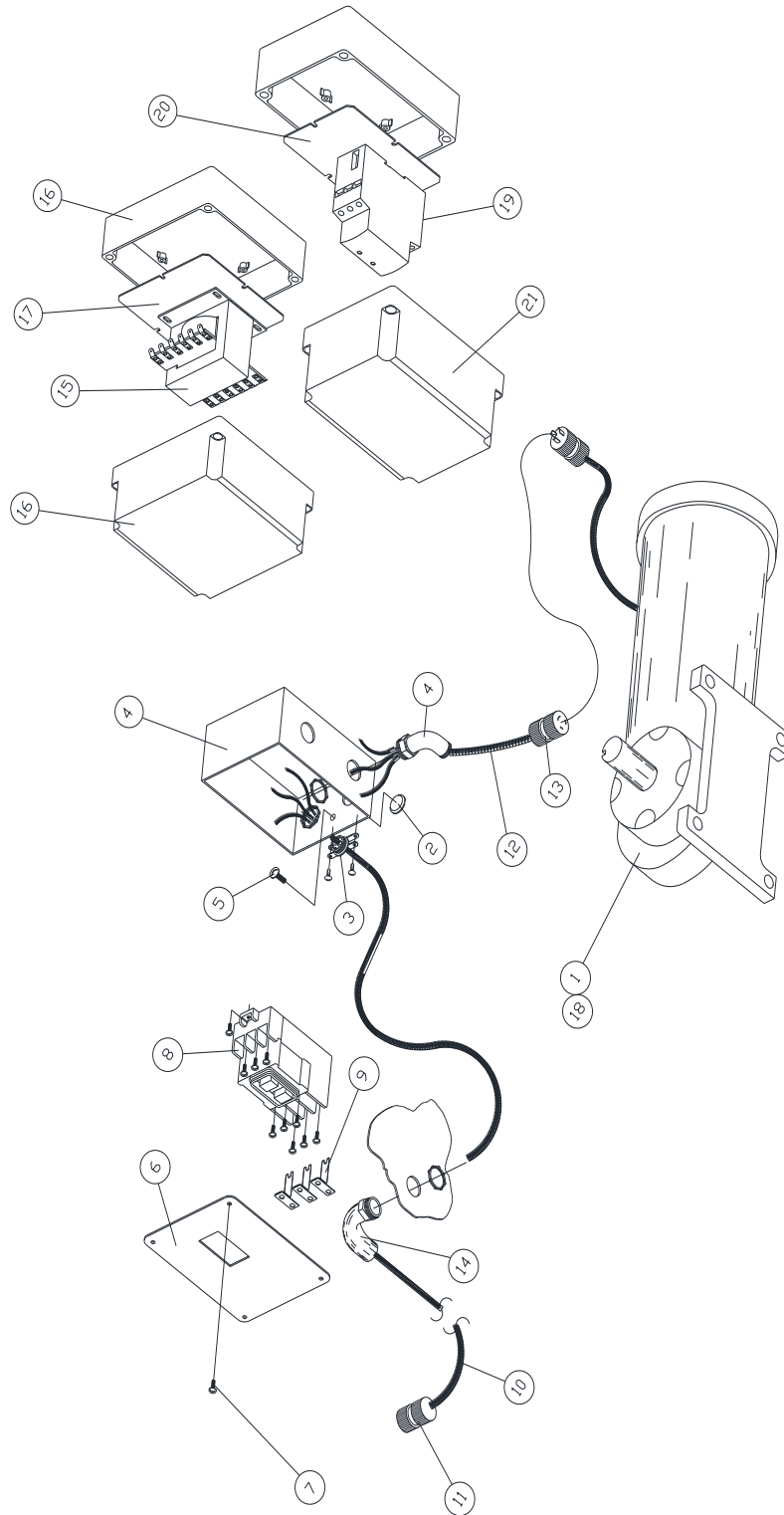

ELECTRICAL COMPONENTS

THREE PHASE BOM

ITEM	PART NO	DESCRIPTION	QTY
1	SS256-220	GEAR MOTOR ASSEMBLY (208-240Vac MACHINE)	1
		W/ SS256 - 1HP GEAR MOTOR	1
		SS225 - 16/4 CAROLPRENE CORD	18"
		SS100 – CORD CONNECTOR	1
		SS159 - PLUG (208-240Vac)	1
	SS256-480	GEAR MOTOR ASSEMBLY (440-480Vac MACHINE)	1
		W/ SS256 - 1HP GEAR MOTOR	1
		SS225 - 16/4 CAROLPRENE CORD	18"
		SS100 – CORD CONNECTOR	1
		SS161 - PLUG (480Vac)	1
2	EL-1321	HOLE PLUG (S.S.)	2
3	SS100	CORD CONNECTOR	1
4	SS103	90° ELBOW	1
5	F9702TH	SCREW (8-32 X ½" LONG TRUSS HEAD)	2
6	17799	SWITCH COVER PLATE	1
7	F9701.5TH	SCREW (8-32 X 3/8" LONG TRUSS HEAD)	4
8	EL-1202	MANUAL MOTOR STARTER	1
9	EL-1416	OVERLOAD (USED WITH 208-240Vac MACHINES w/ 1HP MOTOR)	3
	EL-1580	OVERLOAD (USED WITH 440-480Vac MACHINES w/ 1HP MOTOR)	
	EL-1579	OVERLOAD (USED WITH 208-240Vac MACHINES w/ 2HP MOTOR)	
	EL-1373	OVERLOAD (USED WITH 440-480Vac MACHINES w/ 2HP MOTOR)	
10	SS219	POWER CORD (14/4)	12'
11	SS159	PLUG (208-240Vac MACHINES)	1
	SS161	PLUG (440-480Vac MACHINES)	
12	SS219	MOTOR DROP CORD(14/4)	16-1/2"
13	SS160	MOTOR CONNECTOR (USED WITH 208-240Vac MACHINES)	1
	SS162	MOTOR CONNECTOR (USED WITH 440-480Vac MACHINES)	
14	SS277	90 DEGREE CORD GRIP	1
15	EL-0220	TRANSFORMER (440-480Vac MACHINES)	1
16	SS381	ELECTRICAL ENCLOSURE	1
17	SS380	ELECTRICAL ENCLOSURE PANEL	1
18	EL-1448-220	GEAR MOTOR ASSEMBLY (208-240Vac MACHINE)	1
		W/ EL-1448 - 2HP GEAR MOTOR	1
		SS225 - 16/4 CAROLPRENE CORD	18"
		SS100 – CORD CONNECTOR	1
		SS159 - PLUG (208-240Vac)	1
	EL-1448-480	GEAR MOTOR ASSEMBLY (440-480Vac MACHINE)	1
		W/ EL-1448 - 2HP GEAR MOTOR	1
		SS225 - 16/4 CAROLPRENE CORD	18"
		SS100 – CORD CONNECTOR	1
		SS161 - PLUG (480Vac)	1
19	SS384	SMART MOTOR CONTROLLER	1
20	SS387	ELECTRICAL ENCLOSURE	1
21	SS388	ELECTRICAL ENCLOSURE PANEL	1
22	SS105	LIQUIDTIGHT FITTING (NOT SHOWN)	2

ELECTRICAL SCHEMATIC

SINGLE PHASE

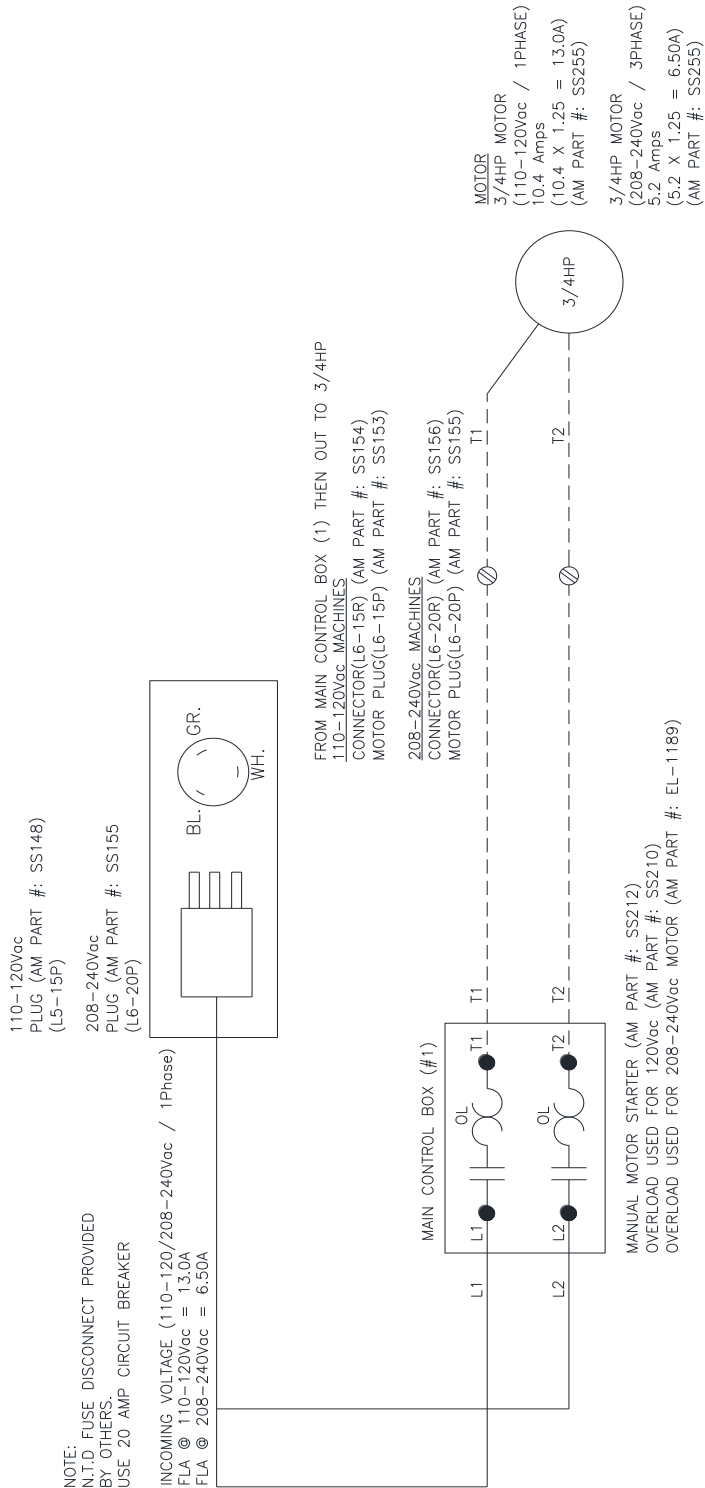

ELECTRICAL SCHEMATIC

208-240Vac - 3 PHASE

NOTE:
 N.T.D FUSE DISCONNECT PROVIDED
 BY OTHERS.
 USE 20 AMP CIRCUIT BREAKER

INCOMING VOLTAGE (208-240Vac / 3Phase)
 FLA(1HP MOTOR) = 4.50A
 FLA(2HP MOTOR) = 7.75A

PLUG (AM PART #: SS159)

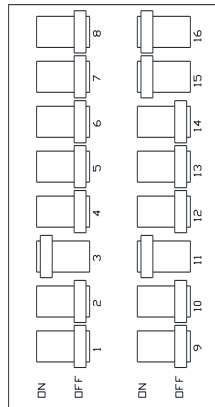
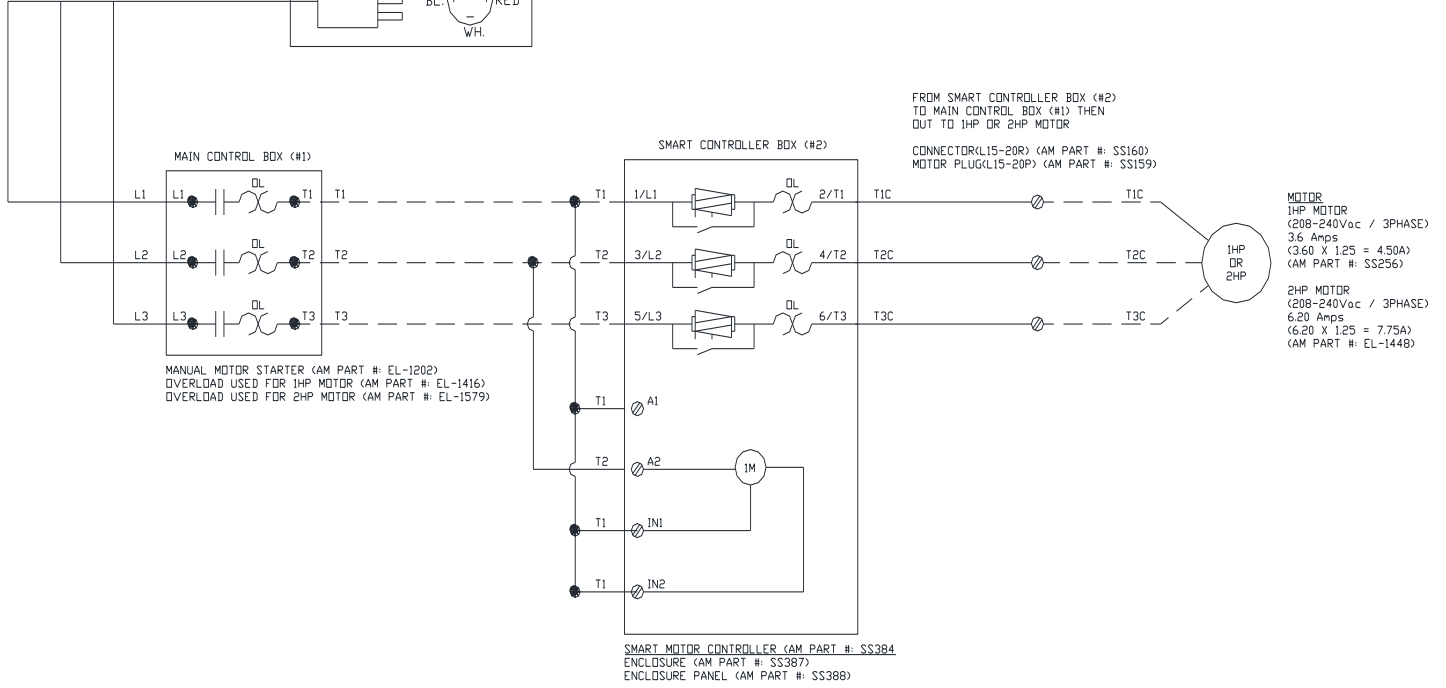
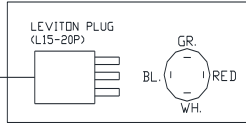

SMART CONTROLLER
 DIP SWITCH SETTINGS

ELECTRICAL SCHEMATIC

460-480Vac - 3 PHASE

NOTE:
 NTD FUSE DISCONNECT PROVIDED
 BY OTHERS.
 USE 20 AMP CIRCUIT BREAKER

INCOMING VOLTAGE (460-480Vac / 3Phase)
 FLA(1HP MOTOR) = 2.59A
 FLA(2HP MOTOR) = 4.22A

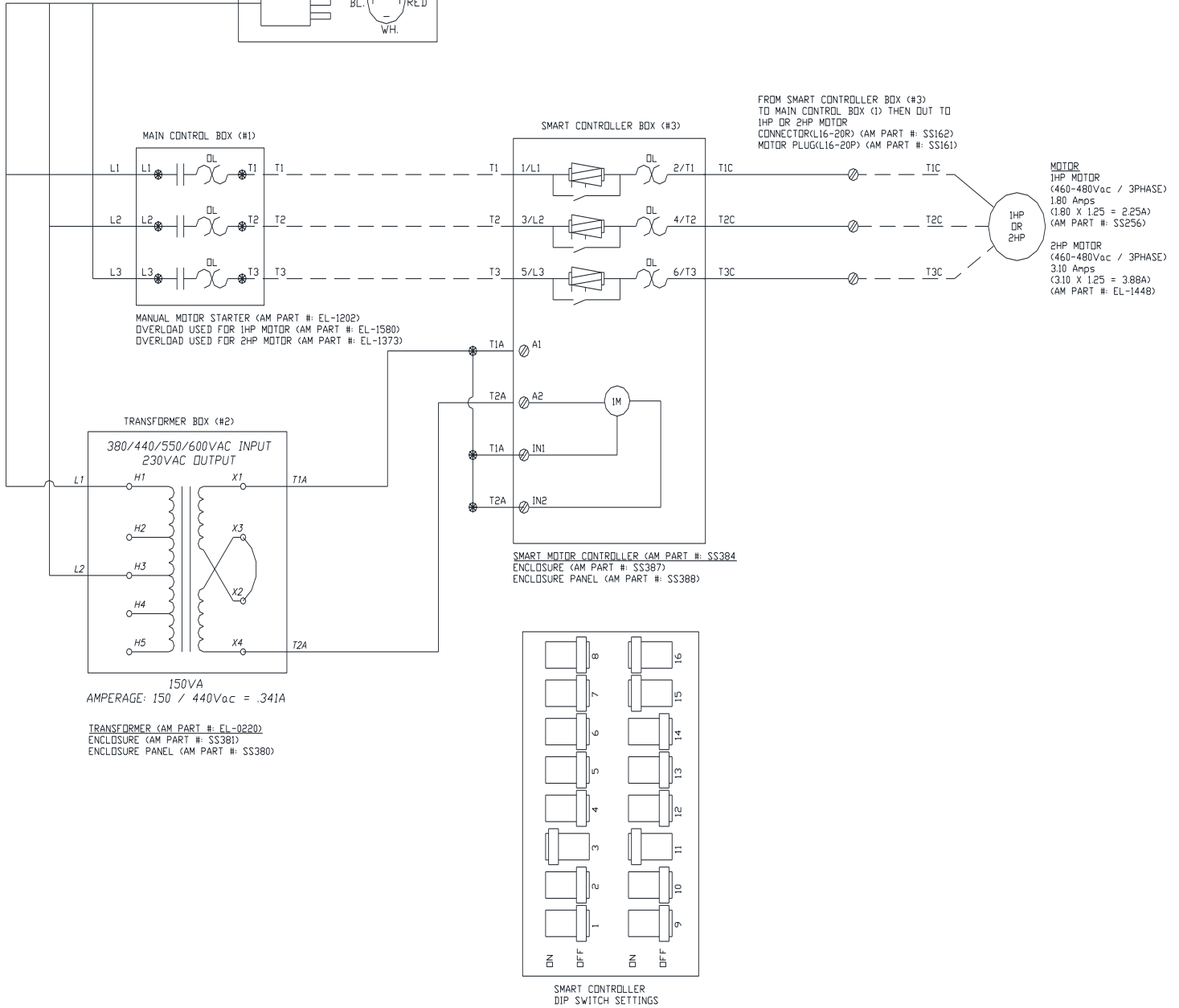
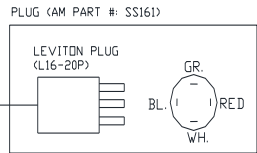

ORDERING REPLACEMENT PARTS

IMPORTANT:

ONLY USE FACTORY SUPPLIED REPLACEMENT PARTS TO MAINTAIN MACHINE SAFETY, PERFORMANCE AND SANITARY CONDITIONS.

USE OF NON-APPROVED PARTS MAY VOID MANUFACTURES WARRANTY.

TO ORDER REPLACEMENT PARTS ALWAYS:

- 1) CHECK THE MACHINE TO IDENTIFY MISSING, DAMAGED OR NON-FUNCTIONAL PARTS INCLUDING GUARDS, WARNING LABELS AND INSTRUCTIONS.
- 2) COMPARE THE LIST WITH THE PARTS DIAGRAMS SUPPLIED.
- 3) RECORD THE COMPLETE MODEL AND SERIAL NUMBER OF THE UNIT.
- 4) CALL AMMANUFACTURING (800) 342-6744 AND PROVIDE ALL INFORMATION NOTED ABOVE TO EXPEDITE ORDER PROCESSING AND HELP REDUCE SHIPPING COST.
- 5) PROVIDE COMPLETE DETAILS FOR (SHIP TO) AND (BILL TO) INFORMATION. TO ASSIST PROMPT DELIVERY, SPECIFY TYPE OF CARRIER PREFERRED IN SHIPMENT.
- 6) MOST MAJOR CREDIT CARDS ACCEPTED.

