

THE ATWOOD
BAGELFORMER

AUTOMATIC BAGEL DIVIDING AND FORMING

MODEL: BF - 110 SERIES II

INCLUDES: RK2200 SERIES MACHINES

OPERATIONS AND SAFETY MANUAL

INCLUDING PARTS CATALOG
AND MAINTENANCE INSTRUCTIONS

MODEL No. _____

SERIAL No. _____



CAUTION:

DO NOT OPERATE, CLEAN OR SERVICE THIS MACHINE BEFORE YOU READ THIS MANUAL, AND ARE FAMILIAR WITH THE SAFETY INSTRUCTIONS IN THIS MANUAL AND THOSE ON THE LABELS ON THE MACHINE. KEEP THIS MANUAL AND OTHER MATERIALS DELIVERED WITH THE MACHINE, ACCESSIBLE TO THE OPERATORS FOR EASY REFERENCE DURING USE.

THE ENTIRE CONTENTS OF THIS PUBLICATION ARE COPYWRITTEN AND ALL RIGHTS ARE RESERVED. REPRODUCTION IN WHOLE OR IN PART IS PROHIBITED WITHOUT WRITTEN PERMISSION OF A.M. MFG. INC.

IF YOU SHOULD HAVE ANY (?) QUESTIONS ABOUT GUARDS OR PLACEMENT CALL (708) 841-0959.

THIS CATALOG BECOMES OBSOLETE ON 12/31/00. UPDATED CATALOGS ARE AVAILABLE DIRECTLY FROM A.M. MFG. INC.



MANUFACTURING COMPANY

DIVISION OF THE ATWOOD CORPORATION
9200 CALUMET AVE. SUITE NW 07 MUNSTER, IN 46321
(219) 474-7272 (800) 342-6744 FAX: (219) 472-7271 www.ammfg.com

OWNERS RESPONSIBILITY

NOTE:

THE PARTS AND EQUIPMENT DESCRIBED IN THIS MANUAL MAY BE COVERED BY ONE OR MORE OF THE FOLLOWING PATENTS:

U.S. PATENT NO. 5,395,229 "BELT SHIELD FOR BAGEL FORMING BELT"

OTHER U.S. AND FOREIGN PATENTS PENDING.



TO MAINTAIN MACHINE AND USER SAFETY, THE RESPONSIBILITY OF THE OWNER IS TO READ AND FOLLOW THESE INSTRUCTIONS AND TO ENSURE THAT ALL OPERATORS UNDERSTAND AND FOLLOW THESE AND OTHER SAFETY INSTRUCTIONS IN THIS MANUAL.

- FOLLOW ALL INSTALLATION INSTRUCTIONS.
- MAKE SURE INSTALLATION CONFORMS TO ALL APPLICABLE LOCAL, STATE, AND FEDERAL CODES, RULES AND REGULATIONS SUCH AS STATE AND FEDERAL OSHA REGULATIONS AND ELECTRICAL CODES.
- CAREFULLY CHECK THE UNIT FOR CORRECT INITIAL FUNCTION.
- READ AND FOLLOW THE SAFETY INSTRUCTIONS. KEEP THEM READILY AVAILABLE FOR MACHINE OPERATORS.
- MAKE CERTAIN ALL OPERATORS ARE PROPERLY TRAINED, KNOW HOW TO SAFELY AND CORRECTLY OPERATE THE UNIT AND ARE PROPERLY SUPERVISED.
- ALLOW UNIT OPERATION ONLY WITH ALL PARTS INCLUDING SAFETY EQUIPMENT, IN PLACE AND OPERATING SAFELY.
- CAREFULLY INSPECT THE UNIT ON A REGULAR BASIS AND PERFORM ALL MAINTENANCE AS REQUIRED.
- SERVICE AND MAINTAIN THE UNIT ONLY WITH AUTHORIZED OR APPROVED REPLACEMENT PARTS.
- KEEP ALL INSTRUCTIONS PERMANENTLY WITH THE UNIT ALONG WITH ALL DECALS AND WARNING LABELS ON THE UNIT CLEAN AND VISIBLE.

TABLE OF CONTENTS

	PAGE
OWNERS RESPONSIBILITIES	INSIDE COVER
INTRODUCTION & SPECIFICATIONS	2
SAFETY SIGNAL WORDS	3
LOCATION OF WARNING LABELS	4
REPRODUCTION OF WARNING LABELS	5
GENERAL SAFETY INFORMATION	6
OPERATING INSTRUCTIONS	7
GUIDE TO CLEANING	8
GUIDE TO MAINTENANCE	9
PARTS CATALOG	
IDLER ROLLER ASSEMBLY	12-13
FORMING ASSEMBLY - MANDREL	14-15
DRIVE ROLLER ASSEMBLY	16-17
ROTARY & STATIONARY TABLE ASSEMBLIES	18
CABINET WELDMENT	19
ELECTRICAL LAYOUT	20
ELECTRICAL DIAGRAM	21
PARTS ORDERING INSTRUCTIONS	22

IMPORTANT:

A.M. MANUFACTURING Co. RESERVES THE RIGHT TO MAKE CHANGES IN DESIGN, SPECIFICATIONS OR MANUFACTURING. TO IMPROVE THEIR PRODUCTS WITHOUT NOTICE AND WITHOUT OBLIGATION TO CHANGE OR IMPROVE PREVIOUSLY BUILT PRODUCTS INCLUDING MANUALS AND CATALOGS.

ONLY USE FACTORY SUPPLIED REPLACEMENT PARTS TO MAINTAIN MACHINE SAFETY, PERFORMANCE AND SANITARY CONDITIONS. USE OF NON-APPROVED PARTS MAY VOID MANUFACTURERS WARRANTY.

KNOW YOUR UNIT. COMPARE DIAGRAMS IN THIS MANUAL WITH THE UNIT BEFORE STARTING SERVICE, TO OBTAIN MAXIMUM SAFETY AND PERFORMANCE.

TO ORDER REPLACEMENT PARTS:
TURN TO PAGE 22 OF THIS MANUAL.



WARNING:

THIS MANUAL CONTAINS CRITICAL SAFETY INSTRUCTIONS. READ AND FOLLOW THEM CAREFULLY. FAILURE TO FOLLOW WARNING AND INSTRUCTIONS MAY LEAD TO SERIOUS PERSONAL INJURY. THE OWNER IS RESPONSIBLE FOR MAINTAINING THE UNIT, ITS INSTRUCTIONS AND DECALS FOR OPERATION REFERENCE. FOR ADDITIONAL COPIES CONTACT A.M. MANUFACTURING: (800)342-6744

OPERATIONS AND SAFETY MANUAL INCLUDING PARTS CATALOG

**READ AND FAMILIARIZE YOURSELF WITH THIS MANUAL BEFORE OPERATING THIS MACHINE
FOLLOW INSTRUCTIONS DURING USE**

INTRODUCTION

THE BF-100 BAGEL FORMER IS DESIGNED TO GIVE YOU OPTIMUM TROUBLE FREE, TIME SAVING SERVICE. IT IS DESIGNED TO FORM THE REQUIRED WEIGHT FOR THE MANDREL USED ON AVERAGE DOUGH. WITH A SPEED RANGE OF UP TO 4800 PIECES PER HOUR, DEPENDING ON SIZE. NEW AND CURRENT EMPLOYEES CAN BE TAUGHT TO OPERATE THIS MACHINE EFFICIENTLY AND SAFELY IN A SHORT PERIOD OF TIME. WE URGE YOU TO STUDY THIS OPERATION AND SAFETY MANUAL FOR FULL BENEFITS.



CAUTION:

ALL OPERATORS MUST BE FULLY TRAINED AND INSTRUCTED IN SAFETY PROCEDURES BEFORE BEGINNING PRODUCTION.

SPECIFICATIONS

SPEED	UP TO 4800 PIECES PER HOUR DEPENDING ON SIZE	FORMER	3 PHASE, 1 H.P. MOTOR
WIDTH OF MACHINE	26"	CONVEYOR BELT	COTTON, STANDARD 180" X 9" WIDE
WORKING HEIGHT OF MACHINE	34" - 42"		ADJUSTABLE TIGHTENER
HEIGHT OF MACHINE	50"	BAGEL MANDRELS	FULLY ADJUSTABLE FOR CENTERING 1 1/2" TO 2" DIAMETER
LENGTH OF MACHINE W/ROTARY TABLE	110"		OTHER SIZES AVAILABLE PER REQUEST
LENGTH OF MACHINE W/OUT ROTARY TABLE	86"	2 WORK TABLES	1 - STATIONARY - 17" X 23" 1 - REVOLVING - 24" DIAMETER
1 MOTOR STARTER - TO OPERATE FORMER			
SHIPPING WEIGHT	450 lbs.		

VOLTAGES: 3 PHASE, 208/220 VOLTS

INSTALLATION INSTRUCTIONS

LOCATION:

SELECT LOCATION CAREFULLY. THE AREA SHOULD PROVIDE THE OPERATOR WITH ENOUGH SPACE TO USE THE EQUIPMENT IN A SAFE MANNER. THE FLOOR AREA SELECTED SHOULD BE EASY TO CLEAN AND SHOULD BE FREE OF OIL, GREASE, ECT. AVOID AREAS WHERE BYSTANDERS AND CUSTOMERS MAY BE PRESENT.



CAUTION

PROPER UNIT INSTALLATION IS NECESSARY FOR SAFE AND EFFICIENT OPERATION. PROPER INSTALLATION ALSO HELPS PROTECT THE UNIT FROM DAMAGE AND MAKES SERVICE EASIER.

SAFETY

THIS MACHINE IS DESIGNED TO PROVIDE FOR SAFE OPERATION IF NORMAL OPERATING PROCEDURES AND SAFETY MESSAGES LOCATED ON THE MACHINE AND IN THIS MANUAL ARE FOLLOWED.



THIS IS A SAFETY ALERT SYMBOL. YOU WILL FIND IT ON VARIOUS SAFETY LABELS ON THE MACHINE AND IT WILL ALSO APPEAR IN THIS MANUAL WHEREVER SAFETY MESSAGES ARE GIVEN.

GET FAMILIAR WITH SIGNAL WORDS:

CAUTION, WARNING & DANGER

CAUTION:

INDICATES A POTENTIALLY HAZARDOUS SITUATION WHICH, IF NOT AVOIDED, MAY RESULT IN MINOR OR MODERATE INJURY. IT MAY ALSO BE USED TO ALERT AGAINST UNSAFE PRACTICES.

WARNING:

INDICATES A POTENTIALLY HAZARDOUS SITUATION WHICH, IF NOT AVOIDED, COULD RESULT IN DEATH OR SERIOUS INJURY.

DANGER:

INDICATES AN IMMINENTLY HAZARDOUS SITUATION WHICH, IF NOT AVOIDED, WILL RESULT IN DEATH OR SERIOUS INJURY. THIS SIGNAL WORD IS TO BE LIMITED TO THE MOST EXTREME SITUATIONS.

NOTE:

A NOTE PROVIDES KEY INFORMATION TO MAKE PROCEDURES EASIER AND CLEARER.

TYPICAL WARNING LABEL LOCATIONS

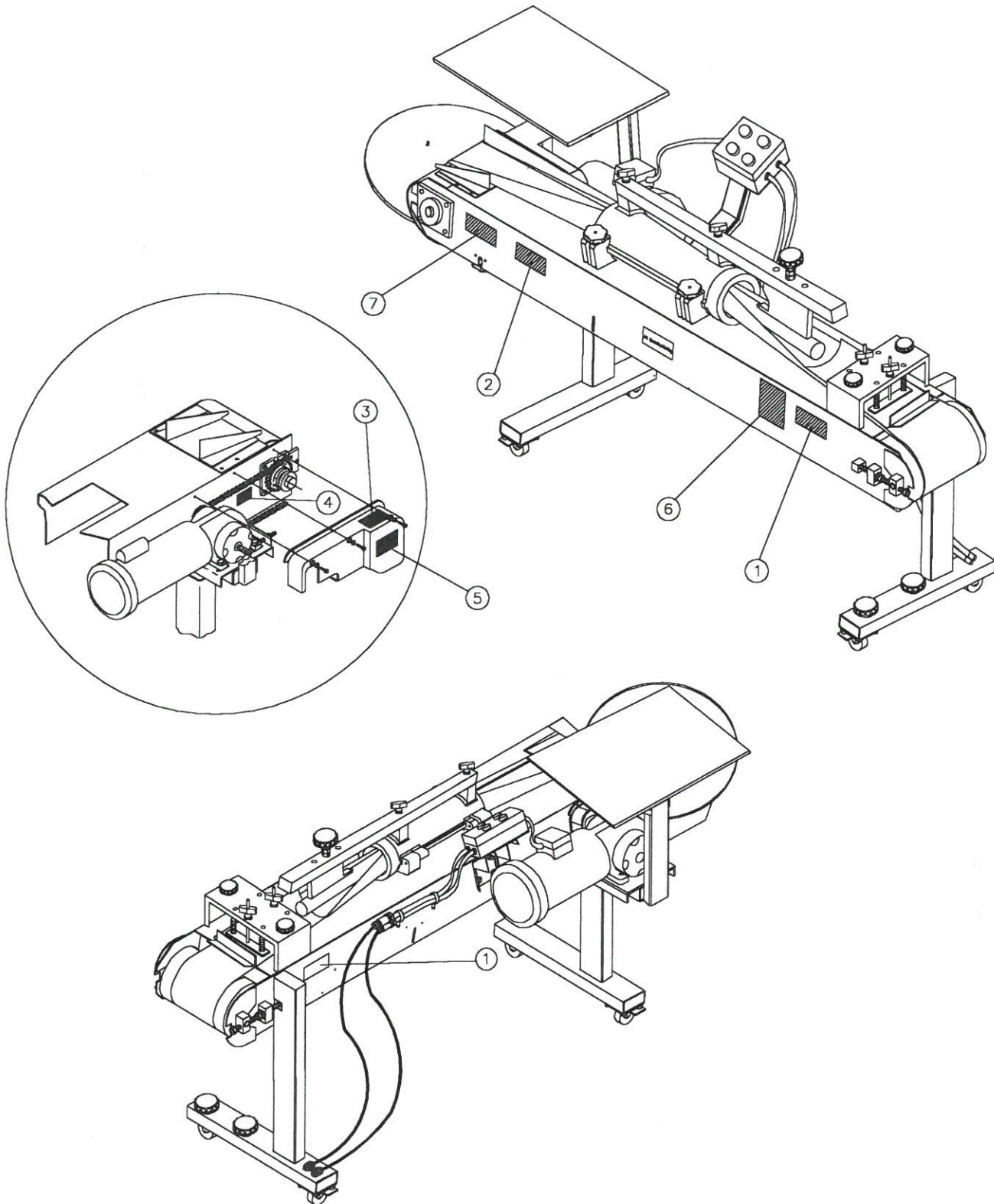

WARNING LABELS TYPICALLY FOUND ON THE BAGEL FORMER 100

PART NO. AM MFG. #14

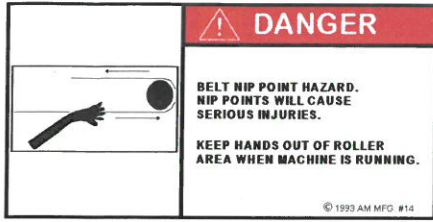

1

RIGHT / LEFT SIDE OF MAIN FRAME AT IDLER PULLEY END

PART NO. AM MFG. #9B



2

RIGHT / LEFT SIDE OF MAIN FRAME AT DRIVE PULLEY END.

*MAY BE REPLACED WITH A.M. MFG. # 24 ON CHAIN GUARD FOR DRIVE PULLEY.

3 PART NO. AM MFG. #11



LOCATED ON TOP OF CHAIN GUARD ON DRIVE PULLEY END.
 LOCATED FRONT AND CENTER OF FORMING TUBE ASSEMBLY

4 PART NO. AM MFG. #24



LOCATED ON SIDE OF MACHINE, UNDER CHAIN GUARD.

5 PART NO. AM MFG. #10
 LOCATED ON SIDE OF CHAIN GUARD ON DRIVE PULLEY END.



7 PART NO. AM MFG. #25

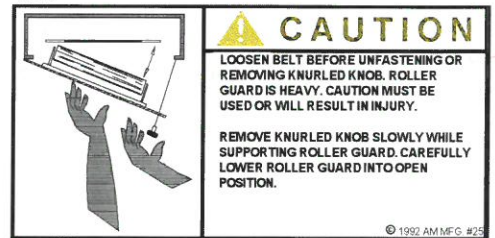

LOCATED OPPOSITE SIDE OF CHAIN GUARD ON DRIVE PULLEY END.

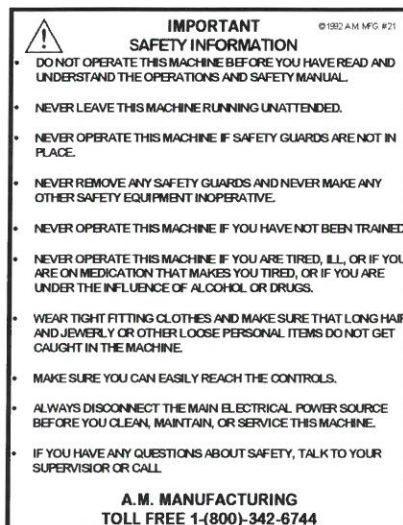

6 PART NO. AM MFG. #21
 LOCATED ON MAIN FRAME TO THE RIGHT OF THE CONTROL PANEL.



CAUTION:

IF ANY SAFETY LABELS ARE MISSING, **THEY MUST BE REPLACED!** CONTACT YOUR DEALER OR A.M. MFG. FOR REPLACEMENT.

MACHINE DESIGN AND SPECIFICATIONS MAY VARY. ACUAL LABEL DESIGN AND PLACEMENT SUBJECT TO CHANGE WITHOUT NOTICE AND MAY VARY FROM THIS ILLUSTRATION.

SAFETY RULES



IMPORTANT:

READ AND FOLLOW THESE SAFETY RULES. THEY ARE FOR YOUR PROTECTION AND THE PROTECTION OF THOSE WORKING WITH YOU.

- DO NOT OPERATE THIS MACHINE BEFORE YOU READ AND UNDERSTAND THE OPERATIONS AND SAFETY MANUAL.
- FOLLOW ALL INSTRUCTIONS DURING USE OF THIS MACHINE.
- LEAVE ALL GUARDS IN PLACE. INSTALL ALL GUARDS IF THEY WERE REMOVED FOR CLEANING, MAINTENANCE, REPAIR OR OTHER REASONS.
- NEVER OPERATE THE MACHINE IF YOU HAVE NOT BEEN TRAINED TO OPERATE THE MACHINE PROPERLY.
- NEVER OPERATE THE MACHINE IF YOU ARE TIRED, ILL, ON MEDICATION, OR UNDER THE INFLUENCE OF ALCOHOL OR DRUGS.
- WEAR TIGHT FITTING CLOTHES. MAKE SURE THAT LONG HAIR, JEWELRY, OR LOOSE PERSONAL ITEMS ARE SECURED SO THEY CANNOT GET CAUGHT IN THE MACHINE. THIS CAN LEAD TO SERIOUS INJURIES.
- MAKE SURE YOU CAN EASILY REACH ALL CONTROLS. IF NOT, A STABLE AND SAFE ELEVATED PLATFORM OR OTHER WORK-AID MUST BE PROVIDED.
- ALWAYS DISCONNECT THE MAIN ELECTRICAL POWER SOURCE BEFORE CLEANING, IF MAINTENANCE OR SERVICE IS PERFORMED, OR IF THE MACHINE IS OUT OF SERVICE.
- NEVER CLEAN BAGEL FORMING BELT ON MACHINE, ALWAYS REMOVE BELT FROM MACHINE TO CLEAN OR SERVICE (WHEN APPLICABLE).
- NEVER LEAVE THIS MACHINE RUNNING UNATTENDED.

IMPORTANT:

IF YOU HAVE ANY QUESTIONS ABOUT THESE SAFETY RULES, SEE YOUR SUPERVISOR OR CALL A.M. MANUFACTURING Co. TOLL FREE: (800)342-6744

OPERATING INSTRUCTIONS

 UNIT MUST BE PROPERLY OPERATED AND MAINTAINED TO PREVENT MACHINE DAMAGE OR PERSONAL INJURY. REVIEW INSTRUCTIONS WITH ALL EMPLOYEES BEFORE USE.

CAUTION:

BEFORE BEGINNING START-UP. READ ALL INSTRUCTIONS AND FAMILIARIZE YOURSELF WITH THE LOCATIONS OF ALL CONTROLS. KNOW HOW TO SHUT DOWN THE UNIT IMMEDIATELY IN CASE OF TROUBLE. MAKE CERTAIN ALL PERSONNEL NOT INVOLVED IN THE START-UP ARE SAFELY AWAY FROM THE MACHINE BEFORE ANY SYSTEMS ARE STARTED.

I. PRELIMINARY START-UP PROCEDURE

- A. PLUG POWER CORD INTO PROPER RECEPTACLE.
- B. PUSH FORMER START BUTTON.
- C. CHECK ROTATION OF DRIVE ROLLERS (100DR) ITEM (1) DRIVE ROLLER ASSEMBLY. IF STANDING IN FRONT OF CONTROL PANEL THE DRIVE ROLLER SHOULD TURN COUNTER CLOCK-WISE (C.C.W.). IF ROTATION IS INCORRECT CONSULT A PROPERLY TRAINED ELECTRICIAN.
- D. IF ROTATION IS CORRECT, YOU ARE READY TO START PRODUCTION.

II. OPERATING THE FORMER

- A. ALL BF-110'S ARE PRE ADJUSTED AND TESTED WITH DOUGH AT THE FACTORY.
- B. IF FURTHER ADJUSTMENTS ARE NEEDED THEY CAN BE MADE AS FOLLOWS:



1.  **STOP MACHINE**
2. IF BAGELS ARE SMALLER ON THE BOTTOM THAN THE TOP, YOU NEED TO RAISE THE MANDREL BAR (BFM2) ITEM (2) FORMING ASSEMBLY (C.W.), OR (C.C.W.). IF THE BAGELS ARE SMALLER ON THE TOP. RESTART THE MACHINE.
3. IF BAGELS ARE SMALLER ON THE RIGHT SIDE, THAN THE LEFT, YOU NEED TO ADJUST THE (BFM2) ITEM (2)
4. REVERSE THE STEP IF BAGELS ARE SMALLER ON THE OPPOSITE SIDE.
5. RESTART THE MACHINE.

II. TENSIONING OF BAGEL BELT

- A. TO LOOSEN & TIGHTEN BAGEL BELT.

1.  **STOP MACHINE**
2. WITH ADJUSTING KNOB, TURN HEX NUTS LOCATED WITH IN NOTCH AREA AT REAR OF IDLER ROLLER GUARDS. IDLER ROLLER GUARDS ARE SHOWN AS ITEM 4 IN IDLER ROLLER ASSEMBLY DRAWING PAGE 12. TURN HEX NUTS CLOCKWISE TO LOOSEN BELT AND COUNTER CLOCKWISE TO TIGHTEN BELT.
3. NEVER ADJUST ONE HEX NUT INDEPENDENTLY OF THE OTHER MORE THAN FIVE ROTATIONS. DURING THE TIGHTENING OR LOOSENING PROCESS, ALTERNATE FROM RIGHT TO LEFT SIDE EQUALLY ADJUSTING EACH.

- A. TO REMOVE THE BAGEL BELT.

1.  **STOP THE MACHINE**
2. REMOVE PRESSURE PLATE ASSEMBLY BY REMOVING BOTH KNOBS (800PHK) ITEM (9) FORMING ASSEMBLY. SLOWLY LIFT AND REMOVE MOUNTING BRIDGE (104IR) ITEM (5) IDLER ROLLER ASSEMBLY WITH PRESSURE PLATE ASSEMBLY STILL INTACT.
3. REMOVE KNURLED KNOB (113DR) ITEM (26) DRIVE ROLLER ASSEMBLY.
4.  **CAUTION:** REMOVE KNOB SLOWLY WHILE SUPPORTING ROLLER GUARD AND ASSEMBLY (115DR-A) ITEMS (25) DRIVE ROLLER ASSEMBLY. CAREFULLY LOWER GUARD INTO OPEN POSITION. BAGEL BELT CAN NOW BE REMOVED.
- 5.

CLEANING PROCEDURES

THESE PROCEDURES ARE VERY IMPORTANT TO MAINTAIN PRODUCT QUALITY AND MACHINE PERFORMANCE AND TO ASSURE SAFETY.

ALL A.M. MANUFACTURING MACHINE ARE TESTED WITH DOUGH DURING THE IN-HOUSE RUN-IN AND QUALITY AUDIT PROCEDURE. ALTHOUGH THE MACHINE HAS BEEN CLEANED, SOME EVIDENCE OF DOUGH ON AND IN THE MACHINE MAY BE DETECTED. THIS IS NORMAL. ALL PARTS IN CONTACT WITH DOUGH SHOULD BE WASHED THOROUGHLY AFTER USE, USING A MILD SOAP AND WATER SOLUTION. DISASSEMBLY OF THIS MACHINE FOR CLEANING IS OUTLINED BELOW AND ILLUSTRATED FOR YOUR CONVENIENCE.

1.  **CAUTION: SHUT OFF ALL ELECTRICAL POWER.**
2. **LOOSEN FORMING BELT.**
3. **REMOVE PRESSURE PLATE ASSEMBLY, CLEAN AND REPLACE.**
4. **REMOVE FORMING TUBES, CLEAN AND REPLACE.**
5. **CAREFULLY LOWER BELT TENSIONING ROLLER, CLEAN AND REPLACE.**
6. **BRUSH EXCESS DOUGH FROM BELT SCRAPER.**
7. **REMOVE BAGEL BELT TO CLEAN & SCRAPE BOTH DRIVE AND IDLER ROLLERS, USING PLASTIC BENCH KNIFE.**

NOTE:

THE BAGEL FORMING BELTS SHOULD REMAIN LOOSE WHEN MACHINE IS NOT IN USE TO AVOID STRETCHING.

 **CAUTION:**

ALWAYS REMOVE BELTS FROM MACHINE FOR CLEANING.

NOTE:

SEE ADJUSTMENT OF BAGEL BELT UNDER OPERATING INSTRUCTIONS ON PAGE (7) OF THIS MANUAL.

 **PRACTICE SAFETY FIRST:**

ALWAYS DISCONNECT ELECTRICAL SERVICE WHEN CLEANING OR MAINTAINING THIS MACHINE, THUS AVOIDING CHANCE OF SERIOUS INJURIES. MACHINES ARE NOT DANGEROUS IF COMMON SENSE IS APPLIED AND THE INSTRUCTIONS ARE CAREFULLY FOLLOWED. THINK AND PRACTICE SAFETY FIRST.

GUIDE TO GENERAL MAINTENANCE

READ AND FOLLOW MAINTENANCE INSTRUCTIONS BELOW TO HELP KEEP THE UNIT IN GOOD OPERATING CONDITION. REFER TO OTHER MATERIALS RECEIVED WITH THE UNIT AND TO SERVICE BULLETINS FROM THE MANUFACTURER FOR ADDITIONAL INSTRUCTIONS FOR PROPER MAINTENANCE AND SERVICE. REGULAR INSPECTIONS AND PROPER MAINTENANCE ARE ESSENTIAL TO HELP PREVENT ACCIDENTS AND INJURIES.



WARNING: BEFORE MAKING ANY INSPECTION, ADJUSTMENT OR REPAIR, BE CERTAIN POWER SOURCE IS DISCONNECTED AND ALL MOVING PARTS ARE BLOCKED OUT TO PREVENT INJURY. WEAR PROTECTIVE CLOTHING.

1. MAKE CERTAIN ALL GUARDS AND COVERS ARE IN PLACE.
2. CHECK FOR WORN, DAMAGED OR MISSING PARTS INCLUDING: BELTS, SAFETY GUARDS AND PROTECTIVE COVERS.
3. MAKE SURE THAT ALL FASTENERS ARE TIGHTENED SECURELY.
4. THE TABLE TOP AND OTHER WORKING SURFACES SHOULD BE CLEANED REGULARLY.
5. ON A DAILY BASIS INSPECT THE UNIT AND CHECK TO BE CERTAIN THAT ALL SYSTEMS ARE OPERATING NORMALLY. DETAILED INSPECTION AND TESTING PROCEDURES ARE SPECIFIED FOR VARIOUS COMPONENTS AT REGULAR INTERVALS. SET UP A CHART AND ASSIGN RESPONSIBILITY FOR THESE ITEMS.



DANGER: ALWAYS DISCONNECT ELECTRICAL SERVICE WHEN CLEANING, MAINTAINING OR REPAIRING THIS MACHINE.



CAUTION: REPLACE ANY DAMAGED OR MISSING SAFETY LABELS. THEY ARE AVAILABLE FROM THE MANUFACTURER.

MAINTENANCE FOR THE BF110 BAGEL FORMER ALWAYS BEGINS WITH KEEPING THE MACHINE CLEAN. PROPER CLEANING PROCEDURES CAN BE FOUND ON PAGE (8) OF THIS MANUAL. STANDARD LONG-TERM MAINTENANCE CONSISTS OF LUBRICATING MAIN WEAR POINTS OF THE MACHINE WITH AN ALL-PURPOSE LITHIUM BASE GREASE. A GREASE GUN WITH A FLEXIBLE HOSE IS NEEDED.

ALL RECOMMENDATIONS FOR MAINTENANCE, BASED ON A 7 DAY, 8 HR. PER DAY WORK SCHEDULE.

THE FIRST STEP OF NORMAL MAINTENANCE IS TO LOCATE THE GREASE FITTING ON THE FIRST OUTER FLANGE BEARING (PART #BDP10), (FIG. 1). WITH A GREASE GUN APPLY A SMALL AMOUNT OF GREASE TO THIS FITTING. THE SECOND BEARING IS SHROUDED BY THE CHAIN GUARD (PART #BFM148-002). THESE PARTS SHOULD BE GREASED ONCE A WEEK.

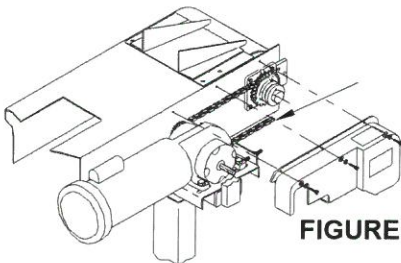

FIGURE 2

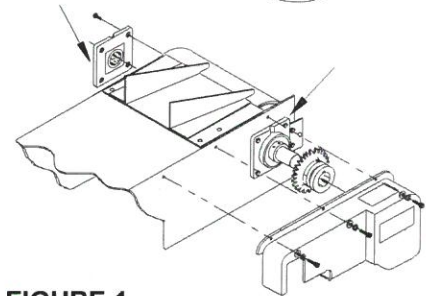
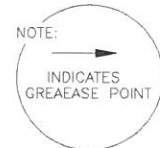

FIGURE 1

THE BF-110 BAGEL FORMER HAS A SINGLE DRIVE CHAIN (PART # 107DR). THIS PART MUST BE OILED REGULARLY WITH A LIGHT- WEIGHT MACHINE OIL TO PROLONG LIFE OF THE SPROCKETS (PART #'S BDP12 / 106DR) AS WELL AS THE CHAIN. LOCATE THE OIL HOLE AT THE TOP OF THE CHAIN GUARD (PART #BFM148-002). THOROUGHLY LUBRICATE THE CHAIN AT THIS POINT. NORMAL OPERATION OF THE FORMER AFTER THIS PROCEDURE, WILL DISTRIBUTE THE OIL OVER THE ENTIRE CHAIN AND SPROCKETS. THIS PROCEDURE MUST BE REPEATED ONCE A WEEK. NOTE: CHAIN CONDITION AND TENSION SHOULD BE CHECKED EVERY 60 DAYS. REMOVE CHAIN GUARD. INSPECT CHAIN AND MAKE NECESSARY ADJUSTMENTS. REPLACE CHAIN GUARD.

FOLLOW NORMAL CLEANING AND MAINTENANCE PROCEDURES OUTLINED IN THIS MANUAL. FOR ANY FURTHER ASSISTANCE CONTACT THE A.M. MFG. SERVICE DEPARTMENT @ (800) 342-6744. THESE INSTRUCTIONS WILL HELP YOU SERVICE THE UNIT. INSTRUCTIONS ARE FOR A PERSON WITH SOME MECHANICAL ABILITY AND TRAINING. NO ATTEMPT HAS BEEN MADE TO DESCRIBE ALL BASIC STEPS. FOR EXAMPLE, HOW TO LOOSEN OR TIGHTEN FASTENERS. ALSO, BASIC PROCEDURES LIKE HOW TO CYCLE SYSTEMS AND CHECK OPERATION OF EQUIPMENT ARE NOT DESCRIBED SINCE THEY ARE EXPECTED TO BE KNOWN TO ANYONE WHO PERFORMS MECHANICAL AND SERVICE WORK. DO NOT ATTEMPT TO PERFORM WORK BEYOND YOUR ABILITY OR AT WHICH YOU HAVE NO EXPERIENCE. IF YOU NEED ASSISTANCE CALL AN AUTHORIZED SERVICE CENTER OR CONTACT A.M. MANUFACTURING SERVICE DEPARTMENT @ (800) 342-6744

ASSEMBLY INSTRUCTIONS

THE BF-110 BAGELFORMER REQUIRES SOME ASSEMBLY BEFORE OPERATING. THE LEGS AND TABLES HAVE BEEN REMOVED FOR SHIPPING PURPOSES.

FAILURE TO ASSEMBLE PROPERLY COULD CAUSE PERSONAL INJURY OR PROPERTY DAMAGE.

CAUTION: FOR SAFE ASSEMBLY, AT LEAST TWO PEOPLE ARE REQUIRED. SOME PARTS ARE HEAVY AND MAY CAUSE STRAIN AND INJURY IF ASSEMBLY IS ATTEMPTED BY JUST ONE PERSON.

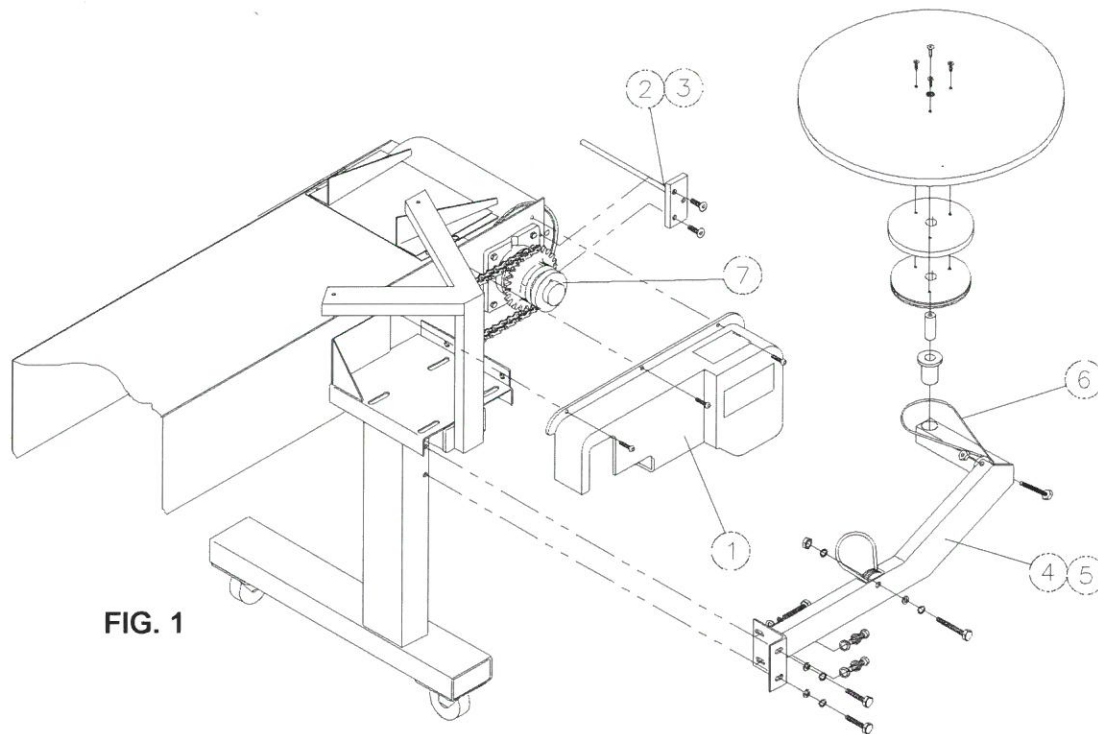

FIG. 1

INSTRUCTIONS FOR TABLE ASSEMBLIES:

1. REMOVE CHAIN GUARD (ITEM 1) AND TRIP BAR ASSEMBLY (ITEM 2 & 3).
2. LOCATE TABLE ARM AND HARDWARE (ITEMS 4 & 5).
 - HARDWARE KIT INCLUDES (4 ea.) F0604HH 5/16-18 x 1" Lg. HEX HEAD BOLTS, F0400FW 5/16" FLAT WASHERS, F0600LW 5/16" LOCK WASHERS.
3. ENSURE ORANGE DRIVE BELT (ITEM 6) IS PROPERLY INSTALLED THROUGH TABLEARM. (ITEM 4) AS SHOWN IN (FIG. 1).
4. PLACE ORANGE DRIVE BELT (ITEM 6) AROUND "V" GROOVE IN THE DRIVE SPROCKET (ITEM 7).
5. LOCATE THE PLASTIC BUSHING ON THE ROTARY TABLE ARM (ITEM 4) AND INSERT THE SHAFT OF THE ROTARY TABLE ASSEMBLY THROUGH THE BUSHING, MAKING SURE THAT THE ORANGE DRIVE BELT (ITEM 6) IS LOOPED AROUND THE TABLE ASSEMBLY (AS SHOWN).
6. TAKE THE ORANGE DRIVE BELT (ITEM 6) AND PLACE IT INTO THE GROOVE ON THE ROTARY TABLE ASSEMBLY.
7. CHECK THE ORANGE BELT (ITEM 6) FOR TENSION AND TO MAKE SURE IT IS NOT RUBBING ON ANY SURFACE AND IS WRAPPED PROPERLY AROUND ALL PULLEYS (AS SHOWN) IN (FIG. 1).
8. REINSTALL CHAIN GUARD (ITEM 1) AND TRIP BAR ASSEMBLY (ITEMS 2 & 3).

NOTE: IF TABLE DOES NOT ROTATE CHECK TO MAKE SURE BELT IS STRAIGHT. SEE ROTARY & STATIONARY TABLE ASSEMBLY FOR DETAILS AND PART NUMBERS.

FORMING BELT TIGHTENING PROCEDURES

WARNING: BEFORE TIGHTENING BELT, BE CERTAIN THAT THE POWER SOURCE IS DISCONNECTED.

FOLLOW STEPS IN ORDER FOR PROPER BELT TENSION.

STEP 1: WITH ADJUSTING KNOB PART NO. 200000, TIGHTEN OR LOOSEN HEX NUT SHOWN AS FIGURE 1, PART NO. 103IR-2. TURN KNOB COUNTER CLOCKWISE NO MORE THAN FIVE ROTATIONS BEFORE MAKING SAME ADJUSTMENT TO OPPOSITE SIDE. (MAKE SURE SWING PLATE IS INSTALLED PRIOR TO USING THIS ALTERNATING PATTERN TO LOOSEN BELT.)

STEP 2: RECONNECT POWER SOURCE AND START THE MACHINE. NOTE HOW THE BELT TRACKS. IF THE BELT TRACKS ON THE CENTER OF THE ROLLER, YOU ARE READY TO START PRODUCTION. IF NOT, DISCONNECT FROM POWER SOURCE AND REPEAT STEP 1, INSURING EQUAL ADJUSTMENT TO EACH SIDE.

STEP 3: TURN ON POWER TO BAGEL FORMER. CHECK TO SEE IF FORMING BELT IS TRACKING IN CENTER OF ROLLER.

STEP 4: IF BELT DRIFTS TO THE RIGHT OR LEFT SHUT OFF POWER AND UNPLUG MACHINE. REPEAT STEP 2, TIGHTENING THE SIDE THAT THE BELT IS TRACKING TO.

STEP 5: REPEAT STEPS 2-4 UNTIL BELT TRACKS IN CENTER OF THE IDLER ROLLER.

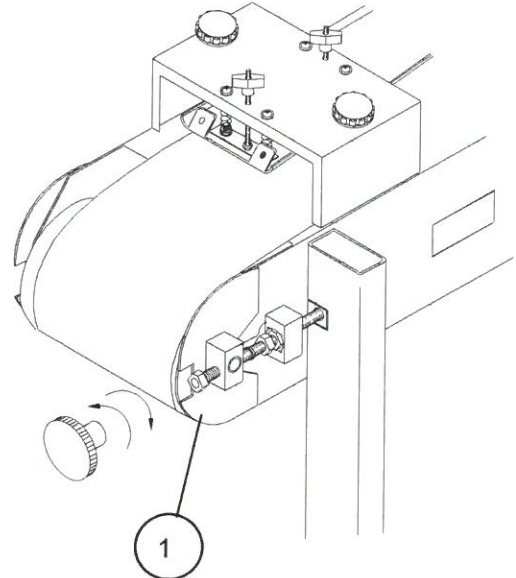

FIGURE 1



IF YOU HAVE ANY (?) QUESTIONS ABOUT GUARDS OR GUARD REPLACEMENT CALL 1- 800-342-6744..

IDLER ROLLER ASSEMBLY



IMPORTANT

KNOW YOUR UNIT. COMPARE DIAGRAMS IN THIS MANUAL WITH THE UNIT BEFORE STARTING SERVICE TO OBTAIN MAXIMUM SAFETY AND PERFORMANCE.

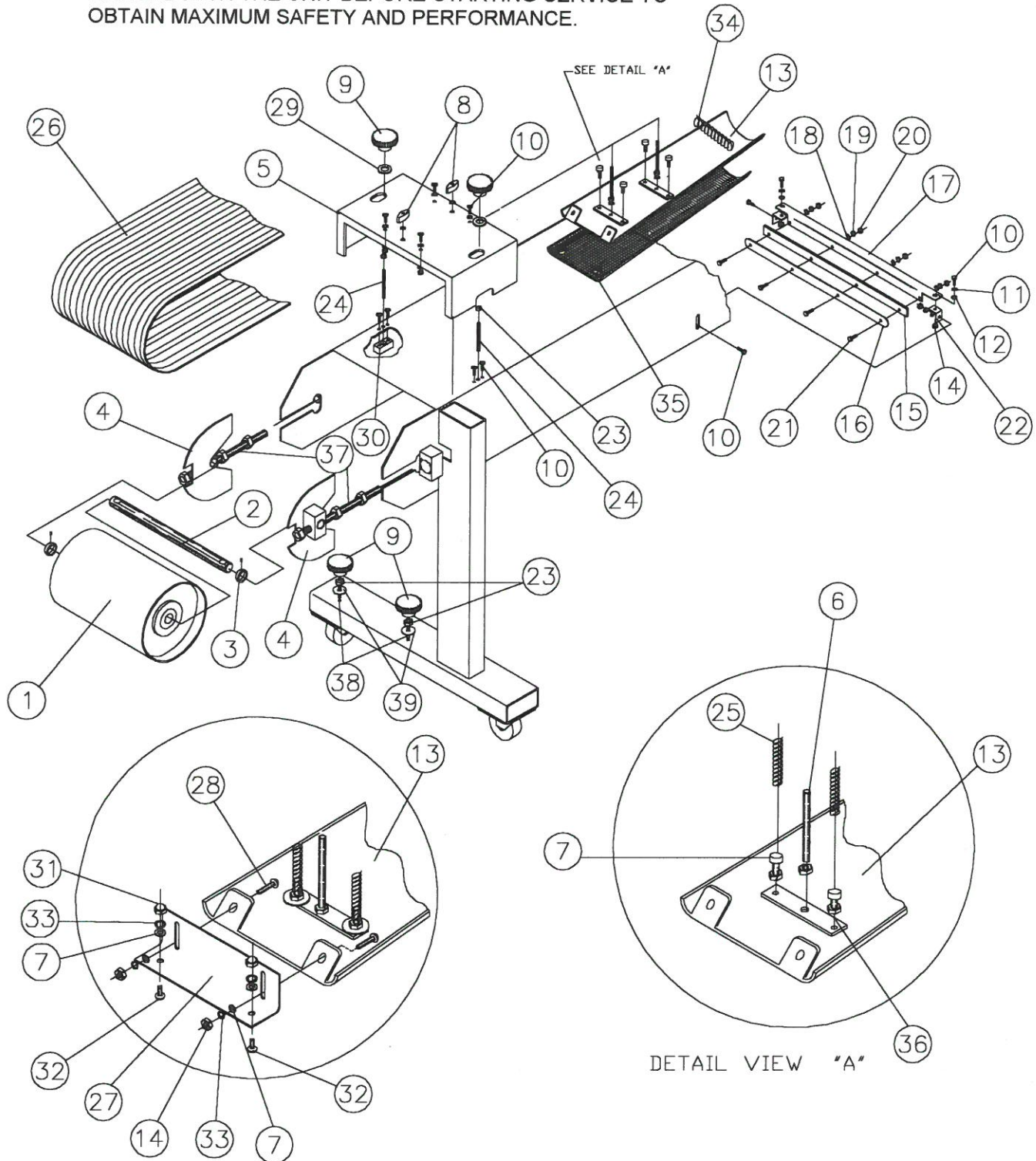

FORMING ASSEMBLY - MANDREL

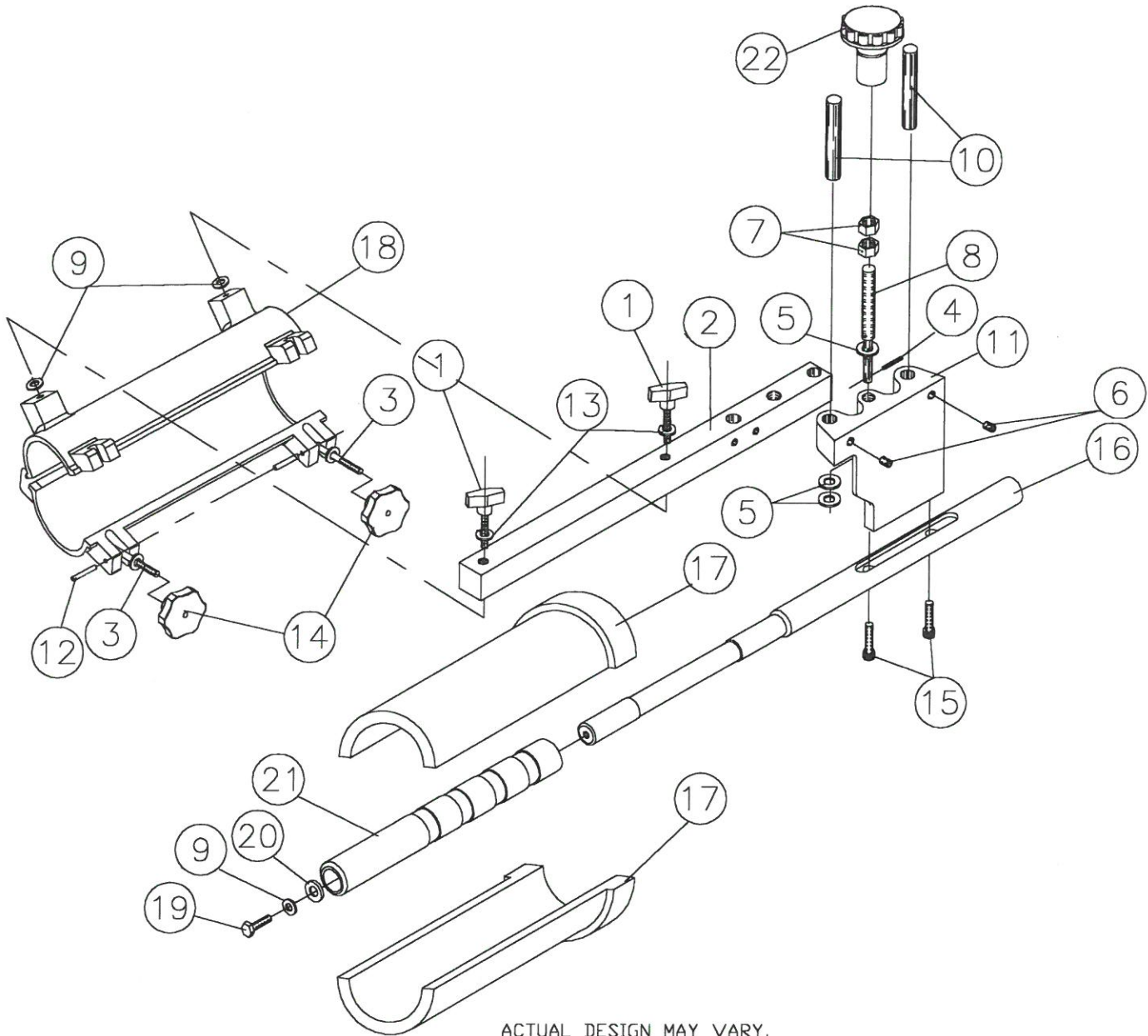

ACTUAL DESIGN MAY VARY,
FROM THIS PICTURE

IDLER ROLLER ASSEMBLY

ITEM	PART NO.	DESCRIPTION	NO. REQ'D
1	100IR	IDLER ROLLER	1
2	101IR-A	IDLER SHAFT	1
3	102IR	SHAFT COLLAR W/ SET SCREW	2
4	103IR-A	ROLLER GUARD L/R	2
5	104IRA	MOUNTING BRIDGE	1
6	F0416SD	1/4-20 THREADED ROD	2
7	F0403SH	SOCKET HEAD	4
8	F000PWNO	1/4-20 LG. THREADED HANDLE	2
9	800PHK	KNOB	4
10	F0404HH	1/4-20 HEX HEAD	12
11	F0400FW	FLAT WASHER	10
12	F0400LW	LOCK WASHER	10
13	SFPP13	PRESSURE PLATE (TOP)	1
14	F0400NC	1/4-20 NUT	12
15	152 RC	PLASTIC STRIP	1
16	132RC	BLADE	1
17	133RC	SUPPORT BRACKET	1
18	F9700LW	LOCK WASHER	4
19	F9700FW	FLAT WASHER	4
20	F9700NC	#8 HEX NUT	4
21	F9703PH	#8 PAN HEAD	4
22	106IR	ANGLE SUPPORT BRACKET	2
23	F0800NC	HEX NUT	2
24	107IR	1/2-13 THREADED ROD	4
25	SFPP19	SPRING	4
26	BDP21	STD. BAGELFORMER 100 BELT	1
27	SFPP18	90° DOUGH GUIDE	1
28	F0404TH	TRUSS HEAD BOLT	6
29	F1400NW	NYLON WASHER	2
30	655CA-14	ADJUSTING BLOCK	2
31	F0400AN	ACORN NUT	2
32	F040RRH	1/4-20 PAN HEAD	2
33	F0400LW	LOCK WASHER	2
34	SFPP12-1A	PRESSURE PLATE FACING SPRING	1
35	SFPP12-1	PRESSURE PLATE FACING	1
36	F0400NC	HEX NUT	6
37	103IR-A2	THREADED ADJUSTING ROD	2
38	F0810SD	1/2-13 THREADED ROD	2
39	F0800FW	FLAT WASHER	2

FORMING ASSEMBLY - MANDREL

ITEM	PART NO.	DESCRIPTION	NO. REQ'D
1	BFM148022	MANDREL BAR ASSEMBLY MOUNT SCREW & KNOB	2
2	BFM2	MANDREL MOUNT BAR	1
3	BFM148018	STUD-LOCKING HINGE	2
4	F0304RP	ROLL PIN	1
5	F0600FW	WASHER	3
6	F0602SS	SET SCREW	2
7	F1000NC	NUT	1
8	BFM12	VERTICAL ADJUSTING SCREW W/2-BFM13 HEXNUT	1
9	F0400LW	LOCK WASHER	3
10	BFM14	VERTICAL SLIDE PIN	2
11	BFM15	MANDREL SUPPORT	1
12	BFM25	ROLL PIN	2
13	F0500FW	WASHER	2
14	BFM19	HANDLE	2
15	BFM20	S.H. SCREW	2
16	BFM23	MANDREL-ADAPTER SUPPORT (STANDARD)	1
17	BFM21	9.0" FORMING TUBE, SET (STANDARD)	1
18	BFM99	FORMING TUBE HOLDER	1
19	F0606HH	BOLT	1
20	BFM33	WASHER 1-3/8 OD X 3/8 ID X 1/8	1
21	BFM35	1-7/8" DIA. MANDREL SLEEVE (STANDARD)	1
22	103IR-A4	BELT ADJUSTING KNOB	1

BFM1AS STANDARD COMPLETE BFM ASSEMBLY FROM MINI TO STANDARD SET-UP INCLUDES:

1-BFM MANDREL MOUNT BAR	1-BFM55 MANDREL ADAPTER SUPPORT
2-BFM14 VERTICAL SLIDE PIN	1-BFM12 VERTICAL ADJUSTING SCREW
1-BFM15 MANDREL SUPPORT	1-BFM21 FORM TUBE RIGHT- OUTER
ADJUSTING ASS. W/ 1-BFM16 VERTICAL PLATE	1-BFM24 FORM TUBE LEFT-INNER
2-BFM7 ROLL PIN	1-BDP21 STANDARD BAGEL CONV. W/BDP21 BELT 9" WIDE
2-BFM8 WASHER	1-BFM39 MANDREL BRIDGE
1-BFM35 MANDREL SLEEVE 1-7/8"	1-BFM11 HEX NUT
1-BFM32 BOLT	1-F0402HH BOLT
1-BFM33 WASHER	1-BFM52L DOUGH SHIELD
2-BFM20 SOCKET HEAD SCREW	2-F0402HH BOLT
1-BFM13 HEX NUT	2-F0400FW FLAT WASHER
1-F0204RP ROLL PIN	2-F0400LW LOCK WASHER
2-F0606SH BOLT	
1-F0602SS SET SCREW	

BFM4A BULL SET-UP ASSEMBLY INCLUDES:

BFM41 FORMING TUBES	BFM37 MANDREL SLEEVE 2" DIA.
BDP22 BULL BAGEL CONV. BELT 10" WIDE	

BFM2A STANDARD COMPLETE BFM ASSEMBLY FROM BULL TO STANDARD SET-UP INCLUDES:

1-BFM35 MANDREL SLEEVE 1-7/8"
 1-BDP21 STANDARD BAGEL CONV. W/ 9" BELT

BFM3A MINI SET-UP FROM STANDARD TO MINI SET-UP & FROM BULL TO MINI SET-UP INCLUDES:

1-BDP23 MINI BAGEL W/6" WIDE CON. BELT	1-BFM2 BAR MANDREL MOUNT
1-BFM40 MINI FORMING TUBE	1-BFM11 HEX NUT
1-BFM42 MANDREL & SUPPORT BAR 1-1/8"	1-BFM12 VERT. ADJUSTING SCREW W/BFM13 HEX NUT
1-BFM15 VERT. PLATE MANDREL SUPPORT ADJUSTING ASSEMBLY	2-BFM14 VERT. SLIDE PIN

DRIVE ROLLER ASSEMBLY

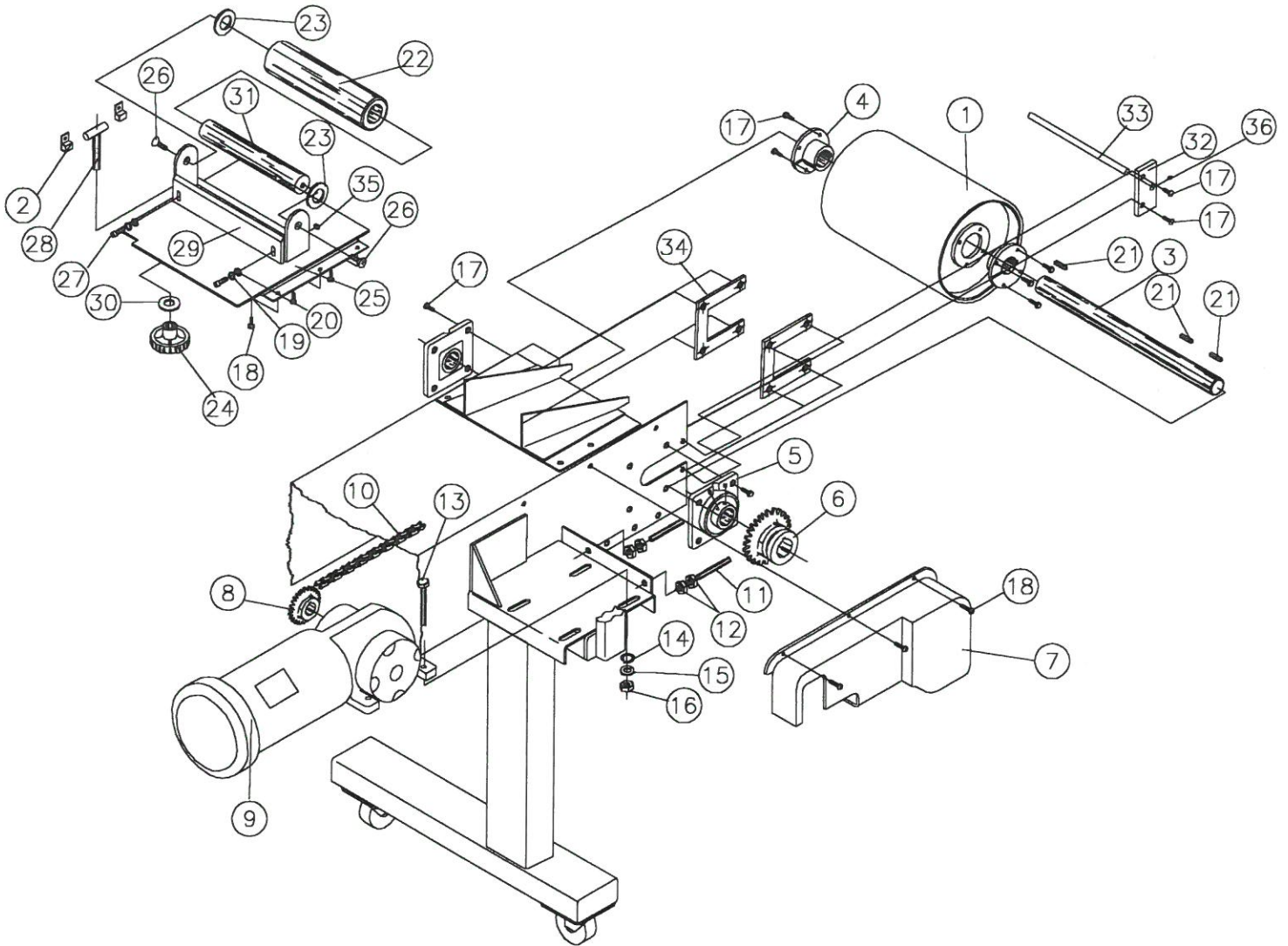

DRIVE ROLLER ASSEMBLY

ITEM	PART NO.	DESCRIPTION	NO. REQ'D
1	100DR	DRIVE PULLEY	1
2	115DR-A5	T-HANDLE MOUNT	2
3	102DR	DRIVE SHAFT	1
4	103DR	PULLEY HUB	2
5	BDP10	FLANGE BEARING	2
6	117DR	SPROCKET	1
7	BFM148002	CHAIN GUARD	1
8	106DR	MOTOR SPROCKET	1
9	SS251	GEAR MOTOR	1
10	107DR	DRIVE CHAIN	1
11	108DR	1/2 - 13 THREADED ROD	2
12	F0800NC	HEX NUT	4
13	F0606HH	3/8 - 16 BOLT	4
14	F0600LW	LOCK WASHER	4
15	F0600FW	FLAT WASHER	4
16	F0600NC	HEX NUT	4
17	F0805HH	HEX. BOLT	16
18	F0403SH	SOCKET HEAD	4
19	F0400LW	LOCK WASHER	6
20	F0400FW	FLAT WASHER	6
21	109DR	KEY 5/16"	3
22	110DR	BELT ROLLER	1
23	F1400NW	NYLON WASHER	2
24	800PHK	KNOB	1
25	115DR-A	SWING PLATE	1
26	F0402FS	FLAT SOCKET HEAD	2
27	F0403SH	SOCKET HEAD	2
28	115DR6	T-HANDLE	1
29	111DR	SCRAPER BLADE	1
30	F0800FW	FLAT WASHER	1
31	116DR	BELT ROLLER SHAFT	1
32	BFM148-005	TRIP BAR BLOCK	1
33	BFM148-017	TRIP BAR SHAFT	1
34	655CA-1A	BACKING "C" SHAPED PLATE	2
35	F0400NC	HEX. NUT	2
36	F0200SS	SET SCREW	1

ROTARY & STATIONARY TABLE ASSEMBLY

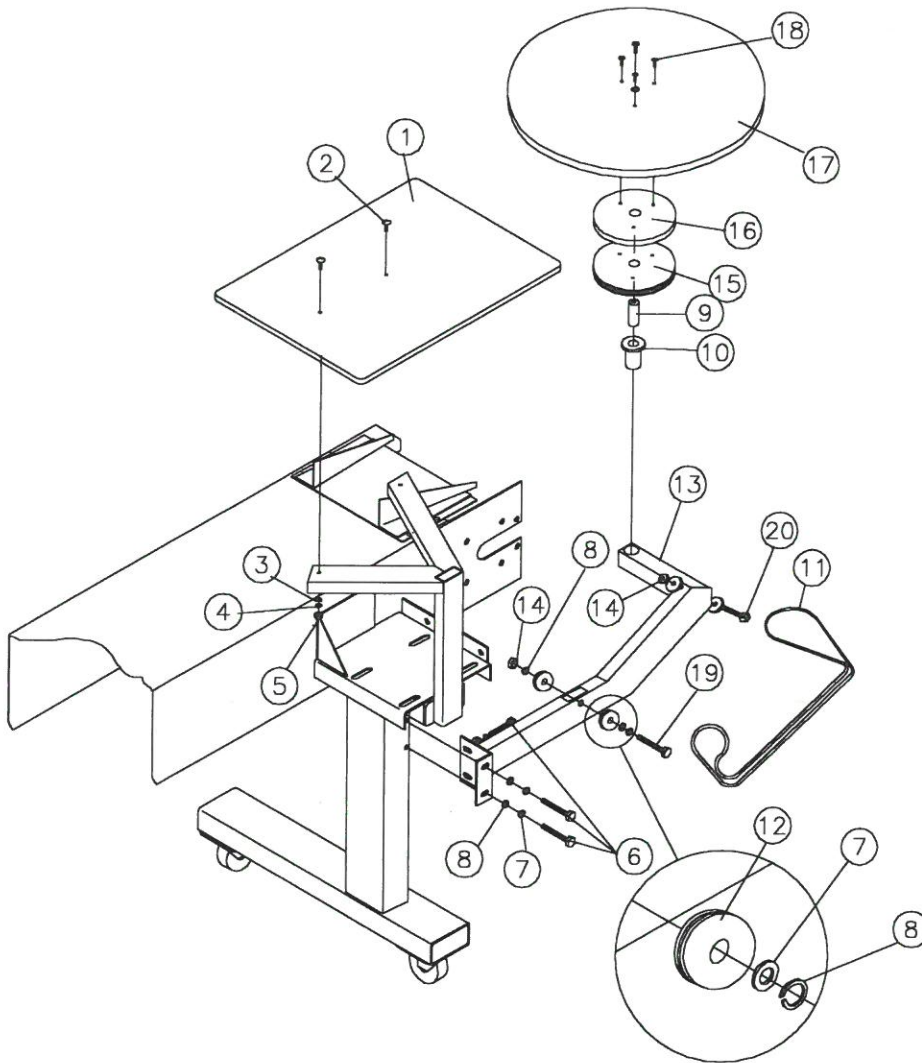

ITEM	PART NO.	DESCRIPTION	NO. REQ'D
1	BRT11A	STATIONARY TABLE	1
2	F0408CB	CARRIAGE BOLT	2
3	F0400FW	FLAT WASHER	2
4	F0400LW	LOCK WASHER	2
5	F0400NC	HEX NUT	2
6	F0604HH	HEX BOLT	4
7	F0600LW	LOCK WASHER	5
8	F0600FW	FLAT WASHER	5
9	BFM148007	TABLE SHAFT	1
10	BFM148016	TABLE BUSHING	1
11	BFM148021	ORANGE BELT (DRIVE)	1
12	BFM148072	ROLLERS FOR TABLE	4
13	BFM148010	TABLE EXTENTION ARM	1
14	F0600NC	HEX. NUT	2
15	BFM148015	TABLE FLANGE PULLEY	4
16	BFM148014	TABLE SPACER	1
17	BFM148019	24" ROTARY TABLE	1
18	F0405FSH	FLAT SOCKET HEAD	4
19	F0610HH	HEX HEAD	1
20	F0614HH	HEX HEAD	1

CABINET WELDMENT

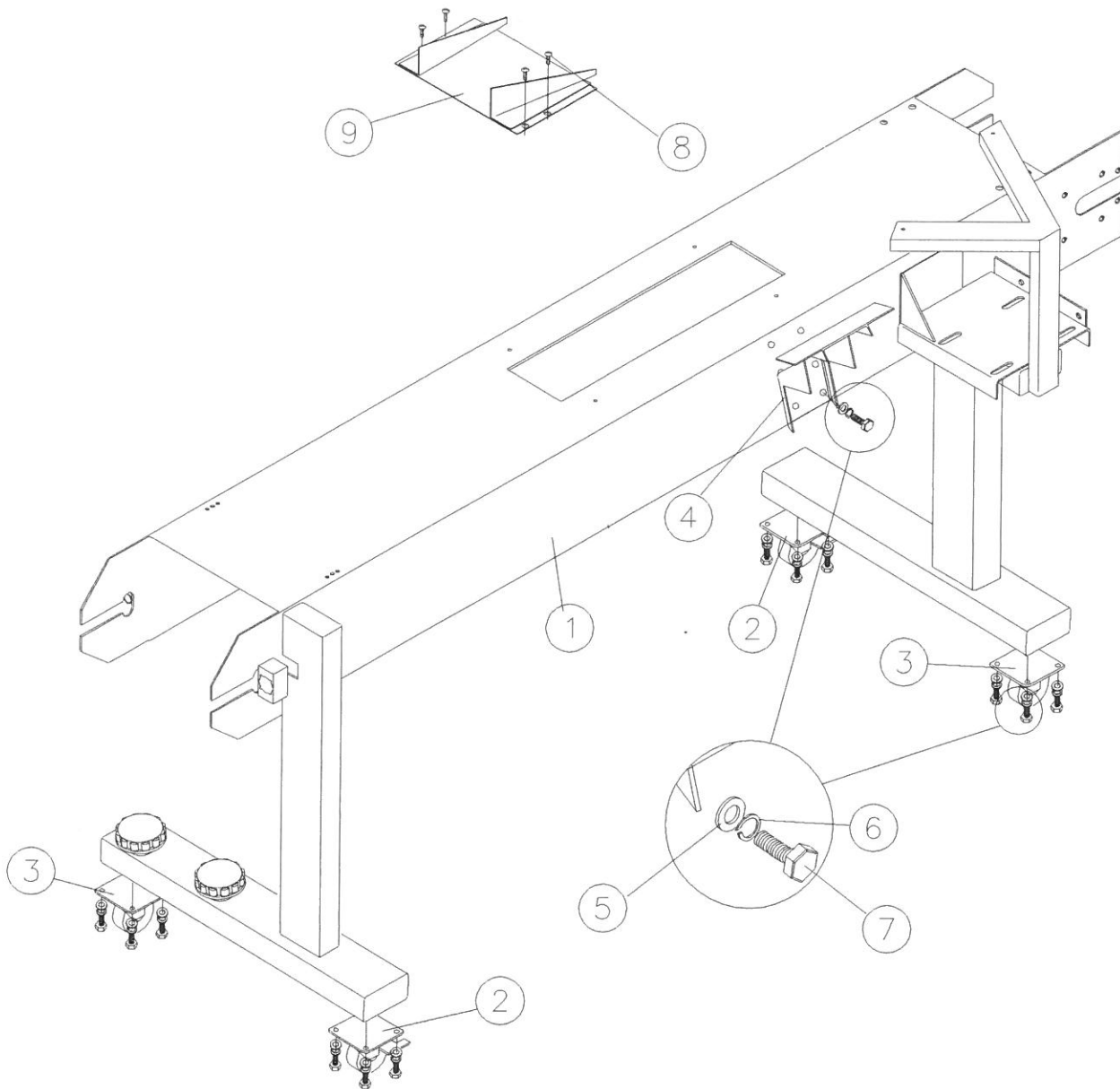

ITEM	PART NO.	DESCRIPTION	NO. REQ'D
1	655CAS	MAIN CABINET WELDMENT	1
2	621CA1	SWIVEL CASTER	2
3	621CA2	SWIVEL CASTER (LOCKING)	2
4	BFM148001	CONTROL BOX SUPPORT	1
5	F0400FW	FLAT WASHER	20
6	F0400LW	LOCK WASHER	20
7	F0404HH	HEX HEAD	20
8	F9702RH	#8 - 32 SCREW	4
9	659CA	BELT GUIDE	1

ELECTRICAL LAYOUT

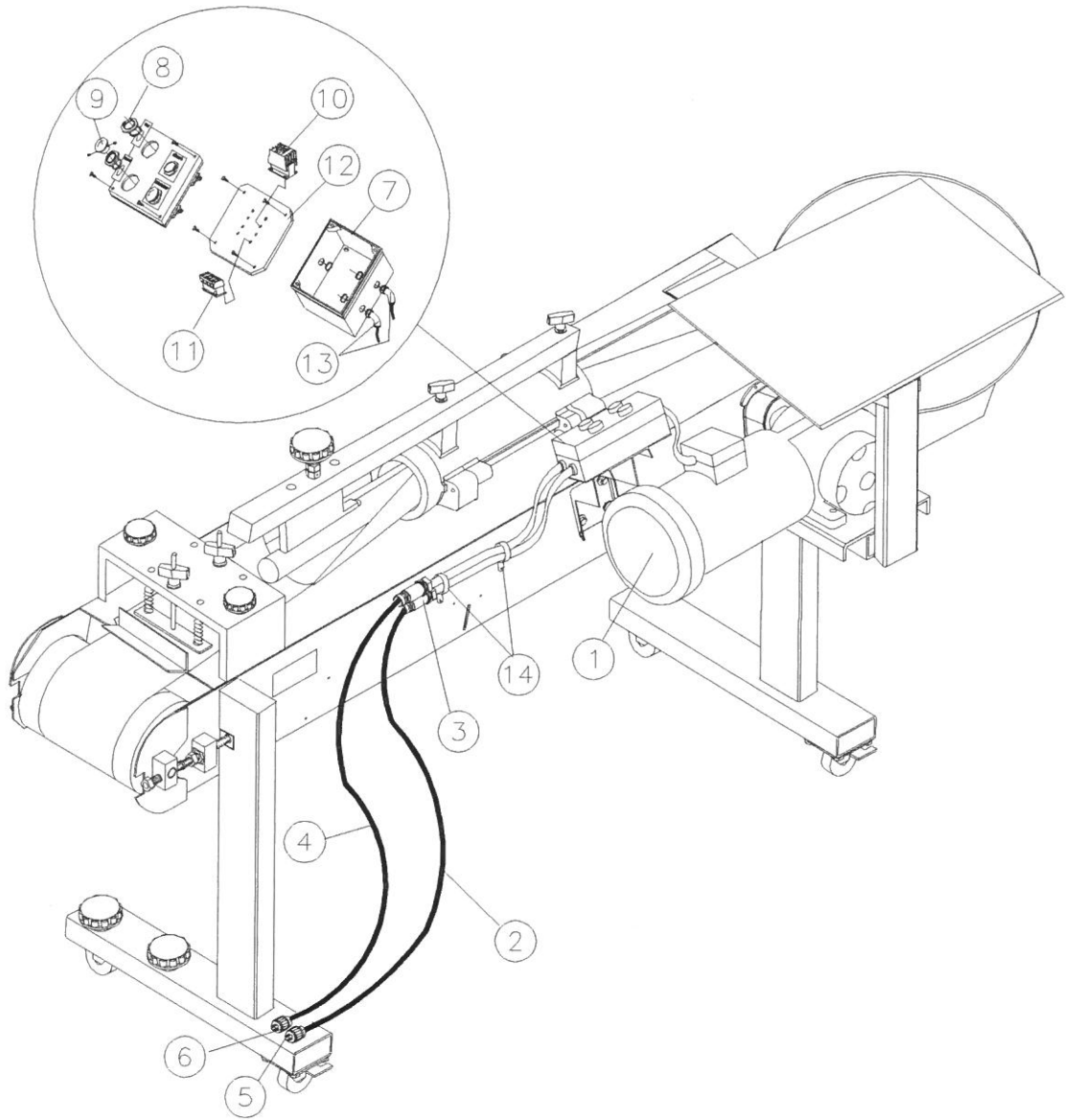

ITEM	PART NO.	DESCRIPTION	NO. REQ'D
1	SS251	DRIVE MOTOR	1
2	S5228	32" SEALTIGHT 8'-16/4 CONTROL CORD	8'
3	SS348	CORD GRIP ASSEMBLY	2
4	S5228	37" SEALTIGHT 9" 16/4 LINE CORD	93"
5	SS159	PLUG	1
6	SS157	PLUG	1
7	SS279	ELECTRICAL ENCLOSURE	1
8	SS184	START BUTTON	2
9	SS185	STOP BUTTON	2
10	SS236	MOTOR CONTACTOR	1
11	SS206	OVERLOAD 208/220 AMP.	1
12	400034	ELECTRICAL ENCLOSURE	1
13	SS284	1/2" 45 DEG. ELBOW	2
14	SS284	JIFFY CLIP	2

(* NOTE: OPTOINAL WITH ROTARY KNIFE DIVIDER/FORMER: MODEL RK2200...

ELECTRICAL DIAGRAM

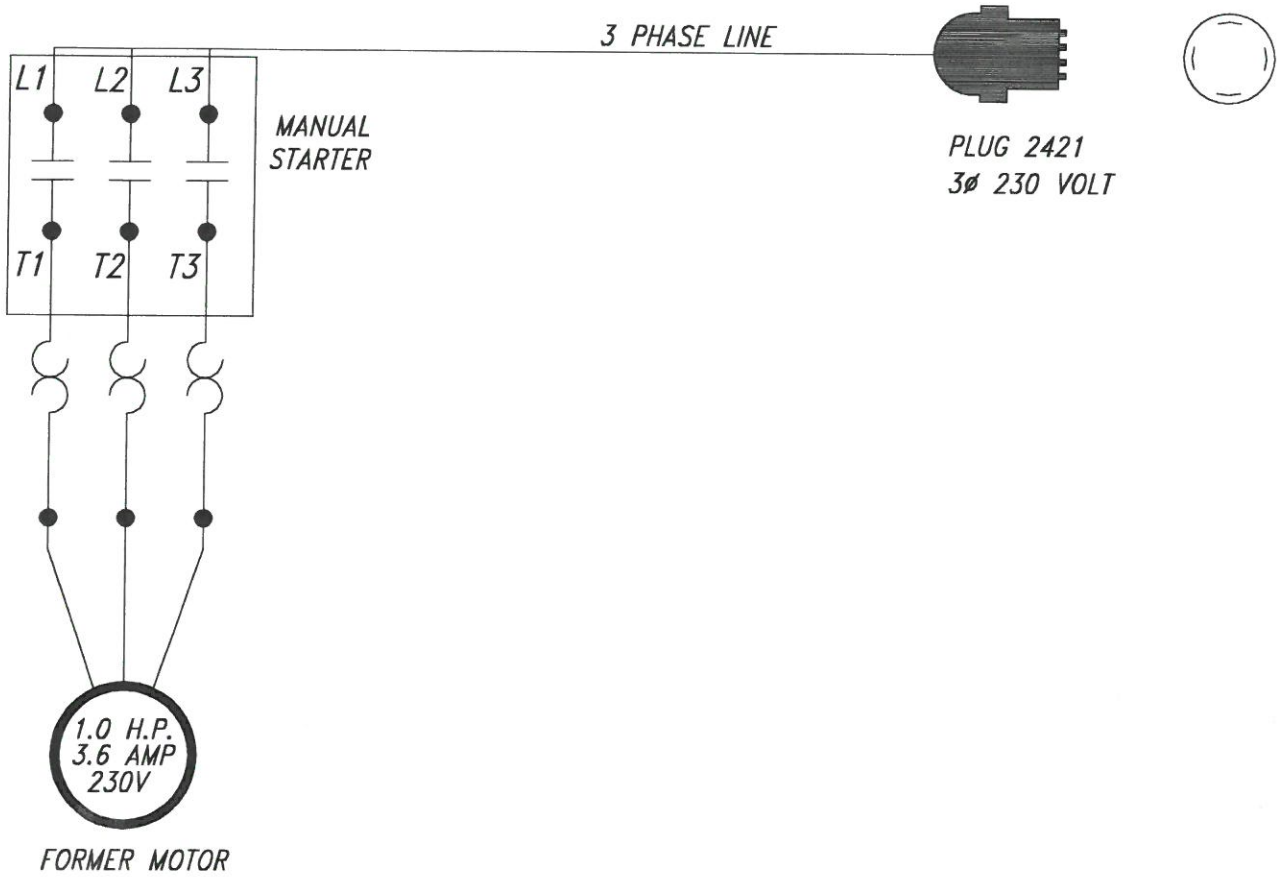

DETAIL "A"

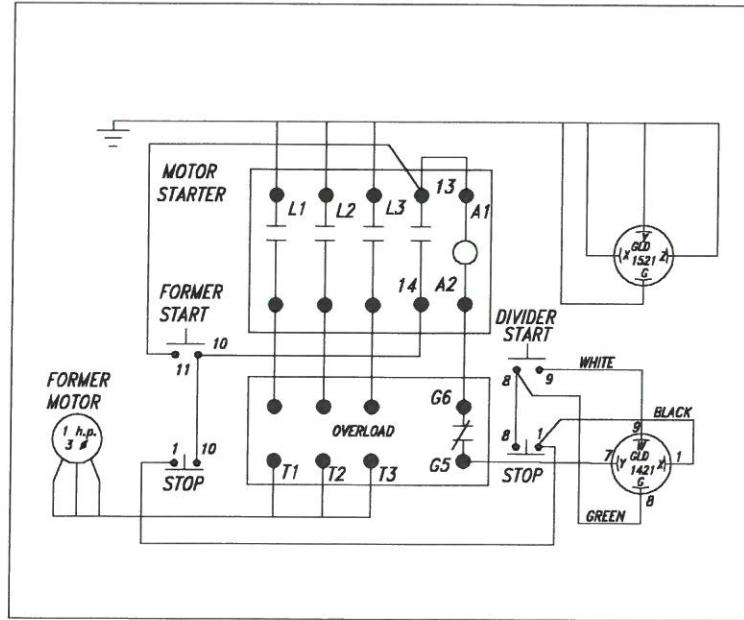

NOTE:
 DETAIL "A" OPTIONAL WITH ROTARY
 KNIFE DIVIDER / BAGEL FORMER
 MODEL: RK2200

ORDERING REPLACEMENT PARTS

IMPORTANT:

ONLY USE FACTORY SUPPLIED REPLACEMENT PARTS TO MAINTAIN MACHINE SAFETY, PERFORMANCE AND SANITARY CONDITIONS.

USE OF NON-APPROVED PARTS MAY VOID MANUFACTURES WARRANTY.

TO ORDER REPLACEMENT PARTS ALWAYS:

- 1) CHECK THE MACHINE TOP IDENTIFY MISSING, DAMAGED OR NON-FUNCTIONAL PARTS INCLUDING GUARDS, WARNING LABELS AND INSTRUCTIONS.
- 2) COMPARE THE LIST WITH THE PARTS DIAGRAMS SUPPLIED.
- 3) RECORD THE COMPLETE MODEL AND SERIAL NUMBER OF THE UNIT.
- 4) CALL A.M. MANUFACTURING (800) 342-6744 AND PROVIDE ALL INFORMATION NOTED ABOVE TO EXPEDITE ORDER PROCESSING AND HELP REDUCE SHIPPING COST.
- 5) PROVIDE COMPLETE DETAILS FOR (SHIP TO) AND (BILL TO) INFORMATION. TO ASSIST PROMPT DELIVERY, SPECIFY TYPE OF CARRIER PREFERRED IN SHIPMENT.
- 6) ALL MAJOR CREDIT CARDS ACCEPTED.

