

Tor-O-Matic 32x32 Tortilla Press

Specifications

* Length	12' 7" / 378cm
* Width	52" / 130cm
* Height	76" / 190cm
* Production Rate (depending on size)	600 - 4800 per hour
* Press Force	Fully adjustable
* Press Time	Fully adjustable
* Temperature Range	0 [∞] - 500 [∞] F
* Press Belt Speed	Fully adjustable
* Discharge Conveyor Speed	Fully adjustable
* Hydraulic Oil Capacity	20 gal / 76 liter
* Shipping Weight	2800 lb. / 1260kg

Features

- * Two speed, height adjustable discharge conveyor system for smooth product transfer
- * Greater formula flexibility # Made in the U.S.A.
- * Approved by the United States Department of Agriculture
- * No flour dusting necessary
- * Fully adjustable heat, pressure and dwell time
- * Fully automatic variable speed belt indexing
- * All stainless steel cabinet
- * Simplified electrical system
- * One year limited warranty on parts
- * On board hydraulic system
- * Can produce a variety of tortilla shell sizes
- * Solid state time and temperature controls
- * Mounted on casters

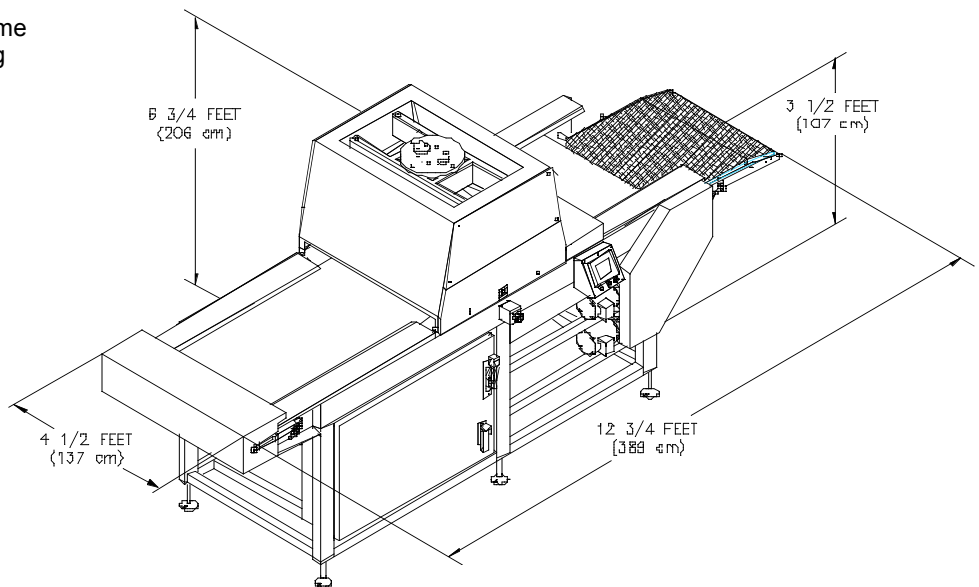

Electrical Requirements

- * 240 volt / 3 phase / 60 Hz / 150 amps
- * 480 volt / 3 phase / 60Hz / 70 amps
- * 110 volt single phase control circuit
- * Other Voltages Available



14151 Irving Avenue Dolton, IL. 60419
 Phone: (708) 841-0959 or (800) 342-6744 Fax: (708) 841-0975

www.ammfg.com