

# Tor-O-Matic 24x24 Tortilla Press

## Specifications

* Length	120" / 305cm
* Width	48" / 122cm
* Height	78" / 198cm
* Production Rate (depending on size)	400 dozen per hour
* Press Force	Fully adjustable
* Press Time	Fully adjustable
* Temperature Range # Press Belt Speed	Ambient - 500 F
* Discharge Conveyor Speed	Fully adjustable
* Hydraulic Oil Capacity	Fully adjustable 20 gal / 76 liter
* Shipping Weight	1800 lbs. / 810kg

## Features

- \* Two speed, height adjustable discharge conveyor system for smooth product transfer
- \* Greater formula flexibility # Made in the U.S.A.
- \* Approved by the United States Department of Agriculture
- \* No flour dusting necessary
- \* Fully adjustable heat, pressure and dwell time
- \* Fully automatic variable speed belt indexing
- \* Simplified electrical system
- \* One year limited warranty on parts
- \* On board hydraulic system
- \* Can produce a variety of tortilla shell sizes
- \* Solid state time and temperature controls

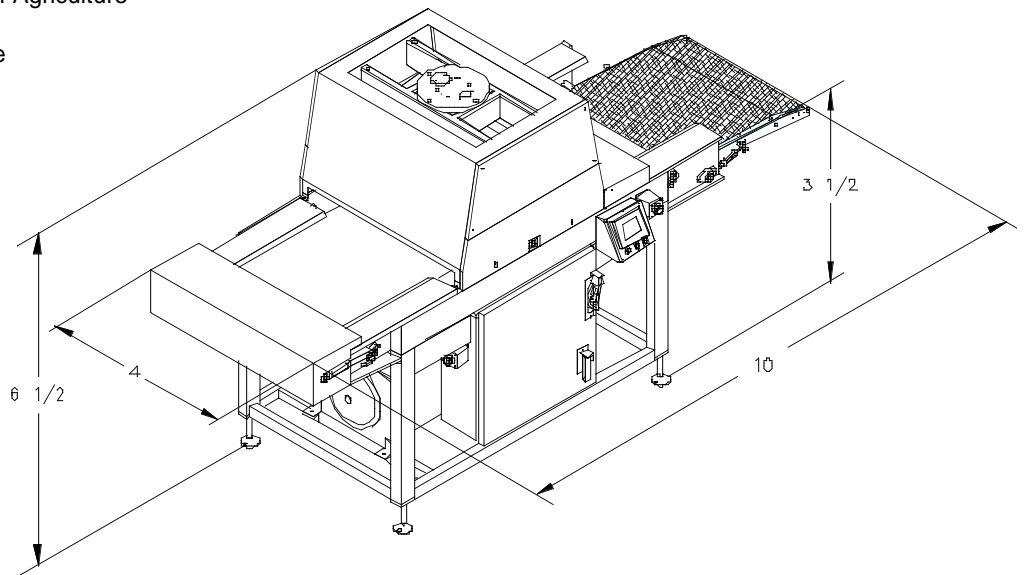

## Electrical Requirements

- \* 208-230 volt / 3 phase / 60 Hz / 150 amps
- \* 110 volt single phase control circuit
- \* Other Voltages Available



14151 Irving Avenue Dolton, IL. 60419  
 Phone: (708) 841-0959 or (800) 342-6744 Fax: (708) 841-0975