

## Specifications

* Length	82" / 205cm
* Width	24" / 65cm
* Height	58" / 145cm
* Production Rate	2,000 pieces per hour
* Hopper Capacity	100 lbs. / 45 kg
* Shipping Weight	1,000 lbs. / 454 kg
* Divider Motor HP	2 HP
* Conveyor Motor HP	3/4 HP

## Features

- \* Precise dividing form 1 to 3 ounces
- \* 6,000 to 10,000 pieces per hour (depending on size)
- \* All stainless steel cabinet
- \* 100 lbs. hopper capacity
- \* Easily disassembled for cleaning
- \* One man operation
- \* Variable speed optional
- \* 6" stainless steel pressure plate
- \* Improved safety features
- \* Made in U.S.A.
- \* Parts and Service readily available
- \* Quick and simple weight change adjustments
- \* Easily movable on locking swivel casters
- \* One year limited Warranty

## Multi Dough Divider

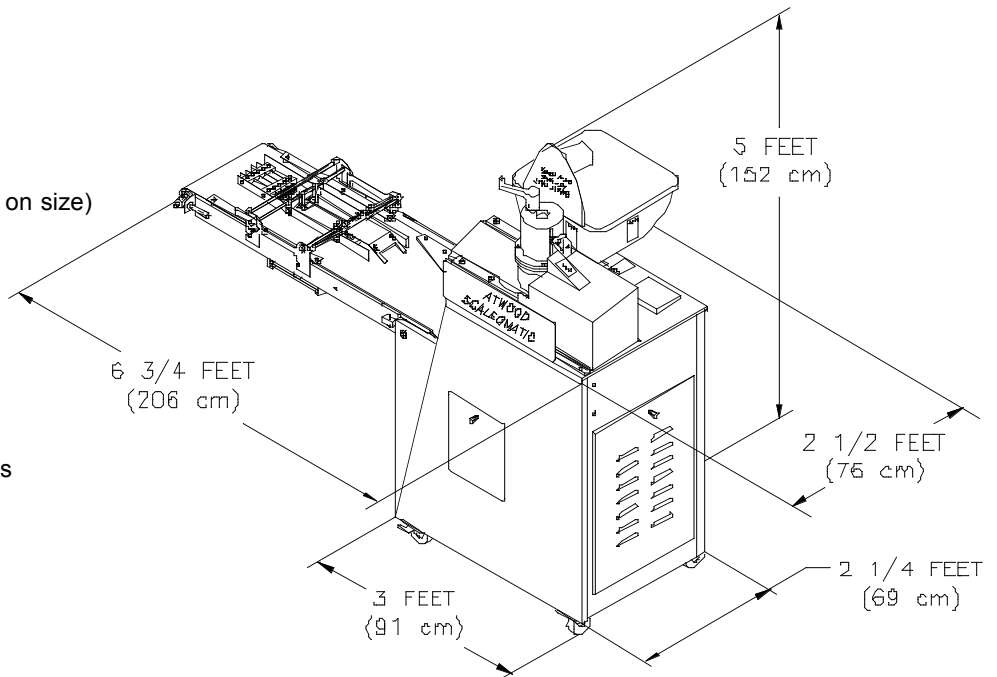

## Optional Equipment

- \* Extended Hopper (140 lbs. capacity)
- \* Computerized Variable Speed
- \* External Oil Tank
- \* USDA/FDA approved conveyor belt
- \* 3 Cutter (2 to 3 ounce) / (56 to 84 grams)
- \* 4 Cutter (1 1/4 to 2 ounce) / (35 to 56 grams)
- \* 5 Cutter (1/4 to 3/4 ounce) / (7 to 21 grams)

## Electrical Requirements

- \* 208 or 220 volt / 20 amps
- \* Single or 3 phase 60 Hz.
- \* For other options or custom voltages, please contact our factory.



14151 Irving Avenue Dolton, IL. 60419  
 Phone: (708) 841-0959 or (800) 342-6744 Fax: (708) 841-0975