



AM Manufacturing

Scale-O-Matic S301

Specifications

- Length 57"
- Width 58"
- Height 62"
- Production Rate 2000 pieces per hour
- Scaling Range 1 to 32 ounces
- Shipping Weight 1400 lbs.

Dough Divider & Rounder

Features

- Easy one person operation
- Divider can be ordered separately to compliment an existing model R900 rounder
- Production rate: Up to 2000 pieces per hour (depending on size)
- Portable. Lockable, swivel casters on both machines
- Adjustable height take off conveyor; folds up for storage
- No need to adjust rounder when changing weight and sizes
- Accurate weight change with the turn of a crank
- Stainless steel construction
- No mess, no flour dust
- Easy-to-clean. No bending required
- Hopper capacity: 80 lbs.
- Divider and rounder can be used separately
- Precise dividing from one to 32 ounces
- Self-lubricating
- Hopper capacity: 80 lbs.

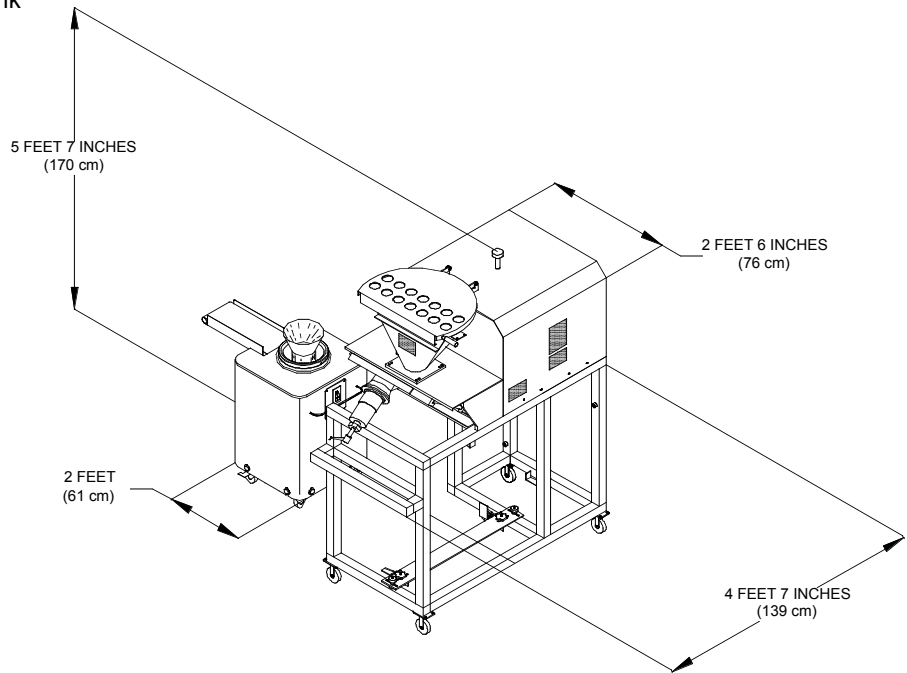

Optional Equipment

- Extended hopper capacity (125 lbs.)
- Extended outfeed conveyor for rounder

Electrical Requirements

- 208-240 volt/ three phase (divider)
- 120 volt / single phase (rounder)
- Special overseas voltages are available



14151 Irving Avenue • Dolton, IL 60419
 Phone: 708-841-0959 or 800-342-6744 Fax: 708-841-0975
www.ammfg.com