

# Scale-O-Matic S300

## Specifications

* Length	64" / 163cm
* Width	24" / 61cm
* Height	58" / 147cm
* Production Rate	2,000 pieces per hour
* Scaling range	AMS2 Measuring Cup--2 to 4 oz. / 56 to 227g AMS3 Measuring Cup--4 to 10 oz. / 112 to 280g AMS5 Measuring Cup--10 to 32 oz. / 280 to 896g
* Shipping Weight	1,000 lbs. / 455 kg

## Dough Divider & Rounder

## Features

- \* Precise dividing from 2 to 32 oz. at a rate of 2,000 pieces per hour
- \* Accurate weight change with the turn of a crank
- \* One man operation
- \* All stainless steel cabinet
- \* Easily movable on locking swivel casters
- \* Rounder easily disassembled for cleaning, no tools required
- \* 100 lb. hopper capacity
- \* Separate controls for divider and rounder
- \* Rounder can be used separately
- \* Adjustable height take off conveyor; folds up for storage
- \* No need to adjust rounder when changing size
- \* Automatic oiling system on divider
- \* Divider easily disassembled for cleaning
- \* 2HP divider motor
- \* 1 HP rounder motor
- \* Made in the U.S.A.
- \* Parts and Service are readily available
- \* Full one year limited warranty

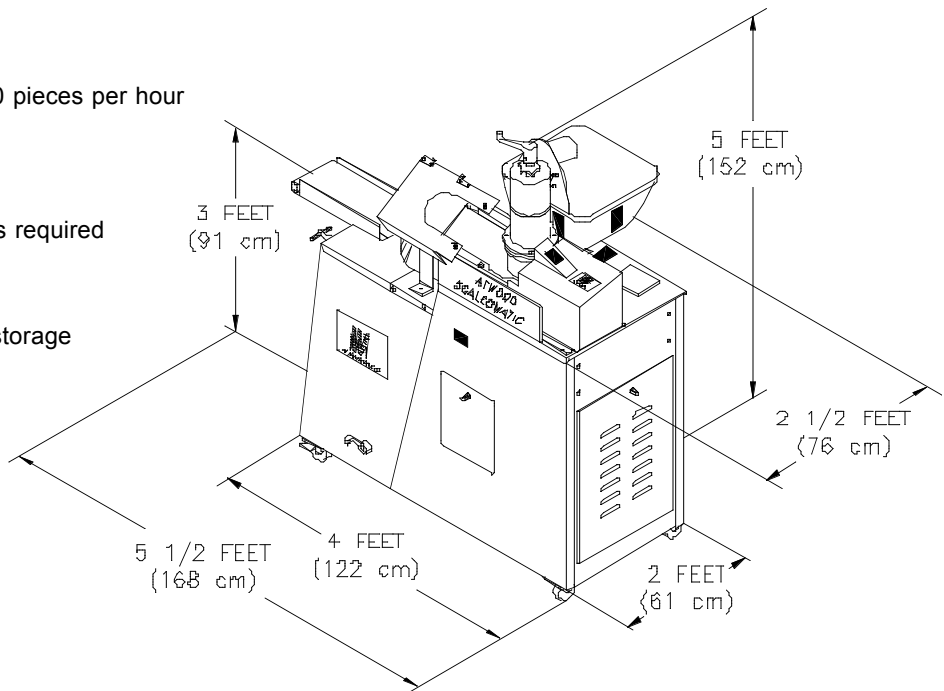

## Optional Equipment

- \* Extended Hopper (140 lbs. capacity)
- \* Computerized Variable Speed
- \* External Oil Tank
- \* Extended Outfeed Conveyor

## Electrical Requirements

- \* 208 or 220 volt / 20 amps
- \* Single or 3 phase 60 Hz.
- \* For other options or custom voltages, please contact our factory.
- \* UL listing applies to control panel only
- \* ETL listing applies to entire machine



14151 Irving Avenue Dolton, IL. 60419  
 Phone: (708) 841-0959 or (800) 342-6744 Fax: (708) 841-0975

www.ammfg.com