



AM Manufacturing

Scale-O-Matic S250

Automatic Dough Divider

Specifications

- * Length 36" / 90cm
- * Width 24" / 60cm
- * Height 58" / 145cm
- * Scaling Range
 - AMS2 Measuring Cup--2 to 4 oz. / 56 to 227g
 - AMS3 Measuring Cup--4 to 10 oz. / 112 to 280g
 - AMS5 Measuring Cup--10 to 32 oz. / 280 to 896g
- * Production Rate 2,000 pieces per hour
- * Hopper Capacity 100 lbs. / 45 kg
- * Shipping Weight 500lbs. / 227 kg

Features

- * Compact unit (requires only 4 1/2 square feet)
- * One man operation
- * Made in the U.S.A.
- * Stainless steel cabinet
- * Parts and Service readily available
- * Cabinet mounted baking pan rack
- * Precise dividing from 2 to 32 ounces at a rate of 2,000 pieces per hour
- * 100 lbs. hopper capacity
- * Easily movable on locking swivel casters
- * Full one year limited warranty
- * Automatic oiling system
- * Easily disassembled for cleaning
- * 2 HP divider motor

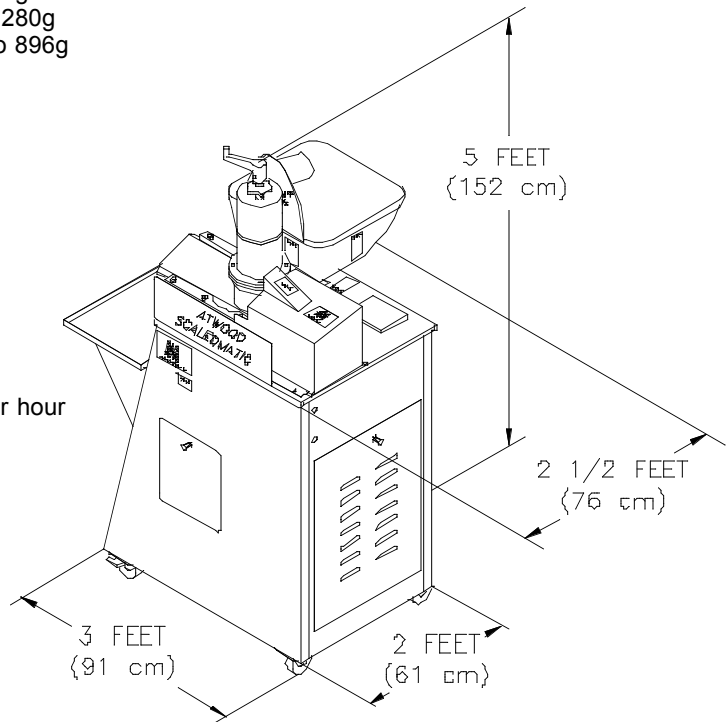

Optional Equipment

- * Extended Hopper (140 lbs. capacity)
- * Computerized Variable Speed # External Oil Tank

Electrical Requirements

- * 208 or 220 volt / 20 amps
- * Single or 3 phase / 60Hz
- * For other options or custom voltages, please contact our factory.



14151 Irving Avenue Dolton, IL. 60419
 Phone: (708) 841-0959 or (800) 342-6744 Fax: (708) 841-0975

www.ammfg.com