

Specifications

* Table Diameter	35 1/2" / 90cm
* Machine Width	24" / 61cm
* Overall Height	42 1/2" / 108cm
* Height Under Table	36 1/4" / 92cm
* Production Range	1 Oz. to 2 1/2lbs / 28g to 1.13kg
* Production Rate	Up to 7,200 pieces per hour (depending on size)
* Shipping Weight	350 lbs. / 160kg

Dough Rounder With Table

Features

- * Stainless steel cabinet construction
- * Easy clean-up; no tools required
- * No size adjustments necessary
- * Up to 7,200 pieces per hour (depending on size)
- * One person operation
- * Mounted on casters for easy mobility
- * Made in the U.S.A.
- * Handles dough sizes from 1 Oz. to 2 1/2 lbs.
- * Produces a very tight round dough ball
- * Compact and easy to operate

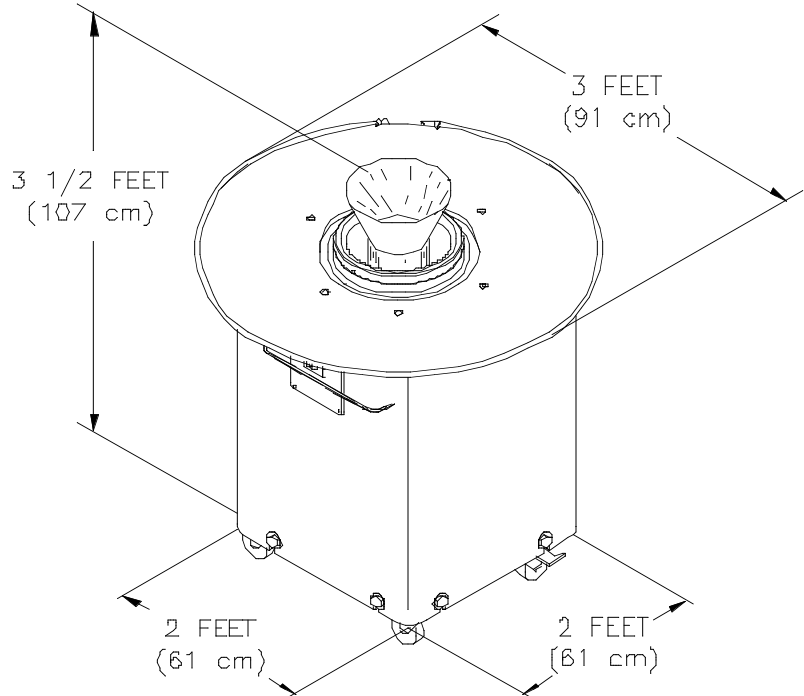

Optional Equipment

- * 3 phase Electrical System
- * 2 H.P. Rounder Motor

Electrical Requirements

- * 115 volt Single phase 15 amps
- * Custom electrical available



14151 Irving Avenue Dolton, IL. 60419
Phone: (708) 841-0959 or (800) 342-6744 Fax: (708) 841-0975