

Round O Matic R900RT

Specifications

| | |
|--------------------------|---|
| * Length | 24" / 61cm |
| * Machine Width | 19" / 48cm |
| * Overall Machine Height | 44" / 112cm |
| * Production Range | 1 oz. to 2 1/2 lbs. / 28g to 1.13kg |
| * Production Rate | Up to 7,200 pieces per hour (depending on size) |
| * Shipping Weight | 350 lbs. / 160 kg. |

Features

- * Convenient one person operation
- * Up to 7,200 pieces per hour (depending on product size)
- * Handles dough sizes from 1 Oz. to 2 1/2 lbs
- * No adjustments necessary for this great size range
- * Stainless steel cabinet an Teflon coating insures easy clean up and maintenance
- * Made in the U.S.A.
- * Produces very round and tight dough balls
- * Smooth rolling, locking casters allow high mobility to any work area
- * Parts requiring clean up are easily removed without tools
- * Normal maintenance limited to periodic inspection and oiling of drive components
- * 1 5/8" table leg stretchers insure stability
- * Stud welded hat sections reinforce and maintain level working surface
- * Space saving and compact
- * Top is furnished with 1 5/8" sanitary rolled rim edges on three sides with rounded bull-nose corners and a 5" splash with a 1" return on the rear side.

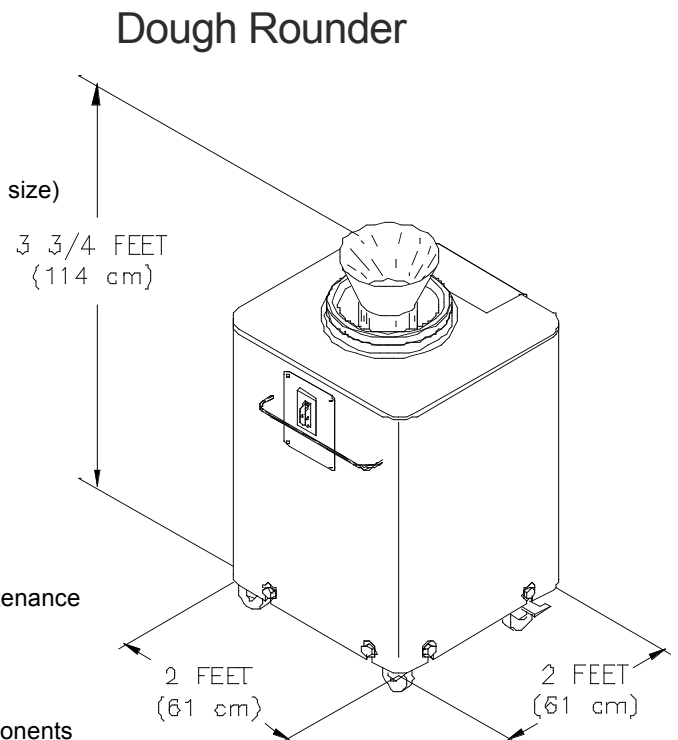

Optional Equipment

- * 3 phase Electrical System
- * 2 H.P. Rounder Motor

Electrical Requirements

- * 115 volt Single phase 15 amps
- * Custom electrical available



14151 Irving Avenue Dolton, IL. 60419
 Phone: (708) 841-0959 or (800) 342-6744 Fax: (708) 841-0975

www.ammfg.com